

## SIZING OF A BATTERY ENERGY STORAGE SYSTEM TO MINIMIZE UNDERFREQUENCY LOAD SHEDDING IN ISLAND POWER SYSTEMS

Lukas SIGRIST

Comillas Pontifical University – Spain  
[lukas.sigrist@iit.comillas.edu](mailto:lukas.sigrist@iit.comillas.edu)

Luis ROUCO

Comillas Pontifical University – Spain  
[luis.rouco@iit.comillas.edu](mailto:luis.rouco@iit.comillas.edu)

Clara JIMENEZ

Comillas Pontifical University – Spain  
[clara.jimenez@iit.comillas.edu](mailto:clara.jimenez@iit.comillas.edu)

### ABSTRACT

*This paper presents a method to size battery energy storage systems (BESSs) to minimize underfrequency load shedding in island power systems. The proposed method depends on a simplified representation of the power system, where generating units are represented by first-order systems. An analytical expression is derived to estimate the BESS size. The proposed method has been applied to two Spanish isolated power systems. Dynamic simulations with PSS/E software package confirm the proposed method to size BESS. BESS with a capacity around 6% to 9% of the installed generation capacity are needed to avoid load shedding.*

### INTRODUCTION

A major problem of islanded operation is frequency stability [1]. Frequency stability denotes the ability of generating units to maintain frequency within an acceptable range after a disturbance causing an active power imbalance. Frequency dynamics depend on the system's inertia and the generating units turbine-governor systems. Typically, large active power imbalances cause load shedding since frequency drops quickly and turbine-governor systems of generating units cannot increase power generation sufficiently fast.

Battery energy storage systems (BESSs) can effectively contribute to enhance frequency stability of isolated power systems by injecting active power after a disturbance quickly and thus avoiding or reducing load shedding [2]. The impact of an ultracapacitor (UC) on frequency stability of Guadeloupe Island has been analyzed for two scenarios of different wind and solar PV penetration levels [3]. In [4], a UC has been used among others to provide frequency control for an isolated power system with renewable energy sources by means of a proportional-plus-integral (PI) controller. BESS can emulate inertia and provide droop control. The values of emulated inertia and droop influence the effectiveness. Adaptive droop with inertia emulation has been proposed in [5]. Frequency control through a combined solution of UC and BESS has been proposed in [6], where the UC emulates inertia and the BESS provides droop control.

This paper presents a method to estimate the BESS size to avoid load shedding. The method is based on an analytical expression to estimate the BESS's power capacity. The analytical expression actually determines the critical power imbalance, which leads to an acceptable frequency deviation without activating underfrequency load shedding (e.g., 49 Hz). In case of an imbalance larger than the critical one, the BESSs must provide the difference between them. This idea is similar to the one presented in

[7] to determine the amount of load to be shed. The analytical expression and thus the size of the BESS depend on the power imbalance as well as on the dynamics of the turbine-governor systems and rotors.

The paper is organized as follows: first, the BESS sizing method is outlined. Then, the BESS model for dynamic simulations in PSS/E is presented. The proposed power capacity estimation is finally validated by means of detailed dynamic simulations for two Spanish isolated power systems under real operating conditions. The BESS emulates inertia and provides droop control.

### BESS SIZING METHOD

This section presents the method to size. The impact of the BESS on frequency stability depends on its power and energy sizing.

The sizing of the BESS depends on the response speed of both the power system and the BESS. The response of the BESS is much faster than the one of the generating units and in particular, of their turbine-governor systems. For a large disturbance and depending on the settings of the control parameters, the BESS nearly instantaneously reaches its maximum power output (within some hundreds of milliseconds).

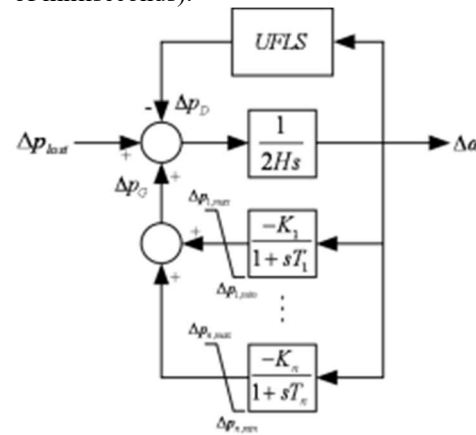

Figure 1: Simplified power system model.

The sizing method is based on a simplified power system model as shown in Figure 1. The model of the power system presented here is widely used for the analysis of frequency stability since it is able to reflect short-term frequency dynamics of small isolated power systems [7]. It is assumed that generating units can be represented by a first-order system of gain  $K_i$  and time constant  $T_i$ , and that frequency is uniform, leading to an equivalent inertia  $H$ . By assuming that power is approximately equal to torque

in pu, the model of Fig. 1 can be also formulated as:

$$2H\Delta\dot{\omega} = \Delta p_G - D\Delta\omega - \Delta p_D - p_{lost}$$

$$\Delta\dot{p}_i = -\frac{1}{T_i}(\Delta p_i + k_i\Delta\omega) \quad (1)$$

$$\Delta p_G = \sum_{i=1}^n \min(\max(\Delta p_i, \Delta p_{i,min}), \Delta p_{i,max})$$

During the first instants after the disturbance, by omitting the load-damping factor and by neglecting the limitations, the response of the power system can be approximated as follows:

$$2H\Delta\dot{\omega} = \sum_{i=1}^n \Delta p_i - \Delta p_D - p_{lost}$$

$$\Delta\dot{p}_i = -\frac{k_i}{T_i}\Delta\omega \quad (2)$$

Differentiating equation (2) yields to:

$$2H\Delta\ddot{\omega} = -\sum_{i=1}^n \frac{k_i}{T_i}\Delta\omega - \Delta\dot{p}_D - \dot{p}_{lost} \quad (3)$$

and by applying the Laplace transform, one obtains:

$$2Hs^2\Delta\omega(s) + \sum_{i=1}^n \frac{k_i}{T_i}\Delta\omega(s) = -s\Delta p_D(s) - sp_{lost}(s) \quad (4)$$

Modeling the disturbance  $p_{lost}(s)$  by a step of size  $p_{lost}$ , omitting any demand response (e.g., load shedding), and performing the inverse Laplace transform yields to the time domain response  $\Delta\omega(t)$ :

$$\Delta\omega(t) = -\frac{p_{lost}}{\sqrt{2H\sum_{i=1}^n \frac{k_i}{T_i}}} \sin\left(\sqrt{\frac{1}{2H\sum_{i=1}^n \frac{k_i}{T_i}} \cdot t}\right) \quad (5)$$

The minimum frequency deviation is given by:

$$\Delta\omega_{min} = -\frac{p_{lost}}{\sqrt{2H\sum_{i=1}^n \frac{k_i}{T_i}}} \quad (6)$$

Equation (6) allows estimating the critical power loss  $p_{lost,c}$  for which frequency will just reach the minimum allowable frequency:

$$p_{lost,c} = -\Delta\omega_{min} \sqrt{2H\sum_{i=1}^n \frac{k_i}{T_i}} \quad (7)$$

In case of a disturbance larger than the critical power loss, the BES should provide the difference between the disturbance and the critical loss. If the largest possible disturbance ( $p_{lost,max}$ ) was known, the power capacity of the BESS could be sized as follows:

$$p_{BESS} = p_{lost,max} - p_{lost,c} \quad (8)$$

Equation (10) assumes that the BESS nearly instantaneously reaches its maximum power output, which is true for large disturbances and depends on the control parameter settings.

## MODEL OF THE BESS FOR DYNAMIC SIMULATIONS IN PSS/E

In this section, the model of the BESS for dynamic simulations in PSS/E is presented. The model includes

both frequency and voltage control, a simplified representation of the power electronic converters and its control. Since this paper focuses on frequency stability and since frequency and voltage control can be made almost independent by means of an appropriate d-q axes representation, only the model related to frequency control will be detailed.

Figure 2 shows the model of the BESS used for dynamic simulations in PSS/E. The BESS not only participates in primary frequency control but it also emulates inertia.  $R$  is the droop control gain and  $H$  is the emulated inertia. A lower and upper limit as well as a ramp limiter are applied to the power set point resulting from the frequency control. Converters and the inner current-control loops are represented by a first-order model with time constants  $T_d$  and  $T_q$ . Current limiters are included as well, limiting current module and prioritizing active or reactive power injection if needed.

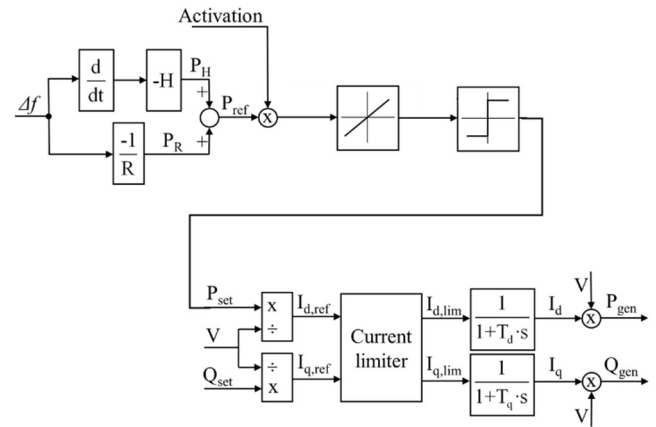

Figure 2: Model of the BESS for dynamic simulations in PSS/E.

For static and dynamic simulations, BESS has been implemented as a controllable load.

## APPLICATION TO SPANISH ISOLATED POWER SYSTEMS

The proposed sizing method for BESS is applied to two Spanish isolated power systems. For each power system, two generation dispatch scenarios will be considered to determine the size of the BESS. The BESS will be sized such that frequency does not fall below 49 Hz, the threshold where underfrequency load shedding starts. The appendix contains information on the two scenarios of each systems as well as on the parameters of the simplified power system model.

### System A

Table 3 in the appendix shows the two generation dispatch of power system A. For both scenarios, the outage of generating unit G6 represents the most critical incident, leading to a minimum frequency far below 49 Hz. By applying equation (7) and by taking into account that only two units remain online after the outage of G6, the critical power loss of G6 amounts to 2.8 MW in order the

frequency not to fall below 49 Hz. BESS size can then be determined according to the equation (8). Table 1 shows the estimated BESS sizes of power system A. It results that a BESS of at least 12.2 MW is needed. This corresponds to about 6% of the installed generation capacity.

BESS (MW)	
1	12.2
2	7.2

Table 1: BESS power capacity for the two considered scenarios.

In order to validate the estimated BESS size, the outage of each generating unit for both generation dispatch scenarios has been simulated. BESS sizes of 0, 8, 10, 12, and 14 MW have been considered. The BESS's droop is set to 1.33% and the emulated inertia is equal to 20 s, yielding to an acceptably fast BESS response.

Figure 3 shows the response of the system to the outage of G6 in scenario 1 in terms of frequency, mechanical power, and demand with BESS. Frequency falls below 49 Hz, leading to load shedding actions, reflected in the demand. Figure 4 shows the response of the system to the same outage with 14 MW BESS. It can be seen that frequency does not fall below 49 Hz. Demand is lowered since the BESS has been modelled as a controllable load in PSS/E (BESS injects additional power, reducing demand).

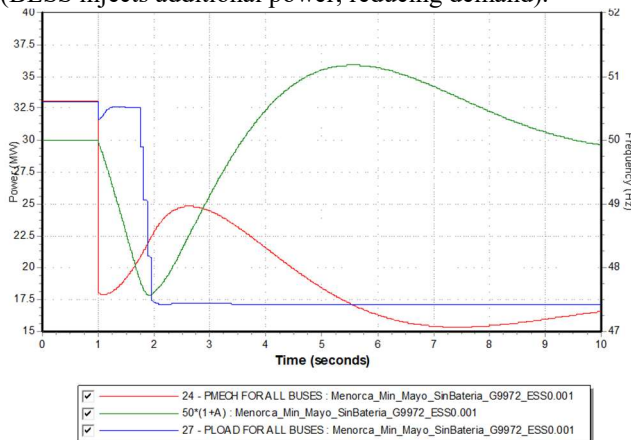

Figure 3: Power system A - Response of the system to the outage of unit G in terms of frequency, mechanical power and load demand without BESS.

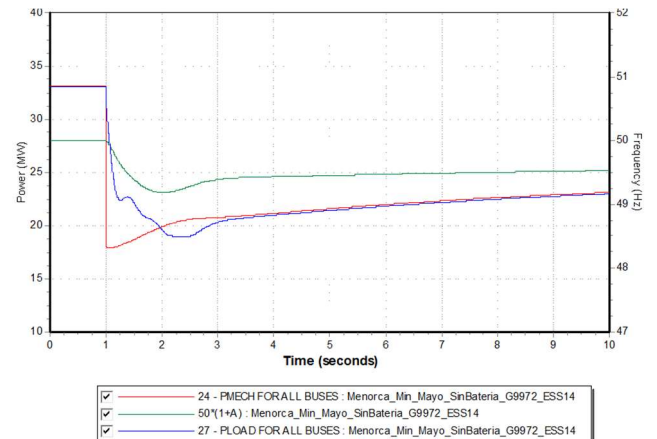

Figure 4: Power system A - Response of the system to the outage of unit G in terms of frequency, mechanical power and load demand with BESS.

Finally, Figure 5 summarizes the results for the remaining outages. Figure 5 shows for each BESS size, the total amount of shed load and the accumulated minimum frequency deviation. It can be seen that for scenario 2, a BESS of 8 MW is sufficient to avoid load shedding, whereas for scenario 1, a BESS of 14 MW is necessary.

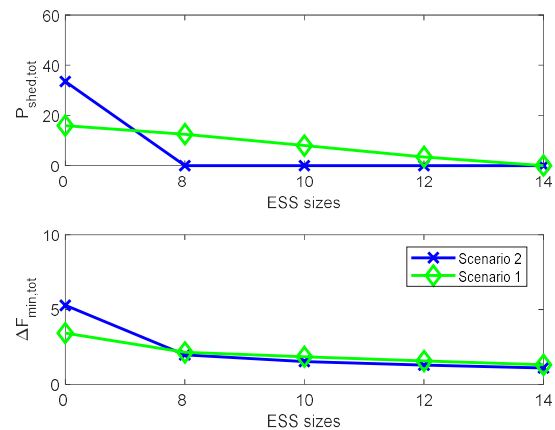

Figure 5: Power system A - Impact of different BESS size on the total amount of shed load and accumulated frequency deviation.

### System B

Table 5 in the appendix shows the two generation dispatch of power system B. The outages of generating unit G4 and G6 in scenario 1 and 2 represent the most critical incident, leading to a minimum frequency far below 49 Hz. By applying equation (7), the critical power loss of G4 and G6 amounts to 4.5 and 2.2 MW, respectively, in order the frequency not to fall below 49 Hz. Table 2 shows the estimated BESS sizes of power system B. It results that a BESS of at least 6.6 MW is needed. This corresponds to about 9% of the installed generation capacity.

BESS (MW)	
1	6.6
2	5.9

Table 2: BESS power capacity for the two considered scenarios.

In order to validate the estimated BESS size, the outage of each generating unit for both generation dispatch scenarios has been simulated. BESS sizes of 0, 2, 4, and 8 MW have been considered. The BESS's droop is set to 1.33% and the emulated inertia is equal to 20 s.

Figure 6 and Figure 7 show the response of the system to the outage of generating unit G6 in scenario 2 with and without a BESS of 8 MW. The BESS of 8 MW clearly avoids load shedding, visible in the demand of Figure 6.

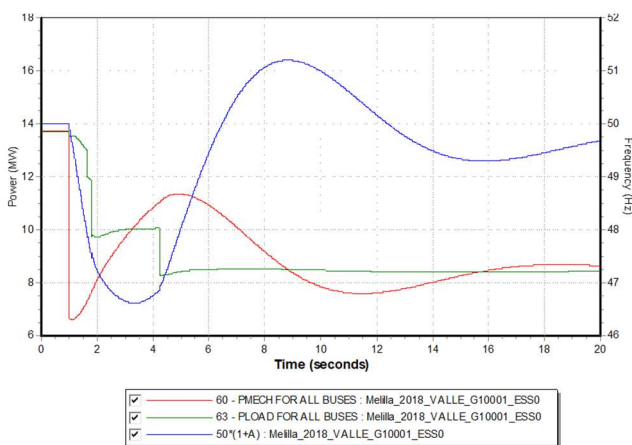

Figure 6: Power system B - Response of the system to the outage of unit G in terms of frequency, mechanical power and load demand without BESS.

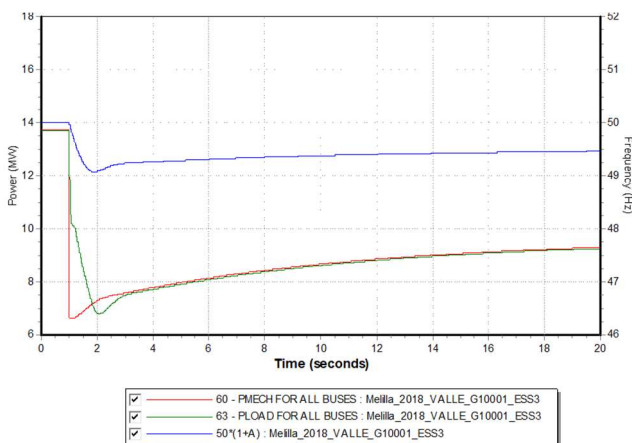

Figure 7: Power system B - Response of the system to the outage of unit G in terms of frequency, mechanical power and load demand with BESS.

Finally, Figure 8 summarizes the results for the remaining outages. Figure 8 shows for each BESS size, the total amount of shed load and the accumulated minimum frequency deviation. It can be seen that for both scenarios, a BESS of 8 MW needed to avoid load shedding. This is insofar interesting since in the second scenario 7.1 MW

have been lost; the reason is that remaining generating units are rather slow, causing that a BESS of only 4 MW would not be sufficient to avoid load shedding.

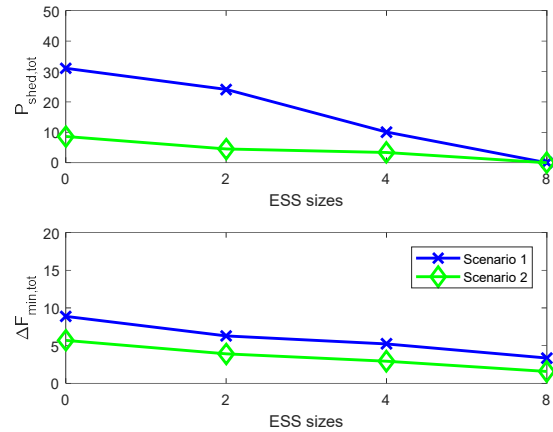

Figure 8: Power system B - Impact of different BESS size on the total amount of shed load and accumulated frequency deviation.

## CONCLUSIONS

This paper has presented a method to size battery energy storage systems (BESSs) to minimize underfrequency load shedding in isolated power systems. The proposed method has been applied to two isolated Spanish power systems. It can be concluded that the size of the BESS to avoid load shedding, depends on the size of the disturbance, the parameters of the BESS controls as well as the dynamics of the generating units. In case of slow generating units and fast energy storage systems, the size of the energy storage system is very much related to the largest considered disturbance and usually slightly smaller. For the considered systems, a BESS of about 6% to 9% of the installed generating capacity is sufficient.

## ACKNOWLEDGMENTS

The authors acknowledge the fruitful comments and data provided by A. Barrado and G. Del Alcazar of ENDESA S. A.

## REFERENCES

- [1] L. Sigríst, I. Egido and L. Rouco, "A Method for the Design of UFLS Schemes of Small Isolated Power Systems," *Power Systems*, IEEE Transactions on, vol. 27, pp. 951-958, 2012.
- [2] P. Mercier, R. Cherkaoui and A. Oudalov, "Optimizing a Battery Energy Storage System for Frequency Control Application in an Isolated Power System," in *IEEE Transactions on Power Systems*, vol. 24, no. 3, pp. 1469-1477, Aug. 2009.
- [3] G. Delille, B. Francois and G. Malarange, "Dynamic Frequency Control Support by Energy Storage to Reduce the Impact of Wind and Solar Generation on

Isolated Power System's Inertia," Sustainable Energy, IEEE Transactions on, vol. 3, pp. 931-939, 2012.

- [4] N. S. Jayalakshmi and D. N. Gaonkar, "Performance study of isolated hybrid power system with multiple generation and energy storage units," in Power and Energy Systems (ICPS), 2011 International Conference on, 2011, pp. 1-5.
- [5] Ioan Serban, Remus Teodorescu, Corneliu Marinescu, "Energy storage systems impact on the short-term frequency stability of distributed autonomous microgrids an analysis using aggregate models", Renewable Power Generation IET, vol. 7, no. 5, pp. 531-539, 2013.
- [6] Y. Tan et al., "Enhanced Frequency Regulation Using Multilevel Energy Storage in Remote Area Power Supply Systems," in IEEE Transactions on Power Systems, vol. 34, no. 1, pp. 163-170, Jan. 2019.
- [7] Anderson, P. M. Power system protection. IEEE Press, Piscataway (NJ, USA), 1999.

## APPENDIX

	G1	G2	G3	G4	G5	G6	G7	G8
1	9.0	9.0	0.0	0.0	0.0	15.0	0.0	0.0
2	8.0	7.0	0.0	0.0	0.0	10.0	0.0	0.0

Table 3: Generation dispatch scenarios of power system A.

	G1	G2	G3	G4	G5	G6	G7	G8
K	20	20	20	20.6	20.6	14.5	6.2	6.2
T (s)	6.4	6.4	6.4	0.6	0.6	0.6	0.7	0.7
H (s)	2	2	2	4.55	4.55	6	3.48	3.48
Mbase (MVA)	20	20	20	46.82	46.8	64.82	81.13	81.13
Pmax	15.8	15.8	15.8	37.5	37.5	25	25	25
Pmin	7	7	7	7	7	7	7	7

Table 4: Parameters of the simplified power system model of power system A.

	G1	G2	G3	G4	G5	G6	G7
1	4.1	4.3	0.0	10.9	0.0	10.8	10.7
2	0.0	1.5	5.1	0.0	0.0	7.1	0.0

Table 5: Generation dispatch scenarios of power system B.

	G1	G2	G3	G4	G5	G6	G7
K	20	20	14.3	20	25	20	20
T (s)	10.7	10.7	7.7	10.7	0.5	6.0	5.8
H (s)	2.1	2.8	2.4	2.8	7.0	4.3	4.3
Mbase (MVA)	7.2	7.2	11.9	14.5	18.4	15.8	15.8
Pmax	5.8	5.8	9.5	12.3	14.7	12.6	12.6
Pmin	1	1	1	1	1	1	1

Table 6: Parameters of the simplified power system model of power system B.