

Version:

This article is a submitted version. Please cite the published version:

<https://doi.org/10.1016/j.rser.2024.114904>

Citation for published version:

Domínguez, M., Fernández-Cardador, A., Fernández Rodríguez, A., Cucala, A.P., Pecharromán, R.R., Urosa Sánchez, P., Vadillo Cortázar, I., Review on the use of energy storage systems in railway applications. *Renewable & Sustainable Energy Reviews*. Vol. 207, pp. 114904-1 - 114904-21, Enero 2025. <https://doi.org/10.1016/j.rser.2024.114904>

Review on the use of energy storage systems in railway applications

Authors

Dominguez, M.^{a*}, Fernandez-Cardador, A.^a, Fernandez-Rodriguez, A.^a, Cucala, A.P.^a, Pecharromán, R.R.^a, Urosa Sánchez, P.^b, Vadillo Cortázar, I.^b

^a=Institute for Research in Technology (IIT), ICAI School of Engineering, Comillas Pontifical University, 23 Alberto Aguilera St, 28015 Madrid, Spain.

^b=ADIF, 4-6 Titán St, 28045 Madrid, Spain.

*=Corresponding author: e-mail address: mdominguez@comillas.edu (M. Dominguez)

Funding

This study has been funded by the International Union of Railways (UIC) in the "Methods of energy storage for railway systems UIC RESS RSMES" project 2020/RSF/669. (Funding partners ADIF, INFRABEL, NETWORK RAIL, RFI, NS, SBB and SZCZ).

Abstract

The imperative for moving towards a more sustainable world and against climate change and the immense potential for energy savings in electrified railway systems are well-established. The utilization of regenerative energy generated during train braking represents a valuable opportunity for maximizing these savings. Consequently, the incorporation of energy storage systems to store and reuse this regenerative energy, has emerged as a crucial strategy. Energy storage technologies have become indispensable in achieving overall energy efficiency objectives.

The wide array of available technologies provides a range of options to suit specific applications within the railway domain. This review thoroughly describes the operational mechanisms and distinctive properties of energy storage technologies that can be integrated into railway systems. A research review is carried out to determine the operating parameters of each technology, which are subsequently analysed and compared against the desired characteristics essential for railway applications. Based on this analysis, this research propose recommendations regarding the most suitable energy storage technologies. The insights obtained from the analysis are supported by real-world examples of energy storage system implementations in railway systems worldwide.

Highlights

- Energy storage systems help to reduce the consumption of railways systems through the utilization of regenerative energy generated during electrical train braking.
- A wide range of energy storage technologies is available and an examination of their characteristics is essential to determine their most suitable applications.
- Energy storage systems for railway applications must exhibit the capacity to operate rapidly through numerous cycles each day, deliver high currents, ensure long lifetimes, maintain high efficiency, and incur minimal costs.

Keywords

Energy storage, railways systems, regenerative energy, energy efficiency, on board, wayside

Word count

9936 words

List of abbreviations

BESS	Battery
EDLC	Electric double layer capacitor
ESS	Energy storage system
FBESS	Flow battery
FC	Fuel cell
FESS	Flywheel
LA	Lead-acid battery
LCC	Life cycle cost
Li-ion	Lithium-ion battery
LRV	Light rail vehicles
NaS	Sodium-Sulphur battery
Ni-Cd	Nickel-Cadmium battery
Ni-MH	Nickel-Metal hydride battery
RS	Railway systems
SMES	Superconducting magnetic energy storage

TCC	Total capital cost
VRB	Vanadium redox battery
WESS	Wayside energy storage system

1. Introduction

Climate change has become one of the major concerns of the population [1] and, consequently, of the public authorities and private companies that even use sustainability as a marketing strategy [2]. Large energy consumers are forced to reduce their consumption, not only from an environmental perspective but also in terms of costs [3]. This includes railway companies and infrastructure managers. According to the International Union of Railways (UIC) data, the rail sector was responsible for 336 million tCO₂ emissions in 2015 [4]. In this regard, the UIC Environment, Energy and Sustainability Platform sets out specific targets to achieve by the European railway sector such as improving energy efficiency by 30% in 2030 and by 50% in 2050 (relative to the base year of 1990) [5]. Accordingly, transit operators are constantly looking into new ways to improve the energy efficiency in all the aspects involved: design of the rolling stock [6], scheduling [7,8] driving [9,10], stations [11], research of new technologies [12] etc.

Over half of the rail network in Europe is electrified, a percentage that continues to grow. Given adequate funding and political commitment, there exist the potential to electrify it entirely. If the European Union successfully accomplishes its goal of complete electricity decarbonization by 2050, rail transportation could be the first zero-carbon major mode of transportation [13]. Nevertheless, another great advantage comes with the use of electric trains. They are powered by electric drives consisting of induction motors, which function as motors when fed by the grid to propel the train, and as generators when the electric brake is used to decelerate. This process, known as regenerative braking, converts the train's kinetic energy into electrical energy. However, the use of this recovered energy is restricted to instances where one train is simultaneously accelerating while another is braking within the same electrical sector [7]. If there is no such synchronization between the trains, the regenerated energy, after feeding the auxiliary systems, attempts to be reinjected into the utility grid if feasible. However, this may not always be achievable. These energy flows are represented in Figure 1 where the braking train tries to send regenerated energy to the powering train nearby.

In alternating current (AC) systems, power can be returned to the grid if there are no trains near the braking one. In direct current (DC) systems however, the power cannot be fed back through the substations due to the rectifier filters preventing the conversion from DC to AC. That energy,

therefore, has to be dissipated through resistors on board the trains in the form of heat, and consequently lost. To allow their reinjection, DC systems need to have inverters at the substations involving relevant investments [14–16].

Besides the electric network configuration, the sum of recovered energy depends on various factors including service intervals, train power profiles, types of rolling stock, line voltage, track profile, length of feed sections, and power needs for train auxiliary systems [17–19]. The potential of braking energy in electrified railways typically ranges from 40% to 45% of the total energy consumed [20–22], however, measurements indicate only a 19% recovery rate [23]. Another solution to improve these numbers is to install energy storage systems (ESSs) either on trains or at substations [24,25]. Unlike with the use of inverters, the energy is retained within the system, preventing losses that typically occur in transformers and rectifiers.

Some verification tests conducted revealed that ESSs were capable of storing approximately 21% of the total energy generated from regenerative braking. This implies a reduced need for dissipating energy through resistors, resulting in a significant cost reduction. For example, 30% energy saving is achievable from the on board MITRAC Energy Saver from Bombardier and the stationary SITRAS SES ESS from Siemens [26] included in Table 10 and Table 11.

ESSs offer additional advantages for an improved performance of railway systems (RS), including

- Reducing power peaks and their economic costs despite the demand increase [20,27].
- Voltage stabilization [25,28].
- Increase of the maximum power in DC systems [20].
- Serving as a substitute for a new substation in areas where voltage tends to drop significantly [29,30].
- Reduction of energy consumption without affecting operation and punctuality [31].
- Enhancing network performance during train acceleration while maintaining the safety of the electrical supply network [31].
- Power autonomy in places where an overhead line cannot be installed.
- Support in case of power failure supply to reach a safe place [32].

Furthermore, the regenerated energy stored can be used not only to meet traction demands but also for other ends, including charging electric vehicles [33–37] or fulfilling the energy requirements of train stations. In short, the application of ESS in RS could reduce the costs of train operation, energy consumption and station demand, making the whole system more sustainable and efficient.

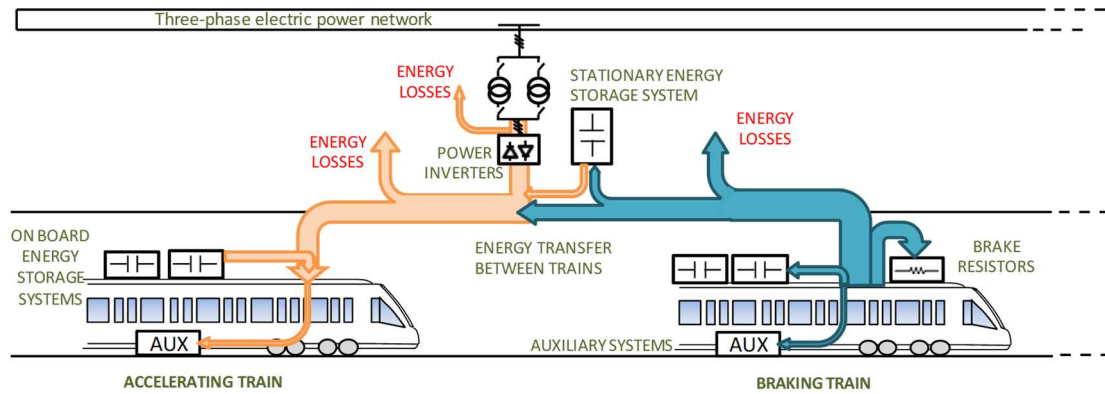

Figure 1: Flow of energies and operation of on board and stationary energy storage systems within a railway system

On this basis, the object of the study is to analyse the latest and diverse ESS technologies to determine the more suitable device to store energy in RS. This work represents the initial outcome of the project 'Methods of Energy Storage for Railway Systems - UIC RESS RSMES,' sponsored by the UIC. The ultimate aim of the project is to evaluate the energy savings within a RS through the simulation of an ESS at a station. For this initial task, a comprehensive literature review has been conducted to assess the state of research on ESS technology, with a specific focus on its application in RS.

Due to the advantages that ESS present for improving energy efficiency in RS, there has been a surge in articles about this topic. These articles cover a wide array of topics, ranging from specific case reports [38–47] to modelling and optimization [48–58] studies, as well as investigations into either on board [59,60] or stationary applications [61–63], and their influence on train speed profiles design [64,65]. Some of them look into future prospects such as integrating ESS into shared infrastructures between DC Railway Networks and DC Micro Grids [66,67]. While comprehensive reviews are also available, many lack data such as costs [26], Ragone plots [68–70] or both [71–73], which this work aims to provide.

This review distinguishes itself for the extensive compilation of referenced data and transparent presentation of sources, which are used to elaborate the Ragone plots, and offers valuable insights to inform decision-making processes in RS. The review of existing technologies, presented in section 2.2 allows, after defining their parameters in section 2.1, to examine the advantages and disadvantages that each one may present when chosen for application in a RS. Additionally, a review of the state of the art of real applications has been conducted in section 2.4, which can be seen in Table 10 and Table 11. A thorough extraction of technical data, listed in Table 13 and Table 14 in section 3, enables the creation of Ragone plots with referenced data

and the analysis of results to advise the most suitable decision based on objective criteria, discussed in section 4. This approach, including data extraction, analysis, and selection, without omitting or duplicating sources, sets it apart from existing studies in the field.

2. Railway Energy Storage Systems

ESSs are characterized by a number of operating parameters whose values differ between technologies. Their assessment is necessary for the correct evaluation of the most suitable device for each case. These parameters are described in section 2.1. Then, the different types of energy storage technology are presented in 2.2, describing those that can be applied in RS and highlighting their strengths and weaknesses. The other components necessary for the operation of an ESS are described in 2.3 describes. Finally, subsection 2.4 is dedicated to the two main applications of ESSs in RS.

2.1 ESS parameters

- Energy and power rating: The energy rating represents the energy that can be stored and also the capacity of the ESS. The power rating characterises the maximum power that the device can provide during both the charge and discharge phases.
- Power and energy density: The energy density is the amount of energy that an ESS can supply per unit of volume (Wh/l). A higher energy density implies greater energy storage in a smaller volume. This holds significance in applications like ESSs on board trains for catenary free operation since a higher energy density in the device favours train autonomy.
- The power density is the rated output power per unit of volume (W/l). When a short discharge period is required, such as in railway applications, a high power density device is needed [74]. Meanwhile, energy density is more relevant when a prolonged duration of charge and discharge is necessary.
- Specific power and energy: Specific energy and specific power represent the total energy and power per unit of weight (Wh/kg and W/kg). It is particularly important contemplate them when considering weight restrictions of the device.
- Charge and discharge power: The quantity of energy that can be stored or discharged in a certain amount of time is known as the charge or discharge power. The discharge power is a dynamic value that can change based on the particular operating conditions and the ESS's state of charge, whereas the power rating indicates a device's maximum capacity to handle power.

- Charge and discharge time: The charge time refers to the duration required to refill the ESS at its maximum charge power [75] and is proportional to the size of the system [76]. Conversely, the discharge time is the time needed by an ESS to supply all the available stored energy at its maximum power [77] (Equation 1).

$$t = \frac{E_{out}}{P_m}$$

Equation 1

- In ESSs for RS, fast charging and discharging times of 10s to 1min are required, and this is more significant than high energy capacity when dealing with frequent and pronounced load fluctuations [29].
- Operational and response time: Operational time denotes the duration during which an ESS can reasonably sustain an average discharge power. The response time indicates the duration required for the ESS to reach its maximum power output from a stationary state.
- Self discharge: All the ESSs dissipate an amount of energy during the time they are not being used. This is known as self discharge.
- Depth of discharge: The extent to which an ESS can be discharged in relation to the total capacity to protect their lifetime, is known as the depth of discharge and it is typically provided by the manufacturer. For example, certain ESSs should not be discharged, beyond 20-30%.
- Efficiency and round trip efficiency: The quantity of available energy that the ESS is able to supply (E_{out}) will be lower than the energy initially stored (E_{in}) because of the losses involved and the depth of discharge. This ratio, defines the efficiency as seen in Equation 2.

$$\eta = \frac{E_{out}}{E_{in}}$$

Equation 2

- This definition is derived from a single operational condition, however there are losses during charging, no load and self discharge (each system has different typical losses such as mechanical, ohmic or chemical-related losses [78]). That is why efficiency is usually defined for a whole cycle [77]. So the round-trip efficiency (%) is the ratio during a complete discharge/charge cycle.
- Lifetime and cycle life: The operational window for an ESS to function at its intended capacity is restricted. This time can be measured in years (lifetime) or number of cycles (cycle life) considering that one cycle corresponds to a single charge and discharge sequence.

Ultimately, in RS, the focus is on finding a device capable of supplying high currents in a short time, (high power peaks of charge and discharge, usually ranging from 0.1 and 10MW [79]), able to operate many cycles (typically between 100,000 and 300,000 per year), possessing medium energy storage capacities [68] and having a long lifetime. Transit Operators usually anticipate a minimum design lifespan of 20 years for new equipment, including ESSs [32].

There is a wide array of energy storage technologies but, at the same time, they are needed in different applications and in each of them they must meet different requirements. A bibliography review has been carried out with an exhaustive investigation of previous studies of storage technologies and assortment of data for the understanding of the operation and features of each ESS with the application to RS in mind.

2.2 ESS overview

As mentioned before, energy storage has an essential function in the ongoing trends to improve energy efficiency. There is a considerable amount of money being invested in this field, resulting in fast development of a wide variety of different technologies. Most studies classify them into five main technologies based on the processes they use to transform electricity into other forms of energy: chemical, electrochemical, mechanical, electric and thermal [80–91]. The classification is shown in Figure 2 where technologies not applicable in RS are shown with dashed lines.

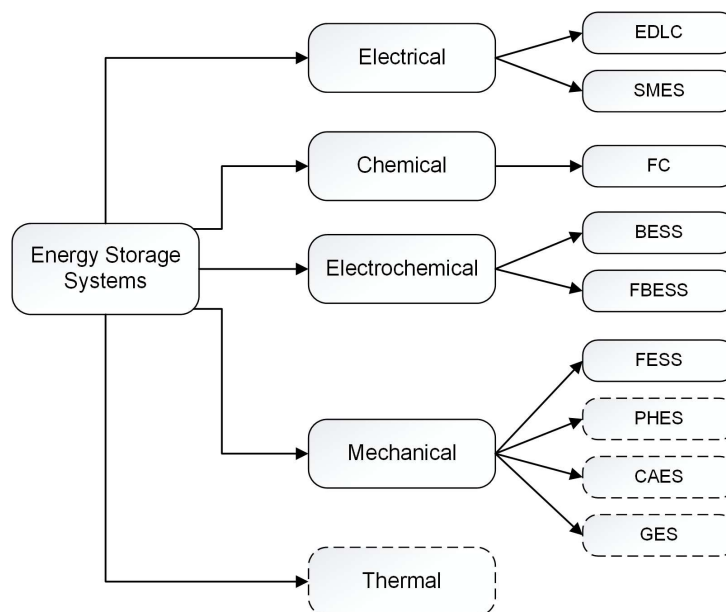

Figure 2: Classification of EESs according the form of energy stored (In dashed lines technologies unsuitable for railway systems)

2.2.1 Electrochemical energy storage

The electrochemical ESSs are primarily classified into two types: battery ESS, where the charge is stored within the electrodes, and flow battery ESS, where the charge is firstly stored within a fuel and then supplied onto the electrode surfaces [92].

2.2.1.1 Batteries (BESS)

A battery is composed of one or more electrochemical cells that transform stored chemical energy into electrical energy [93]. Due to their performance, batteries find extensive usage improving energy efficiency in electrified railways like trams and metro trains [26]

Regarding costs, average global battery prices fell by 6% in 2021 continuing a long-term trend. Followed by a rising in prices in 2022 due to supply-side shocks [94].

There are many types of batteries each with its own characteristics and applications. The following are the most commonly used and applicable in RS.

2.2.1.1.1 Conventional lead-acid batteries (LA)

The LA battery stands as the earliest form of rechargeable battery [95]. They are less expensive than other battery technologies but fairly larger and heavier and bulkier. It also takes longer times to charge them and have a short cycle life, low energy and power densities, and cannot be discharged deeply [86].

Table 1: Strengths and weaknesses of lead-acid batteries

Strenghts	Weaknesses
Low cost Established technology	Heavy and bulky Long time to charge Short lifetime Low energy density Low power density Cannot be discharged deeply

LA batteries have a long history of utilization in railway applications. In Japan, they were installed in two lines in 1912 and 1914, in battery posts in parallel with the power substation. After approximately 15 years of usage, the traditional LA batteries were phased out due to challenges in maintenance and the decision to construct a new substation. However, in 1980, Japan National Railway set up a new LA battery post at Nakajima station for three years to conduct verification testing [26].

2.2.1.1.2 Nickel-Cadmium (Ni-Cd)

As the previous batteries, Ni-Cd technology is well-established. They have longer cycle life, low maintenance requirements and are deemed to be very reliable. In addition, they have high durability, a low self discharge and can resist a wide temperature range of operation. Its main limitation is the memory effect and the environmental hazard of cadmium [73]. This, together with the recycling directives makes their future uncertain [96].

Table 2: Strengths and weaknesses of nickel-cadmium batteries

Strengths	Weaknesses
Proven technology	Memory effect
Longer lifetime	Hazardous material
Low maintenance	
Low self discharge	
High sturdiness	
Wide temperature operating range	

2.2.1.1.3 Lithium-ion battery (Li-ion)

Among the array of battery types, Li-ion batteries are increasingly significant in electrical energy storage because of their high energy density [74]. They also have very high efficiency, no memory effect and present low self discharge. However, their cost remains elevated for large scale applications and it is unlikely to drop given their usage in devices such as laptops, cameras, phones, and electric vehicles coupled with limited reserves [79,97].

Regarding safety, Li-ion batteries present a risk of a thermal runaway since the majority of metal oxide electrodes used are prone to thermal instability. In consequence, the advancement of Li-ion battery technology is still ongoing, presenting ample opportunities for further progress [84].

Table 3: Strengths and weaknesses of lithium-ion batteries

Strenghts	Weaknesses
High energy density	High price
Light weight	Safety risk (fire)
No memory effect	
Low self discharge	
High efficiency	

2.2.1.1.4 Nickel-Metal hydride battery (Ni-MH)

Ni-MH batteries, use hydrogen instead of cadmium in the negative electrode, which eliminates their environmental hazards. Furthermore, Ni-MH batteries feature higher specific energy and energy density, and most notably, they lack the memory-effect issues of Ni-Cd batteries. On the downside, overcharging can lead to excessive heat generation and potential hydrogen release, posing a serious fire risk which makes necessary a complex charging system. Additionally, when subjected to high current discharges, the lifespan of Ni-MH batteries is significantly reduced (200-300 cycles) [73]. Thus, despite having the required energy storage density, their lifespan falls considerably short of meeting the demand of light rail vehicles (LRV) for example, which typically require 2 million cycles over 10 years [98].

Table 4: Strengths and weaknesses of Ni-MH batteries

Strenghts	Weaknesses
High energy density	Safety risk (fire)
High specific energy	Low cycle life
No memory effect	
Environmentally friendly	

2.2.1.2 Flow batteries (FBESS)

FBESS work in a different way than the conventional ones. The energy stored in FBESS resides within two soluble liquid electrolytes, contained in separate external tanks. These electrolytes flow through electrochemical cells during charging and discharging phases, transforming chemical energy into electrical energy. The use of the external tanks make the self discharge practically non existent [99]. Also, the dimensions of the tanks determines the energy density of the FBESS (which allows to provide almost unlimited capacity [86]), whereas the power density is influenced by the design of electrochemical cell. This make them suitable for power and energy related applications [90]. Disadvantages are associated to complexity of construction and cost. The need for tanks, plumbing and other non-electrochemical elements enhance the probability and cost of repair and electrolyte leakage. Furthermore, the auxiliary equipment needed to pump electrolytes from tanks to cells contributes to efficiency losses. They also require significantly larger space compared to other electrochemical storage technologies [100]. Vanadium Redox Batteries, described as follows, are the most promising option.

2.2.1.2.1 Vanadium redox battery (VRB)

VRBs have several advantages over other BESS. First, electrolyte production is relatively simple, inexpensive, and mobile. Second, electrolyte cross contamination would only necessitate recharging, and the electrolytes do not undergo degradation [101]. So, they do not need replacement, and overall maintenance is minimal [100]. Third, these batteries can be fully discharged without experiencing any damage.

Table 5: Strengths and weaknesses of vanadium redox batteries

Strengths	Weaknesses
No degradation	High cost
Long lifetime	Environmental concerns (toxicity)
Low maintenance	Low maturity
Can be fully discharged	
Low self discharge	

One of the challenges that has limited the commercialization of VRB so far is the high cost of the ion-exchange membrane [86]. They also raise certain environmental and safety concerns due to

the potential toxicity associated with vanadium [102]. Moreover, since pumps recirculate the electrolyte, heat release is linked to both the charging and discharging processes. Consequently, they require cooling systems which increase the cost and size of VRB systems [103].

2.2.2 Chemical – Fuel cells (FC)

FCs receive an inflow of fuel (or active material) from an external source that must be replenished [104]. Due to that, FCs might be categorized as generation instead of storage devices. They combine the advantages of both, engines and BESS. Under load conditions, FC performance resembles that of BESS and they share similarities with engines as they can function as long as there is a supply of fuel [95].

When there is an excess of energy, electricity is utilized for the process of electrolyzing water producing hydrogen. This hydrogen, together with oxygen from the atmosphere, is then employed, when needed, to generate electricity again [95]. This conversion can occur straight from the fuel such as hydrogen, or indirectly through an initial processing step known as reforming, which converts the fuel into a hydrogen-rich gas [105].

Lately, significant attention has been directed towards hydrogen, recognized as one of the cleanest, most efficient and lightweight fuels accessible [106]. Additionally, it can be efficiently stored and reused. Nevertheless, hydrogen is not found in its elemental state in nature and must be derived from primary energy sources [95].

FC provide high specific energy and excellent cycle performance with a long lifespan of 15 years [95]. They can work continuously providing the required flows are maintained [104]. Therefore, it can be considered a long-term ESS technology even though considering its low roundtrip efficiency and high capital cost yet [107].

In the railway sector, FC have been primarily utilized in diesel trains, as demonstrated by examples like the 'Kiha E200' in Japan, which has shown a 9% energy improvement compared to previous diesel trains. Also in Canada in the "Evolution Hybrid Locomotive" as shown in UIC report [108]. In Europe, hydrogen power finds application in railway traction through Alstom's "Coradia iLint," active since 2018. This hydrogen electric multiple unit runs on a regular basis on a German regional line together with traditional diesel multiple units [60]. Research is also being carried out on hybrid systems with FC and Li-ion batteries [109].

Table 6: Strengths and weaknesses of fuel cells

Strenghts	Weaknesses
High specific energy High lifetime	Low efficiency High cost Low maturity

2.2.3 Mechanical – Flywheels (FESS)

Mechanical ESS comprises compressed air energy storage, pumped hydroelectric storage , gravity energy storage and flywheel energy storage (FESS) [92]. Only the latter will be described for their applicability to RS.

FESSs store rotational energy. They are charged accelerating a motor and discharged when the same motor performances as a generator producing electricity. The total energy potential depends on the speed and size of the rotor, whereas the power rating is determined by the motor/generator [110].

FESSs have several benefits compared to chemical energy storage. They have a considerable durability enabling frequent cycling with no impact on performance [93]. They also have high efficiencies, quick recharge, high power density, easy maintenance and fast response times. Typical applications are for high power and short duration requirements such as RS [110]. Moreover, FESSs have few adverse environmental effects. They do not use hazardous materials, and produce no emissions [111].

Table 7: Strengths and weaknesses of flywheels

Strenghts	Weaknesses
High lifetime High efficiency Fast response time Quick recharge High power density Environmentally friendly Easy maintenance	Low energy density High self discharge Rotor failure risk

The disadvantages of FESS are its low energy density, and significant standby losses [112] which can lead to self discharge of up to 20% of stored capacity per hour [110]. Moreover, one critical safety concern in FESS design is the possibility of rotor failure while it is in motion. So, large steel containment systems are utilized to prevent harm by high-speed fragments [111].

2.2.4 Electric

Energy storage is also possible through supercapacitors and superconducting magnets, which make use of electric and magnetic fields, respectively. These devices offer medium energy density and high power capabilities. [95].

2.2.4.1 Electrical double layer capacitors (EDLC)

EDLC, also known as ultracapacitors or supercapacitors, are storage devices that work on the same principle as conventional electrolytic capacitors but have a higher storage capacity and lower internal resistance [68].

EDLCs enable the setup of energy storage units with compact dimensions and adaptability to various voltages. They excel in efficiency, managing dynamic load changes, and supporting cyclic operations [113]. Additionally, they have moderated maintenance costs and offer scalable energy storage capacity, customizable to each train's needs.

Table 8: Strengths and weaknesses of supercapacitors

Strenghts	Weaknesses
High efficiency	Low energy density
High capacity	High self discharge
Low maintenance	
High power density	
Environmentally friendly	
Low heating levels	
Fast response time	
Safe	

EDLCs have higher self discharge ratio and lower energy density compared to BESS [114], but can deliver up to thousands of times the power of a battery with equivalent mass [74]. Therefore, EDLCs are better suited than BESS for usages that require a high cycle life and a rapid charge or discharge times. As a result, it is commonly employed for on board energy storage LRVs, even without catenary [115], leading to notable cost reductions [116–119]. Some studies have also explored its benefits on board diesel trains [120] or hybridised with BESS to leverage the strengths of both technologies [121]. They are listed in Table 10. Additionally, stationary applications are found at substations, for voltage stabilization and energy saving purposes [122], along with commercial products such as the SITRAS SES (stationary energy storage) developed by Siemens [31] [123] which has installations in Spain, Germany and China [124] as included in Table 11.

Other strong points of EDLCs are their environmentally friendly materials, minimal heating levels, and the enhanced safety achieved [29].

2.2.4.2 Superconducting magnetic energy storage (SMES)

SMESs use the magnetic field created by a direct current flowing through a coil cooled below its superconducting critical temperature to store electric energy [68]. While some energy losses occur in the cooling system, those within the coil are nearly negligible [74].

SMESs are capable of virtually immediately discharging substantial amounts of power, and go through an unlimited number of charging and discharging cycles with high efficiency [74]. They may discharge nearly all of the stored energy after hundreds of full cycles with minimal degradation compared to BESS [110]. SMES are therefore appropriate for applications that need a continuous mode of operation and full cycling. [104]. Although their features suggest potential suitability for RS, especially for stationary ESSs [68] no documented cases of SMESs being utilized specifically in railway applications are found. Their primary use has been in applications related to network stability. Nevertheless, a couple of simulation studies have explored the utilization of SMES in traction substations aiming to compensate the fluctuating power. Yet, they need to be combined with a battery as a hybrid system [125,126]. These hybrid systems look promising, but as mentioned, only simulated results are currently available.

Table 9: Strengths and weaknesses of superconducting magnetic energy storage

Strengths	Weaknesses
High power density	High cost
Fast response	Strong magnetic fields
Long lifetime	High self discharge
High efficiency	Low energy density
Low degradation	

Besides the high capital and operational costs due mostly associated with the refrigeration system, a significant concern is the powerful magnetic fields that are produced, particularly when extremely big capacities are involved. [68]. The high self discharge and the sensitivity of the coil to small temperature variations are other weaknesses [110].

2.2.5 Thermal

For the sake of mentioning all the technologies available as seen in Figure 2, thermal ESS is cited but not detailed due to the non-applicability to RS. Thermal ESS include devices designed to store electricity or surplus heat resources in the form of thermal energy until they are required to meet energy demands.

2.3 Components of Energy Storage Systems

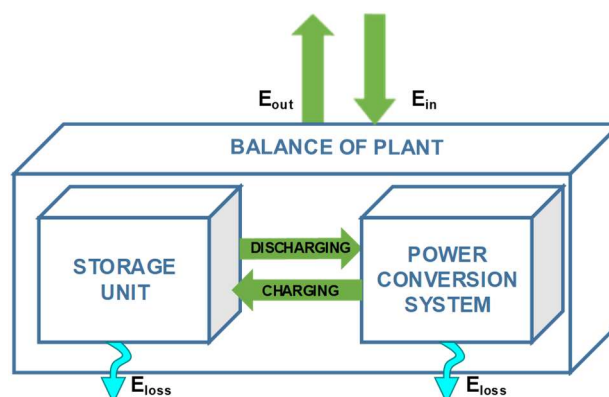

Figure 3: Components of an ESS

An ESS contains three elements as shown in Figure 3: The power conversion system, the storage unit and the balance of plant:

- The storage unit is the energy storage element itself, that is, all the equipment needed to store and discharge energy. For example, the battery banks.
- The power conversion system comprehends all the electronics that the ESSs need to properly work in the railway network. Their specific topology varies depending on the type of storage device and its application. Nevertheless, they usually are power converters with switchgears that adapt the voltage, current and waveform of the electricity recovered during braking to the working conditions of the ESS [68]. Also, measurement and control systems may be included here which are important for maintenance and ensuring right functionality [32].

Generally, power converters utilized in ESSs for RS should possess the following characteristics [79]: high efficiency, fast response and the capability to enable bidirectional energy flow effectively controlling the charging and discharging processes of the ESS, put up with high power peaks and manage high rated power.

- The balance of plant is comprised of components such as the building or enclosure, foundations, miscellaneous switchgear, hardware, cooling systems, protections, and any additional assets and services required [111,127].

2.4 Applications of ESSs in RS

ESSs in railway applications can work in two different ways: as stationary devices in the substations or alongside the track, or on board the trains.

2.4.1 ESSs on board the trains

Feeding the regenerative energy back into storage devices at substations involves transmission losses. These losses are avoided by installing the device on board vehicles [128]. A representation is shown in Figure 1. This simplifies the management of recovered energy as control becomes independent of traffic conditions [68]. However, the train mass increases [24], [119] and the vehicle requires extra space [119]. This additional mass causes a slightly higher energy demand which has to be considered in the total energy balance [65,129]. Also, when maintenance is needed for the device, it requires the train to be out of service.

To install an ESS on board a train (typically a tram) it is essential to have knowledge of the energy required to feed both traction and auxiliary systems, especially in the case of catenary free

operation. The required energy depends on several factors, including the track profile, distance between stations, operational modes like commercial speed, and comfort levels [130].

Several projects utilize ESS on board the trains as can be seen in Table 10. Most of them are utilized in LRV, making the self-propulsion Battery System for N700S Shinkansen particularly significant. It is the world's first high-speed train equipped with a self-propelled battery system (in this case a Li-ion battery). It can be used in the event of power outages allowing the train to independently reach a safe location for passenger evacuation [131,132]. Also worth mentioning are the commercial hybrid devices from Siemens (Sitras HES) [133] and Adetel [134], both consisting of EDLC and a different type of battery in each case. This allows them to leverage the advantages of the EDLC (high power density and rapid response) and the battery (high energy density). Attention should be addressed toward this type of hybrid devices in the medium term.

Table 10: Application of on board ESSs in railway systems

EXAMPLES OF ON BOARD ESS IN RS						
COMERCIAL NAME	MANUFACTURER	ESS	PLACE and TRAIN NAME	PURPOSE	YEAR	REFERENCES
ACR	CAF	EDLC	Seville, Spain (Urbos 3)	Energy saving. Catenary free operation	2010	[98,135–137]
			Zaragoza Tramway, Spain (Urbos 3)	Catenary free operation	2011	[135,136,138]
			Cuiabà, Brazil (Urbos)		2012	[60]
			Tallin, Estonia (Urbos)	Catenary free operation	2013	[60,139]
			Kaohsiung, Taiwan	Catenary free operation	2015	[60,138,139]
			Luxembourg (Urbos 3)	Catenary free operation	2020	[138]
			Malaga, Spain			[98]
Mitrac Energy Saver	Bombardier	EDLC	LRV Mannheim, Germany	Energy saving. Catenary free operation	2003-2007	[26,60,98,136,137,140,140–144]
			Heidelberg, Germany		2009	[145]
	SAFT	Li-ion	Seattle, WA, USA (Trio)	Catenary free operation	2016	[138]
APB system	Alstom-SAFT	NiMH	Nice, France (Citadis)	Catenary free operation	2004 (test), 2007	[26,60,98,129,130,136,138,140–142,146]
	Alstom	FES	Rotterdam, Netherlands (Citadis)	Energy saving. Catenary free operation	2004	[26,136,138,140,141,146]

STEEM (project)	Alstom	EDL C	LRV T3 Paris, France (Citadis)	Energy saving. Catenary free operation	2009-2010	[26,60,98,130,136,138,140,141]
APS	Alstom	EDL C	Bordeaux, France (Citadis)	Catenary free operation	2003	[130,138]
			Reims, France (Citadis)	Catenary free operation	2011	[130,138]
			Orléans, France (Citadis)	Catenary free operation	2012	[130,138]
			Angers, France (Citadis)	Catenary free operation	2009	[130,138]
			Brasilia, Brazil			[130]
			Tours, France (Citadis)	Catenary free operation	2013	[130,138]
			Dubai, United Arab Emirates (Citadis)	Catenary free operation	2014	[130,138]
			Cuenca, Ecuador (Citadis)	Catenary free operation	2016	[138]
			Rio de Janeiro, Brazil (Citadis)	Catenary free operation	2016	[138]
			Lusail, Qatar (Citadis)	Catenary free operation	2018	[138]
			Sydney, Australia (Citadis)	Catenary free operation	2019	[138]
	Alstom	EDL C	Kaohsiung, Taiwan (Citadis 305)		2019	[60]
Sitras ESM (HES)	Siemens	EDL C+N iMH	Lisbon, Portugal (Combino-plus)	Energy saving	2008	[98,129,133,138,140-142,147]
			Doha, Qatar (Avenio)	Catenary free operation	2016	[133,138]
Sitras MES	Siemens	EDL C	Innsbruck, Austria	Energy saving	2011	[60,136,137,140,147]
			Guangzhou, China		2014	[60]
Gigacell	Kawasaki Heavy Industry	NiMH	LRV Harima, Japón (2km test)		2007	[26]
			Sapporo, Japan (SWIMO)	Energy saving. Catenary free operation	2007	[60,98,136,138,141]
		Li-ion	Sapporo, Japan (Hi-tram)	Catenary free operation	2007	[26,141]
	Toshiba	EDL C	Nagoya, Japan	Support mechanical braking	2005	[26,60,141]
SCiB		Li-ion	Tokyo, Japan	Emergency-running	2016	[131,132]
			West Japan (Twilight Express Mizukaze)	Catenary free operation	2017	

			Central Japan (N700S Shinkansen)	Emergency-running		
	Hitachi	Li-ion	Osaka, Japan		2007	[148]
		Li-ion	RTRI, Japan (Lithey-Tramy)		2003	[141]
LFX-300	Kinki Shayro	Li-ion	Charlotte, NC, USA (ameriTRAM)	Energy saving. Catenary free operation	2010	[138,149]
NeoSee	Adetel	EDL C	Nice, France	Catenary free operation		[134,150]
		+Li-ion	Kaohsiung, Taiwan	Catenary free operation		
	CNR Changchun	EDL C	Shenyang, China	Catenary free operation	2013	[138]
	ABB	Li-ion	Dallas, TX, USA (Liberty)	Catenary free operation	2015	[138]
	Stadler	Li-ion	Munich, Germany (Variobahn)	Catenary free operation		[138]
		EDL C	Rhine-Neckar, Germany (Variobahn)		2012	[60]
	AnsaldoBreda	EDL C	Florence, Italy (SIRIO)	Catenary free operation	2012	[138]
			Bergamo, Italy (SIRIO)			
	JR Hokkaido	Li-ion	Japan		2007	[60]
	Brookville Equipment	Li-ion	Oklahoma City, OK, USA		2018	[60]
	Vivarail	Li-ion	Wales, UK		2018	[60]
	CNR Changchun/Voith	EDL C	Shenyang, China		2013	[60]
	American Maglev/Maxwell	EDL C	Portland, OR, USA (SD660)		2012	[60]
	Vossloh	EDL C	Rostock, Germany (Tramlink 6N2)		2014	[60]
	Pesa	EDL C	Wroclaw, Poland (Twist tram)		2015	[60]

2.4.2 Wayside ESS (WESS)

An ESS installed on board a train can store only the train's own regenerated energy. Conversely, by installing the device wayside, several trains can make use of the regenerated energy flow. A representation is shown in Figure 1. The ESS captures and stores the braking energy that cannot

be immediately used by other trains upon its generation. Later, the stored energy can be returned to the system to power trains when there is demand [20]. Moreover, they do not add weight or a size constraint to the trains, a failure or maintenance does not affect the operation [68] and can be fixed without interrupting service.

Typically, these ESSs are installed in substations or locations subject to frequent voltage drops, such as stations. However, this installation approach results in higher transmission losses due to the increased distances between the trains and the device. Several studies can be found trying to minimize those losses by finding the optimal location of the ESS alongside the line [50,51,151–154].

Table 11 shows the real applications of WESS in RS up to date found in prior studies while

Table 12 includes the technical characteristics of those devices. All the installations use FESS, Li-ion or EDLC with the exception of one NiMH battery. It is important to highlight the case of Siemens, which initially attempted to enter the market with a FESS but ultimately shifted their focus to developing EDLCs (Sitras SES) installed in at least 11 cities. Additionally, it is worth noting that this, along with some other examples such as the ACE2 or SA2VE projects in Madrid (Spain), were just test projects that are no longer operational.

Table 11: Development and application of stationary ESSs in railway systems

EXAMPLES OF WESS IN RS						
COMERCIAL NAME	MANUFACTURER	ESS	PLACE	PURPOSE	YEAR	REFERENCES
	Siemens	FESS	Cologne, Germany		2000	[155,156]
Sitras SES	Siemens/Maxwell	EDLC	Cologne, Germany	Energy saving, voltage stabilization	2001	[26,62,71,136,137,147,157–160]
			Madrid, Spain	Voltage stabilization	2002	
			Beijing, China	Energy saving	2007	
			Portland, OR, USA	Energy saving	2015	
			Bochum, Germany		2004	
			Rotterdam, Netherlands	Energy saving	2010	
			Toronto, Canada	Energy saving	2011	

			Nuremberg, Germany	Energy saving	2007	
			Dresden, Germany		2002	
			Tacoma, WA, USA	Voltage stabilization	2013	[41]
			Sacramento, CA, USA	Energy saving		[61]
	Woojin Industrial Systems Co	EDLC	New York, USA			[157]
			Seoul, Korea		2008, 2009, 2011	[157,161,162]
			Daejeon, Korea		2010	[162,163]
			Daegu, Korea		2013	[162]
			Boston, USA		2015	
			KTX, Korea		2009	
EnerGstor	Bombardier	EDLC	Kingston, Canada			[62,137,157]
Powerbridge	Piller	FESS	Hanover, Germany	Energy saving	2004	[62,136,157]
			Rennes, France	Energy saving	2010	[62,157]
			Bielefeld, Germany	Energy saving	2012	[62,164]
			Hamburg, Germany		2006	[62]
			Paris, France		2007	[62]
			Freiburg, Germany	Energy saving	2013	[62,165]
			Zürich, Switzerland		2009	[62,166]
	RTRI	Lead-acid	Japan	Suppress energy demand	1910	[26,29]
	RTRI	Lead-acid	Japan	Suppress voltage drop	1980	[26,29,167]
Enviline ESS / Envistor	Envitech Energy (ABB group)	Li-ion (Saft Inten sium max 20P)	Philadelphia, USA	Energy saving	2012	[38–40,61,71,136,168–171]
		EDLC	Melbourne, Australia			[62,71,168,169]
			Warsaw, Poland	Energy saving	2016	
NeoGreen Power ES	Adetel	EDLC	Lyon, France	Energy saving	2011	[150]
			Tours, France	Energy saving	2014	
NeoStab			St.Gervais-Vallorcine, France	Voltage stabilization	2015	
Capapost	Meidensha Corporation	EDLC	Hong-Kong		2016	[71,161,172]
			Seibu, Tokyo, Japan	Energy saving	2007	[26,29,46,136,137,167]

Vycon REGEN	Vycon (Calnetix)	FESS	Los Angeles, CA, USA	Energy saving, Peak Power Reduction	2014	[43,61,71,136,173-176]
Powerbridge	Piller	FESS	Hanover, Germany	energy saving	2004	[136,157]
			Zurich, Switzerland		2009	[166]
			Rennes, France		2010	[157]
			Bielefeld, Germany	energy efficiency	2012	[164]
			Freiburg, Germany	energy efficiency	2013	[165]
	Rosseta Technik GmbH	FESS	Dessau, Germany		2006	[62,177]
			Zwickau, Germany		2006	[62,177]
			Postdam, Germany			[177]
			Halle, Germany			[177]
GTR system	Kinetic Traction Systems (Ureco Power Technology + Pentadyne Power Corporation)	FESS	Paris, France	Maintenance support		[157,178-180]
			New York, USA	Voltage support	2002	[28,61,71,136,157,178-180]
			Lyon, France	Energy saving	2003-2004	[26,71,157,178-181]
			London, UK	Voltage support	2000	[28,71,136,157,158,178-180]
BeCHOP	Hitachi	Li-ion	Kobe, Japan	Energy saving	2005 & 2007	[26,29,71,136,148,167,182]
			Seoul, Korea		2011	[182]
			Tokyo, Japan	Energy saving	2013, 2014	[44,45,55,182]
			Osaka, Japan		2014	[182]
			Horinouchi, Yokosuka, Japan		2014	
			Hong Kong		2016	[183]
Gigacell Battery Power System (BPS)	Kawasaki	NiMH	New York, USA	Voltage drop, Emergency supply	2010	[61,71,136,184]
			Osaka, Japan	Energy saving	2011, 2013	[136,157,167,167,185]
			Washington, USA		2012	[157,185]
			Tokyo, Japan	Energy saving, Emergency supply	2013, 2014	
			Sapporo, Japan		2013	
ACE2 (project)		FESS	Madrid, Spain		2003	[26,186]

			Boston, USA				620	2.44	[162]
			KTX, Korea				55000	11.68	[162]
EnerGstor	Bombardier	EDLC		0.65	500		600/ 750	1	[62, 157]
Powerbridge	Piller	FESS	Germany	1	1500	16		4.6	[164]
Battery post (1st generation)	RTRI	Lead-acid	Kobe, Japan		1000				[26]
Enviline ESS / Envistor	Envitech Energy (ABB group)	Li-ion (Saft Intensium max 20P)	Philadelphia, USA	1.5	1600		660	420	[38, 62]
	Envitech Energy (ABB group)	EDLC	Melbourne, Australia	2.5	1680		1500	6.66	[62, 171]
			Warsaw, Poland	3.3			750	11.1	
NeoGreen Power ES	Adetel	EDLC	Lyon, France	1			750	3	[62, 150, 157]
			Tours, France	0.66			750	2	
NeoStab			St.-Gervais Vallorcine				850		[62]
Capapost	Meidensha Corporation	EDLC	Hong-Kong	3			1500		[62]
			Seibu, Tokyo, Japan	2.56	4000		1500	6.875	[26, 29,62 ,167]
Vycon REGEN	Vycon (Calnetix)	FESS	Los Angeles, CA, USA	2		15	750	8.33	[43, 62, 174]
Powerbridge	Piller	FESS	Hanover, Germany	1	1500	16	600	4.6	[62]
			Hamburg, Germany				750		[62]
			Paris, France				750		[62]
			Zurich, Switzerland				600		[62]
			Rennes, France				750		[62]
			Bielefeld, Germany				750		[62]
			Freiburg, Germany	1	1500		750	7.3	[62, 165]
	Rosseta Technik GmbH	FESS	Dessau, Germany	0.5	1000		600/ 750	6	[62, 177]
GTR system	Kinetic Traction Systems (Urenco Power Technology + Pentadyne Power Corporation)	FESS	London, UK	0.3			630	3	[26, 62, 158, 180]
			New York, USA	1					[62, 180]
			Lyon, France	0.6			750		[62, 180]
			Paris, France				750		[62]
BeCHOP	Hitachi	Li-ion	Kobe, Japan	1		20	1500	37.4	[29, 62, 167,

								182, 187]	
				0.5/1 /2	300/600/ 1200		1500	[187]	
			Seoul, Korea	1			1500	[62, 182]	
			Osaka, Japan	0.1			750	[62, 182]	
			Okegawa, Japan	2	1200		1500	[44, 62, 182]	
			Horinouchi, Japan	2.145			1500	[62, 182]	
			Hong-Kong				750	[62]	
Gigacell Battery Power System (BPS)	Kawasaki	NiMH	New York, USA	1.9			670	367	[62, 185]
			Osaka, Japan	5.6			750	205	[29, 62, 167, 185]
			Washington DC, USA				750	385	[62, 185]
			Tokyo, Japan					203	[62, 185]
			Sapporo, Japan				750	204	[62, 185]
		FESS	Keihin, Japan	3				25	[26, 29, 167]
		Li-ion	Nagoya, Japan	0.5				18.7	[29, 167]
		Li-ion	Kagoshima, Japan	0.25				18.1	[29, 167]
ACE2 (project)		FESS	Madrid, Spain	0.35			3000	55	[26, 186]
SA2VE (project)									

3. Analysis

Regardless of the specific requirements that need to be met with an ESS, it is not possible to find a single technology that satisfies all the criteria and compromises are needed. Ultimately, it is the specific application that determines the most suitable device for implementation [188].

Having provided descriptions of various technologies, filtered out those incompatible with railways, explained the defining properties of these technologies, and reviewed existing devices in real-world applications, the focus can now narrow down to five devices that appear to be the most appropriate for addressing the challenge of storing the regenerative energy of the electric

braking trains. Three of them are, as seen before, used in this type of applications: Li-ion battery, EDLC, and FESS. Furthermore, the analysis will include SMES due to its properties suitable for operation in RS, while the VRB will also be considered as it represents a different type of storage with promising features.

First, Table 13 incorporates the technical characteristics found in prior studies. Subsequently, various graphical analyses and comparisons are conducted to evaluate the different ESSs. Lastly, in section 4, the most suitable technology for optimizing the harnessing of regenerative energy in a railway system will be identified.

Table 13: Technical characteristics of ESSs in academic articles

	Power rating (MW)	Storage capacity (kWh)	Response time	Re-charge time	Dis-charge time	Ef-ficiency	Storage duration		Specific Energy and Power		Energy and Power Density		Lifetime and cycle life		Ref	
							Self dis-charge per day (%)	Suit-able stor-age du-ration	Wh/kg	W/kg	Wh/l	W/l	years	cycles		
Li-ion	0-0.1				min-h	85-90	0.1-0.3	min-days	75-200	150-315	200-500		5-15	1000-10000+	[104, 189]	
	0-0.1		<s		min-h	65-75	0.1-0.3				200-400	1300-10000	5-100	600-1200	[91]	
						90-100			80-150						[190]	
						70-100	0.03-0.33		30-300	8-2000	94-500	56.80-800	2-20	250-10000	[105]	
			20ms-s	min-h	min-h		0.1-0.3		100-250	230-340	250-620	1300-10000	8-15	500-6000	[102]	
			<s		h	85-98			60-200		200-400	1300-10000	5-15	500-10 ⁵	[84]	
						70-85			100-200	12-2000				500-2000	[99]	
			1s			86							10	3500	[191]	
		1-100				0.15-1h	75-90						5-15	4000-100000	[192]	
		0.1-50					78-88	1-5		80-150	245-500			14-16	1500-3500	[193]
							70-85			100-200	360				500-2000	[79]
		0.1-5	5-10	s	min-h	min-h	90			125-250		140-630		8-15		[194]
		0.05-100		<s		1min-8h	85-95	0.1-0.3				200-400	1300-10000			[195]

	<100	250-2500				<=1h	<=90						<=15		[89]	
	0.05-100	250-2500	ms		min-1h	85-95	0.15-0.3		120-230	150-2000			20-25	1000-10000	[196]	
	0.01				min-h	85-95	0.1-0.3	min-days	150-350	50-2000			5-15	1500-4500	[197]	
	0.1		ms		min-h	85-90	0.1-0.3		75-200				5-15	4500	[112]	
	5				15 min-h	90							15		[103]	
FESS	0-0.25				ms-15min	85-95	100	s-min	10-30	400-1500	20-80	1000-2000	aprox 15	20000+	[104, 189]	
	0-0.25		<s		s-h	80-90	100				20-80	5000	15-20		[91]	
						90			30-100						[190]	
	0.001-10					70-96	24-100		5-200	400-30000	0.25-424	40-2000	15-20	10 ³ -10 ⁴	[105]	
			<4ms-s	<15min	15s-15min		20-100		5-130	400-1600	20-80	5000	>20	10 ⁷	[102]	
			<s		s	80-90			5-30		20-80	5000	15-20	2·10 ⁵ -10 ⁶	[84]	
			0.25s			86							>20	2·10 ⁵	[191]	
						92-97			10-50	1000-5000	20-80	1000-2500	20	8·10 ⁵ -10 ⁵	[136]	
	0.4-20					80-95							15-20		[192]	
	0.1-20					85	100		5-100	11900			20	10 ⁵ -10 ⁷	[193]	
	<10					90								10 ⁶	[198]	
	0.5-1					<5min									[199]	
	0.01-10	1-25	s	15min	s-min	>85							20	5·10 ⁴ -10 ⁴	[194]	
	0.001-20		<s		s-min	70-95	1.3-100					20-80	5000		2·10 ⁴ -10 ⁴	[195]
	<=20	<=10 ⁴	<=10ms		<=1h	<=85								<=20		[89]
	0.01-0.25	25-5000	s		s-15min	90-95	1.3-100		5-80	700-12000			15-20	2·10 ⁴ -10 ⁴	[196]	
0.005-90	0.005-200	12min	min		80-95							20		[200]		
0.25				ms-15min	93-95	100	s-min	5-100	1000			15-20	2·10 ⁴ -10 ⁴	[197]		
0.25		very fast	min	ms-15min	93-95	100		10-30				appro x. 15	>1000	[112]		
0.75-1.65				15s-15min	93							20		[103]		
EDLC	0-0.3				ms-60m	90-95	20-40	s-h	2.5-15	500-5000	10-30		20+	10000	[104, 189]	
	0-0.3		<s		ms-60m	85-98	20-40				10-20	4000	4-12	104-105	[91]	
						85-98			0.1-5						[190]	
						65-99	0.46-40		0.07-85.60	5.44-10 ⁵	1-35	15-4500	5-20	10 ³ -10 ⁵	[105]	
			8ms	s-min	ms-1h		2-40		0.1-15	0.1-10	10-20	4000	>20	5·10 ⁵	[102]	

											120000				
		<s		s	85-98			1-15		10-20	40000-120000	4-12	10 ⁴ -10 ⁵	[84]	
					95			<50	4000				>50000	[99]	
		16ms			92							16	10 ⁶	[191]	
					90-98			2.5-15	500-5000	150-500	400-1000	5-15	2 ⁴ -10 ⁴	[48]	
0-10				ms-s	75-98							8-20+	200-1000	[192]	
0.05-0.25								2-69	800-23600					[193]	
<10					90								10 ⁷	[198]	
					95			<50	4000				>50000	[79]	
<0.25				<1min										[199]	
0.1-10		s	s	s	90								50000	[194]	
0.01-1		<s		ms-min	80-95	20-40				10-20	40000-120000		10 ⁴ -10 ⁵	[195]	
<=1	100-500	<=10ms		<=1min	<=95							<=40		[89]	
0.01-0.3		ms		ms-min	85-95	10-40		0.05-15	10-10e5			25-30	10 ⁵ -50000	[196]	
<1	0.001-1	ms	s		>95							>10		[200]	
0.3				ms-60min	85-95	20-40	s-h	2.5-50	800-23500			10-20	>10000	[197]	
0.3		very fast	s	ms-60min	90-95	20-40		2.5-15				>20	>10000	[112]	
10				<=30s	90								<50000	[103]	
SMES	0.1-10			ms-8s	95-98	10-15	min-h	0.5-5	500-2000	0.2-2.5	1000-4000	20+	10 ⁵ +	[104, 189]	
	0.1-10		<s	ms-8s	75-80	10-15				6	2600			[91]	
					97-98									[190]	
	0.01-200				80-99	1-15		0.27-75	500-15000	0.20-13.80	300-4000	20-30	10 ⁴ -10 ⁵	[105]	
			<100ms		ms-8s		10-15		10-75	2600	0.006	20		10 ⁵ -10 ⁶	[102]
			<s		s	75-80					6	2600			[84]
	0.1-10				ms-s	90-97+							20-30		[192]
						80-95	10-15						20	10 ⁵ -10 ⁶	[193]
	<100					95								10 ⁷	[198]
	0.01-10				<1min										[199]
	0.1-10+				1-100s	>90								50000	[194]
	0.1-1		<s		ms-s	80-95	10-15				aprox 6	aprox 2600		10 ⁵	[195]

	<=10	1000-3000	<=10ms		<=1min	<=95						<=40		[89]		
	0.01-10		ms		ms-s	90-97	10-15		0.5-5	500-2000		20-30	20000-10 ⁵	[196]		
	0.170-100	0.110-27	ms	s		95						30		[200]		
	0.1-10				ms-8s	95-98	10-15	min-h	0.5-5	500-2000		15-20	>10 ⁵	[197]		
	0.1-10		very fast	min	ms-8s	95-98	10-15		0.5-5			>20	>10000	[112]		
	1-3				1-3s	90							>30000	[103]		
VRB	0.03-3				s-10h		small	h-months	10-30		16-33	5-10	12000+	[104, 189]		
	0.03-3		s		s-10h	60-75	small				20-70	0.5-2	5-20	>10000	[91]	
						85								[190]		
	0-20					60-88			10-50	31.30-166	10-33	2.50-33.42	2-20	800-16000	[105]	
			<1ms	min	s-10h		0-10		75			20-35	0.5-2	10-20	13000	[102]
			s		h	60-75				15-50		20-70	0.5-2	5-20	>10000	[84]
	<3	500-5000				70-85						16-33	5-10	>12000	[199]	
	0.05-10				2-8h	60-80							5-15		[194]	
	<=50	<=250000	<=10min		<=8h	<=80							<=10		[89]	
	0.01-10	4000-40000	ms		5-10h	60-75	small			25-35			10-20	>12000	[196]	
	0.03-3				s-10h	65-85	small	h-months	10-35	166			5-10	10000-13000	[197]	
	4				4-8h	63-80							10		[103]	
					80	Negligible			25	80-150			>16000	[79]		

3.1 Efficiency and lifetime

Figure 4 illustrates the efficiencies derived from the data presented in Table 13 for the five ESSs chosen. EDLC and SMES show efficiencies exceeding 90%, while FESS stays at 90%. However, both batteries exhibit relatively lower efficiencies, particularly VRB.

Figure 5 shows a comparison of the lifetime of the different technologies. The pre-selected technologies for the problem at hand seem to be in the average lifetime, with the ones for the Li-ion and VRB batteries being the shortest.

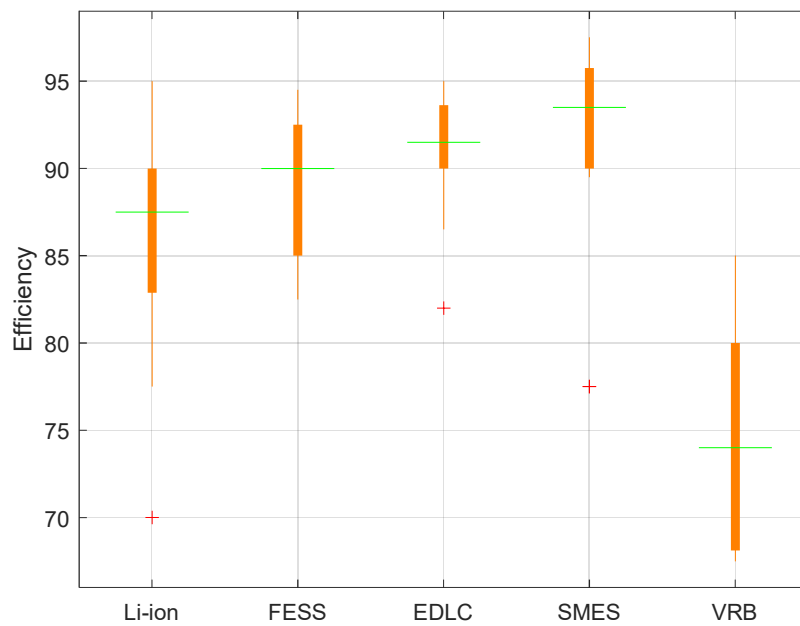

Figure 4: Efficiency of ESS. (Data from Table 13)

While it is useful to have an idea of the years of lifetime to predict how long the investment will last, it is often also necessary to look at the lifetime in operating cycles to make the technologies comparable.

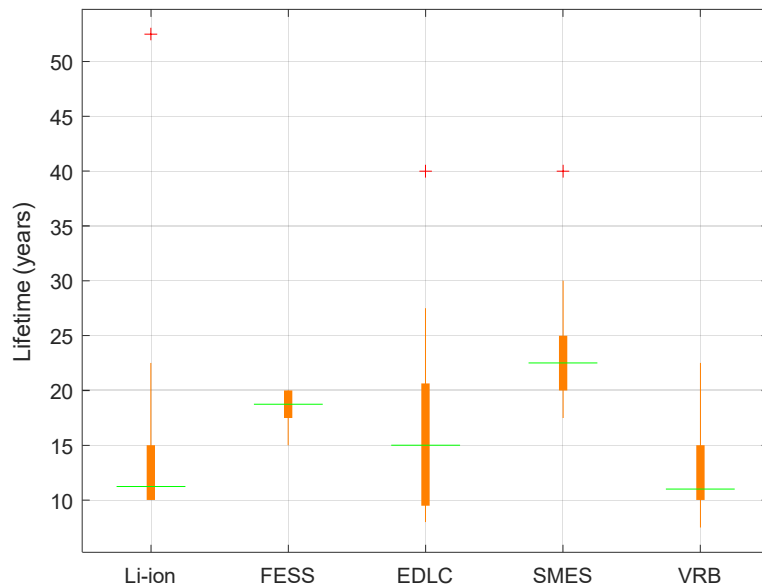

Figure 5: ESSs lifetime in years. (Data from Table 13)

Both, efficiency and lifetime, influence the final cost of an ESS. Low efficiencies imply that only a portion of the storage energy is actually available while the lifetime tells us how often the

device should be replaced. A representation of the different technologies as a function of these both parameters is shown in Figure 6 and the comparison is made now with the lifetime in charge and discharge cycles instead of years.

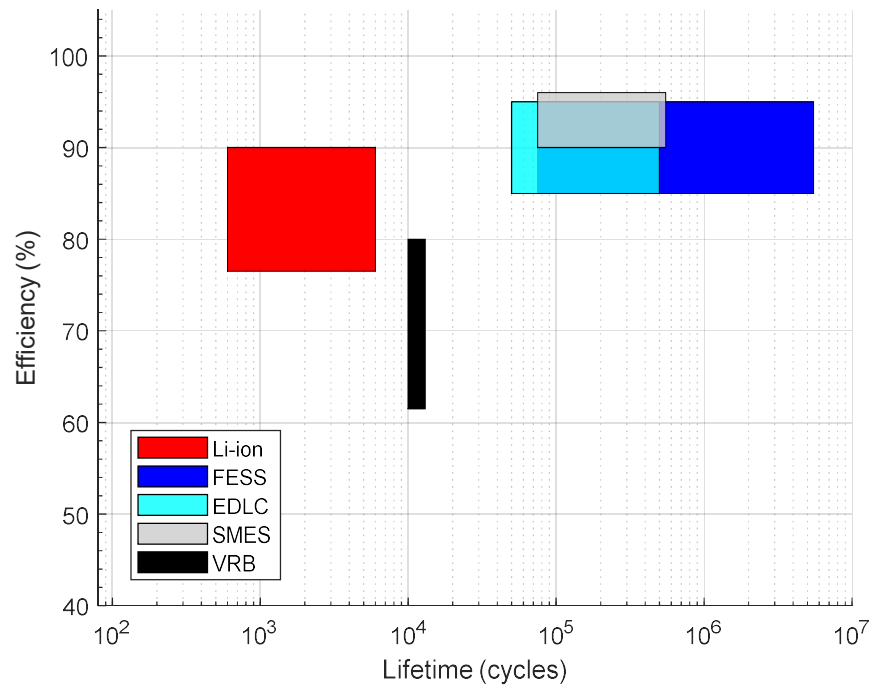

Figure 6: Efficiency and lifetime of some ESS. (Data from Table 13)

It can be seen that FESS, EDLC and SMES have long lifetimes. In the case of FESS, being a mechanical ESS, the lifetime is mostly dictated by the durability of the mechanical components [104]. However, BESS show a shorter life as well as a lower efficiency especially the VRB. The replacement cost is vital for electrochemical ESSs [90]. They have a limited lifetime due to deterioration over time caused by the degradation of chemical elements and electrolytes. Also, since SMES devices do not have any moving parts or chemical reactions, they have excellent cycle capabilities [201].

The devices with the best ratio efficiency-lifetime are, again, EDLCs and FESSs.

3.2 Maturity

Another characteristic for the comparison and assessment of the different technologies is the technical maturity. Following the criteria in [104] it can be classified into three categories:

- Mature technologies: LA batteries are the most established possibility since they have been used for over 100 years.
- Developed technologies: Li-ion, FESS, EDLC and VRB are technically developed and commercially available but still need research to improve reliability.
- Developing technologies: FC are one of those technologies still in need of more research.

Although the 5 technologies under study fall under the classification of developed devices according to [104], it is important to differentiate that, in the case of railway applications, SMES and VRB could be considered as developing technologies, since no real applications have been found.

3.3 Energy and Power Density

When evaluating storage technologies for railway applications, energy and power density are important characteristics. This is particularly important when it comes to on board ESS, where, as has been seen previously, both weight and space are crucial.

A Ragone plot [202]] is commonly used to illustrate performance in terms of the ratio of mass to energy and power when comparing storage technologies. Both axes are logarithmic and each area represents a particular ESS.

For a given energy capacity, the higher the power and energy density the smaller the device. In Figure 7, the smaller ESSs are in the upper right corner while those with a higher volume can be found in the lower left corner. VRB stands out as having a very low power density, while EDLC would be the one that could provide more. Li-ion battery as expected, offers a great energy and power density. It makes it the most suitable, according to these parameters, to be used on board trains.

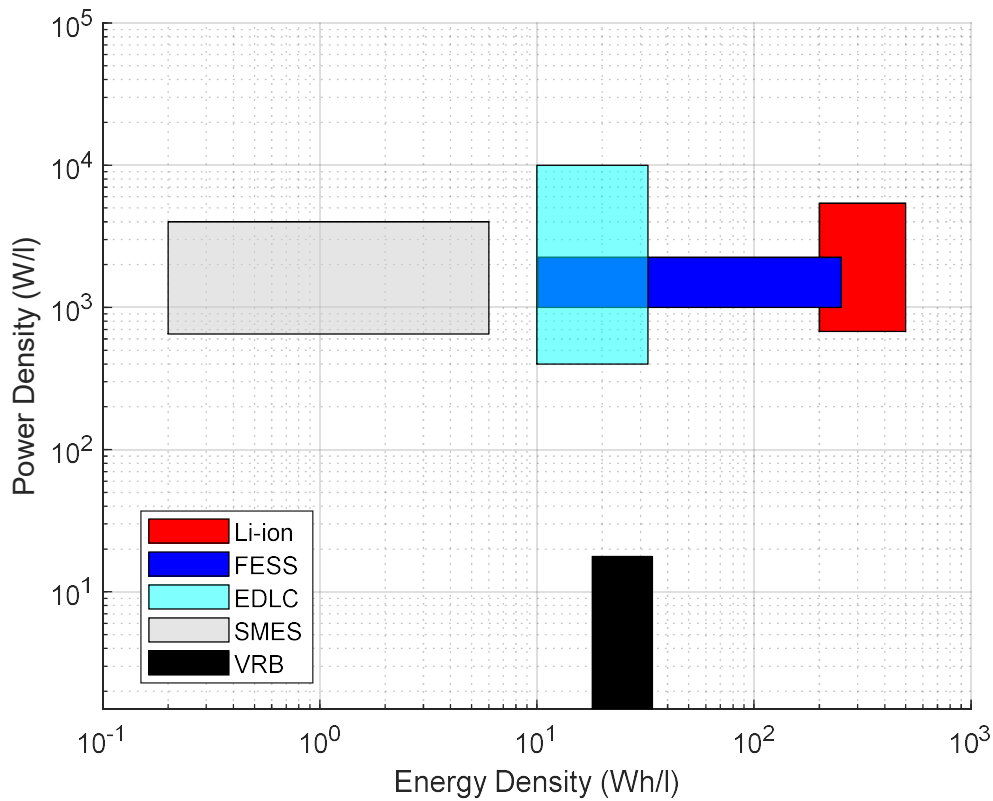

Figure 7: Comparison of EESs depending on power and energy density. (Data from Table 13)

3.4 Specific Energy and Power

Similarly to the previous point, devices with higher power and specific energy are lighter in weight. In Figure 8, the more lightweight EESs are located in the upper-right area. It can be seen how SMES and EDLC have high specific power but low energy, so they are suitable for applications where high power (current) must be supplied. FESS is in the mid-range of both. VRB has similar specific energy but lower specific power. Conversely, Li-ion batteries excel in both magnitudes making them the lightest and optimal choice for on board applications.

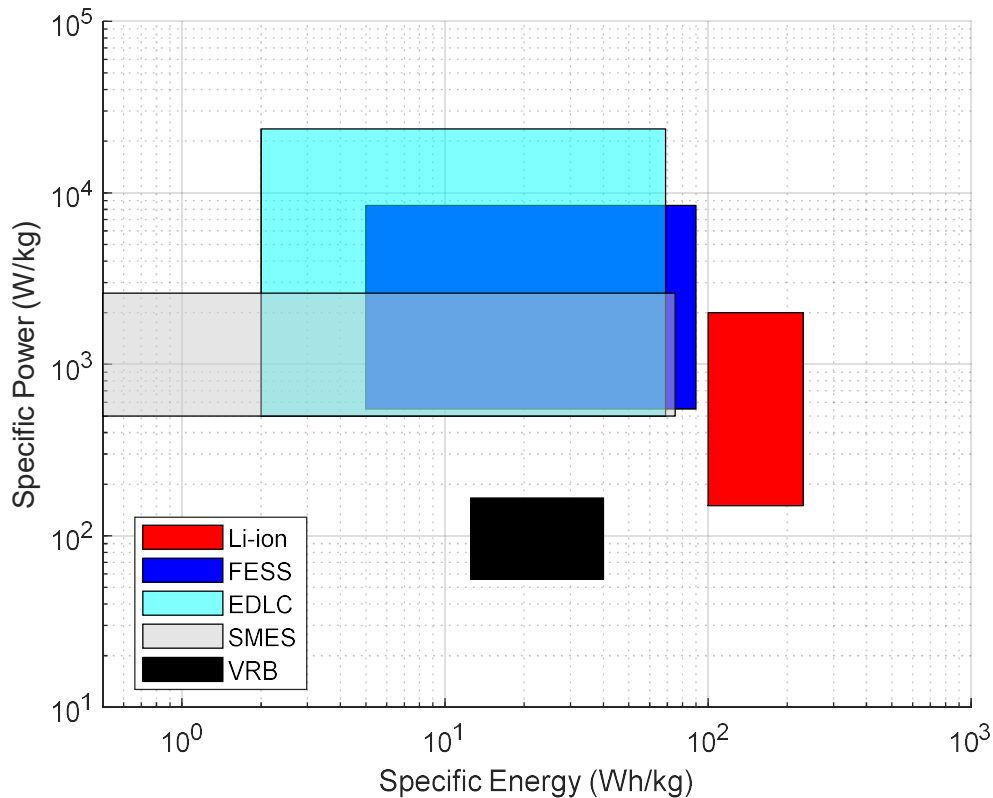

Figure 8: Comparison of EESs depending on specific energy and power. (Data from Table 13)

3.5 Discharge Time and Power

Considering the continuous braking and starting of trains at the station, not only the power delivery capability of the ESS is important, but also the discharge time. A classification of different technologies according to both parameters is shown Figure 9. Additionally, the figure shows the three suitable applications for ESSs depending on these factors [93]:

- Energy management: In these cases, the energy needs to be stored and released in long periods of time.
- Bridging power: Stored energy in these applications is used, for example, for emergency backup to ensure service continuity.
- Power quality and uninterruptible power supply (UPS). These are the fastest ESSs when charging and discharging so the devices in this set are the most suitable for working as a WESS or on board trains.

Four of the devices previously selected are found in the desired area; FESS, Li-ion, EDLCs and SMES. VRB however, seems to be more appropriate for energy management applications.

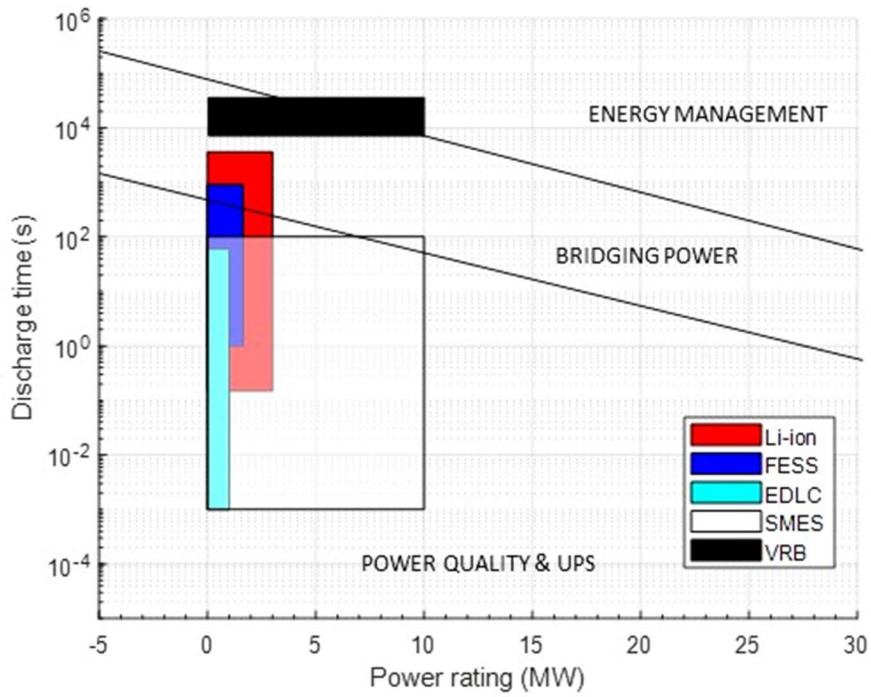

Figure 9: Power and discharge time. (Data from Table 13)

3.6 Total capital cost

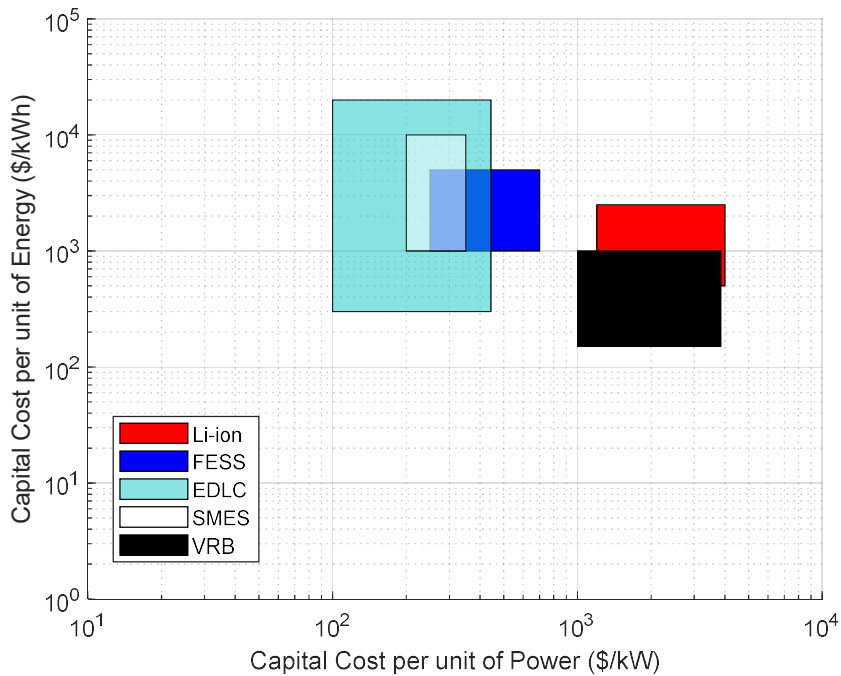

Figure 10: Power cost vs energy cost of different ESSs. (Data from Table 14)

The capital cost (TCC) significantly influences the extent of commercial implementation of ESSs. In general terms, the capital cost is measured in terms of power cost (\$/kW) and energy cost (\$/kWh). Figure 10 reveals that FESS, EDLC, and SMES technologies have lower power costs compared to their energy costs. This indicates that these systems are better suited for applications requiring high power for shorter durations as expected [86].

Different cost models are found in existing research. Most of them identify the three main components of an ESS seen in Figure 3 and calculate the *TCC* following Equation 3. C_{PCS} , and C_{SU} represent the unitary costs of the power conversion system (\$/kW) and the storage unit (\$/kWh) respectively, C_{BOP} (\$/kW) the BOP costs and h is the charging/discharging time. By employing this approach, the cost of the power conversion system and the storage unit are separated, allowing for a more clear estimation of the single contributions of each component in TCC calculations [197].

$$TCC = C_{PCS} + C_{BOP} + C_{SU} \cdot h \text{ (\$/KW)}$$

Equation 3

Figure 11 shows the TCC of the ESSs per unit of power. Bear in mind that the costs are represented for the typical storage size of each system, which may vary among different technologies. Considering the discharge time of the device, the TCC can be calculated per unit of power or storage capacity (\$/kWh).

However, [68], [107] and [104] consider the cycle of life in the TCC by calculating the costs per cycle due to the frequent charge–discharge sequences when using ESSs in urban rails. From its representation in Figure 12 it is seen that both batteries, Li-ion and VRB, are the most expensive choices when considering their cycle life.

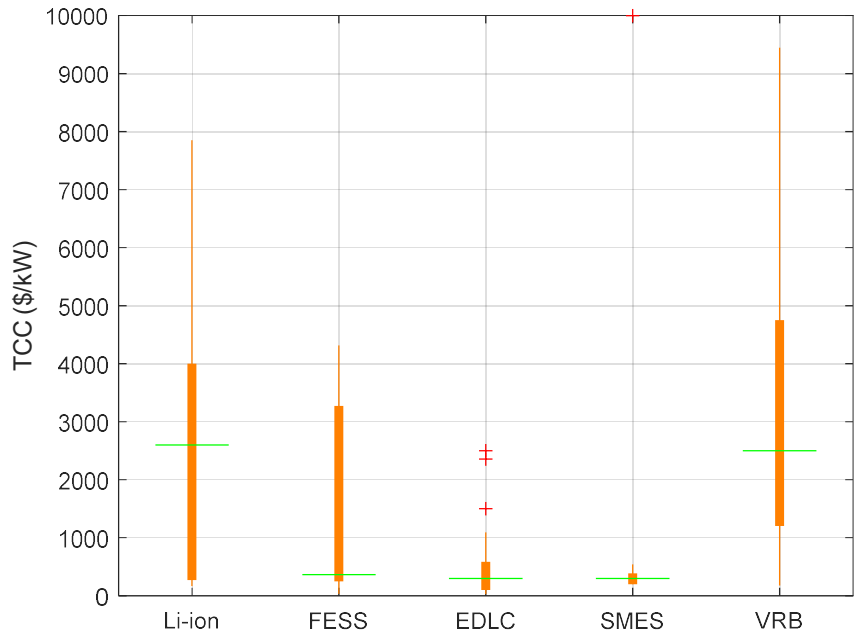

Figure 11: TCC of different ESSs. (Data from Table 14)

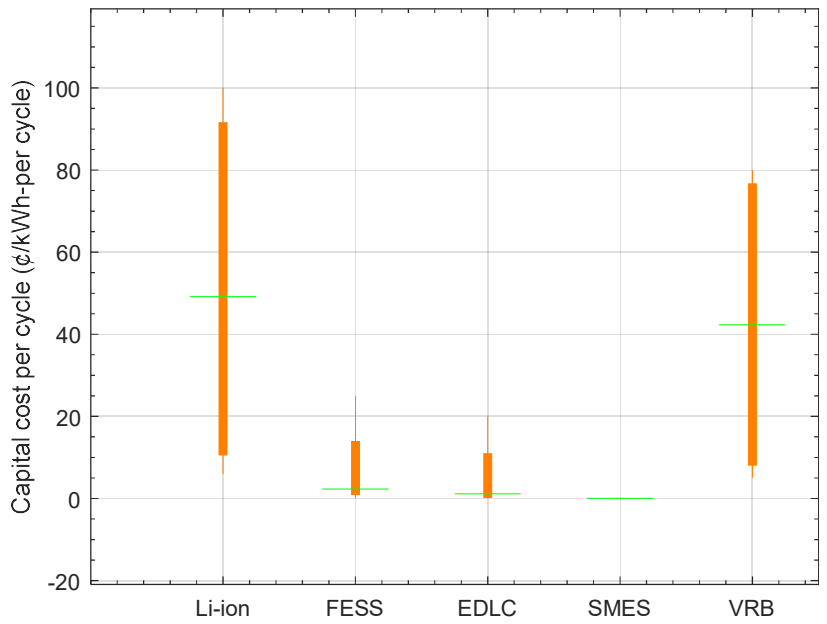

Figure 12: TCC per cycle for different ESSs. (Data from Table 14)

While some studies are focused on the TCC [90,96,112,203] others consider important to include some additional costs like replacement or maintenance costs [69] and calculate the life cycle

cost (LCC) to compare technologies. The relationship between these magnitudes is represented in Figure 13.

The LCC calculated in Equation 4 is usually presented in an annualised form [204], where C_{REP} represents the replacement cost, C_{EOL} is the disposal and recycling costs upon the ESS system's end-of-life, and C_{OM} is the total operation and maintenance (O&M) cost through the lifetime of the system. Variable O&M refers to the entirety of costs needed to operate the storage system over its economic lifespan, and these costs are adjusted in relation to the annual discharge of energy [191].

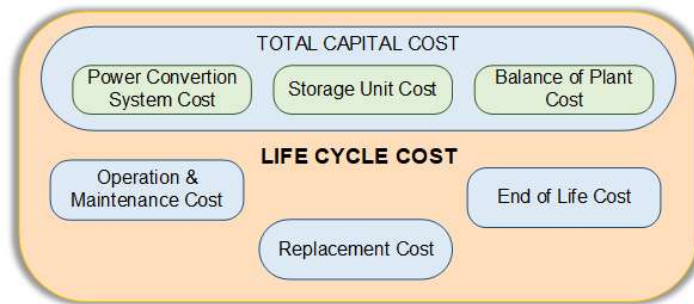

Figure 13: Overall life cycle cost structure of ESS.

$$LCC = TCC + C_{OM} + C_{REP} + C_{EOL}$$

Equation 4

Mostafa et al. in [204] compare the LCC of three of the main technologies applicable to RS. According to this study, EDLCs provide the most economical LCC compared to SMES and FESS technologies. It is important to take into account though, that they assume the same lifetime of EDLCs and the project (25 years). Therefore, the replacement cost for EDLCs technology is negligible. For this reason, the authors also carried out a sensitivity analysis in relation to the project's duration. As the project's lifespan extends, the LCC diminishes until it reaches the ESS end-of-life, where the LCC experiences a slight increase due to replacement costs.

Figure 10, Figure 11 and Figure 12, provide a visual representation of the magnitude scales and price ranges, enabling the comparison of costs across various technologies. Table 14 includes the numerical values found in prior studies. The disparity in costs among the studies is due to different assumptions regarding cycle life, efficiency, discharge duration, etc. For example, costs per cycle from reference [107] and [201] are divided by the round-trip efficiency. In general, the more mature the technology is, the lower the uncertainties in costs [90]. In addition to the great variability in the cost data found, it has been avoided referencing studies that purely cited others

without providing new information. Exceptions were made when the second reference added more data or the original was not accessible. Also, note that O&M costs data are particularly difficult to find.

Table 14: ESSs costs

	Capital cost				Cost per cycle		Operation and maintenance costs	
	\$/kWh	Reference	\$/kW	Reference	¢/kWh-Per cycle	Reference	\$/kW-year	Reference
Li-ion	900-1300	[205]	1200-4000	[104,189,196]	15-100	[104,189]	2-123	[90]
	600-2500	[104,189]	175-7850	[206]	6-83.33	[107]	10	[191]
	500-2500	[68]	175-4000	[105]				
	500-6200	[206]	150-250 €/kW	[190]				
	200-4000	[105]	4000-5000	[103]				
	223-323	[191]						
	400-2500	[196]						
FESS	400-800	[205]	250-350	[104,189]	3-25	[104,189]	5-6	[90]
	380-2500	[203]	250-25000	[192]	0.01-1.56	[107]	5.6	[191]
	1000-5000	[104,189,196]	3000-10000 (€/kW)	[190]				
	1000-14000	[192]	30.28-700	[105]				
	200-15000	[105]	600-2400	[191]				
			140-350 (€/kW)	[198]				
			100-300	[196]				
EDLC	20000	[205]	100-300	[104,189,196]	2-20	[104,189]	1-6	[90]
	250-350	[203]	100-2355	[206]	0.03-0.24	[107]	1	[191]
	300-2000	[104,189,196]	25-510	[192]				
	300-20000	[192,206]	200-1000 (€/kW)	[190]				
	100-94000	[105]	100-800	[105]				
	82000	[207]	240-400	[191]				
			300	[207]				
			70-400 (€/kW)	[198]				
			1500-2500	[103]				

SMES	1000-10000	[104,189,192,196]	200-300	[104,189]	0-0.1	[107]		
	500-2000	[207]	300	[207]				
	500-1080	[105]	200-350	[192,196]				
			350 (€/kW)	[190]				
			196-10000	[105]				
			200-500 (€/kW)	[198]				
			380-490	[103]				
VRB	150-1000	[104,189,192]	600-1500	[104]	5-80	[104,189]	70	[201]
	100-2000	[105]	175-9444	[105]	11.03-73.53	[201]	4-51	[90]
	435-952	[191]	1280 (€/kW)	[190]			10	[191]
	500-800	[196]	3000-4000	[194]				
			1400-3700	[196]				
			7000-8200	[103]				
			600-2500	[192]				

4. Discussion

The previous analysis with the properties of the technologies serves to visualize the most favourable devices based on one or two criteria and in a general way. The comparisons show, for example, that SMES has a great efficiency and would therefore be the ideal technology for certain applications (Figure 4). However, it has low energy density (Figure 7), which could then, make it unsuitable for others. Each figure provides a broad overview but does not consider all the specifics. It is important to bear in mind that there is no perfect technology for any application and that the relative importance of the criteria in decision-making varies based on the desired objective. In the context of RS, maximizing the utilization of regenerative energy is essential. Therefore, it is already stated that an ESS must demonstrate the capability to operate through numerous cycles per day and swiftly deal with the braking and starting of numerous trains throughout the day. Additionally, it should be capable of supplying high currents to outweigh voltage fluctuations in the network, while ensuring a long lifetime, high efficiency and minimum costs. Moreover, when it comes to on board ESSs, there is a need for compact dimensions, lightweight design, sufficient maturity, and reduced hazard.

Based on the findings from the analysis, the current state of VRB technology makes it unsuitable for its application in RS. Its limited maturity in this area, the necessity of additional heat emission mitigation equipment that increases its size and overall low efficiency, invalidate it for on board

operation. Moreover, its slow charge/discharge performance further reduces its suitability as a WESS choice.

The similar energy density (size) of Li-ion, FESS and EDLC make all three viable choices for on board applications. However, considering the operational characteristics of FESS involving a flywheel operating close to passengers, inclination towards either of the remaining two options is preferred when making implementation decisions. This preference line up with the current installations presented in Table 10. In particular, EDLC emerges as the more favourable option due to its superior efficiency and lower cost. Conversely, since Li-ion has the higher costs and lower efficiencies it could be dismissed as the choice for a WESS while considering including SMES in the decision due to its similarities to FESS and EDLC. However, when examining maturity, FESS and EDLC emerge as the remaining options. These findings align again with the observations in Table 11, which showcase the real-world applications of WESSs.

5. Conclusions

The work highlights the general imperative for energy savings, with a specific focus on the significant potential for savings offered by RS through the consumption of regenerative energy generated during electrical train braking. To optimize the utilization of this braking energy, the review looks into various techniques and introduces energy storage devices. By identifying these ESSs and providing a detailed description of their operation and characteristics, the work carries out an existing research review that includes accessible operational data and real-world applications in railway installations. Following an analysis of the properties of different technologies, EDLC and Li-ion are proposed as the most appropriate on board options, while EDLC and FESS are recommended for WESS applications.

Energy storage is a rapidly developing field, not only within railway research but also in other areas such as power generation, electric vehicles, and sustainable buildings. Therefore, it is key to consider that new technologies or significant improvements in existing ones may arise potentially displacing the current optimal solutions. In light of this, the analysis has incorporated SMES and VRB as two of the most promising options for working as WESS in the future.

References

- [1] Office for National Statistics (ONS), Worries about climate change, Great Britain - Office for National Statistics, (2022). <https://www.ons.gov.uk/peoplepopulationandcommunity/wellbeing/articles/worriesaboutclimatechangegreatbritain/septembertoctober2022> (accessed April 4, 2023).
- [2] J. Gázquez-Abad, J.F. Guerrero, J. Mondéjar-Jiménez, M. Rodríguez, How companies integrate environmental issues into their marketing strategies, *Environ. Eng. Manag. J.* 10 (2011) 1809–1820. <https://doi.org/10.30638/eemj.2011.244>.
- [3] S.G. Carroll, Imperiled rail sector calls for relief measures as energy prices soar, *Www.Euractiv.Com* (2022). <https://www.euractiv.com/section/railways/news/imperiled-rail-sector-calls-for-relief-measures-as-energy-prices-soar/> (accessed April 4, 2023).
- [4] IEA, UIC, Railway Handbook 2017 - Energy Consumption and CO2 Emissions, International Energy Agency and International Union of Railways, 2017. <https://www.iea.org/reports/railway-handbook-2017> (accessed August 30, 2023).
- [5] UIC, 1990-2030 Environment Strategy Reporting System. Methodology and Policy, UIC-Sustainable Development Department, 2016.
- [6] L. Ren, L. Fan, M. Zhou, Y. Guo, Y. Zhang, C.J. Boehlert, G. Quan, Magnesium application in railway rolling stocks: A new challenge and opportunity for lightweighting, *Int. J. Lightweight Mater. Manuf.* 1 (2018) 81–88. <https://doi.org/10.1016/j.ijlmm.2018.05.002>.
- [7] M. Peña-Alcaraz, A. Fernandez, A.P. Cucala, A. Ramos, R.R. Pecharromán, Optimal underground timetable design based on power flow for maximizing the use of regenerative-braking energy, *Proc. Inst. Mech. Eng. Part F J. Rail Rapid Transit* (2011). <http://pif.sagepub.com/content/early/2011/12/02/0954409711429411.abstract>.
- [8] A. Ramos, M.T. Peña, A. Fernández-Cardador, A.P. Cucala, Mathematical programming approach to underground timetabling problem for maximizing time synchronization, *CEPADE* (2008) 95.

- [9] M. Domínguez, A. Fernández, A.P. Cucala, P. Lukaszewicz, Optimal design of metro automatic train operation speed profiles for reducing energy consumption, *Proc. Inst. Mech. Eng. Part F J. Rail Rapid Transit* 225 (2011) 463–474.
- [10] C. Sicre, A.P. Cucala, A. Fernández, P. Lukaszewicz, Modeling and optimizing energy-efficient manual driving on high-speed lines, *IEEJ Trans. Electr. Electron. Eng.* 7 (2012) 633–640. <https://doi.org/10.1002/tee.21782>.
- [11] UIC, Process, Power, People. *Energy Efficiency for Railway Managers*, 2008.
- [12] Z. Qadir, A. Munir, T. Ashfaq, H.S. Munawar, M.A. Khan, K. Le, A prototype of an energy-efficient MAGLEV train: A step towards cleaner train transport, *Clean. Eng. Technol.* 4 (2021) 100217. <https://doi.org/10.1016/j.clet.2021.100217>.
- [13] UIC, CER, Rail Transport and Environment. *Facts & Figures*, 2016.
- [14] H.J. Chuang, Optimisation of inverter placement for mass rapid transit systems by immune algorithm, *IEE Proc. - Electr. Power Appl.* 152 (2005) 61–71. <https://doi.org/10.1049/ip-epa:20041143>.
- [15] H.J. Chuang, C.S. Chen, C.H. Lin, S.H. Chu, Optimization of inverter placement for mass rapid transit systems using genetic algorithm, in: 2005 IEEE PES Transm. Distrib. Conf. Exhib. Asia Pac., IEEE, Dalian, China, 2005. <http://search.ebscohost.com/login.aspx?direct=true&db=inh&AN=9262619> <=es&site=ehost-live.
- [16] Y.-S. Tzeng, R.-N. Wu, Electric Network Solutions of DC Transit Systems with Inverting Substations, *IEEE Trans. Veh. Technol.* 47 (1998) 1405.
- [17] L. Abrahamsson, L. Söder, Fast Estimation of Relations Between Aggregated Train Power System Data and Traffic Performance, *IEEE Trans. Veh. Technol.* 60 (2011) 16.
- [18] R. Kadhim, *Energy storage systems for railway applications – phase 1*, Rail Safety and Standards Board (RSSB), London, 2009.
- [19] G. Malavasi, P. Palleschi, S. Ricci, Driving and operation strategies for traction-energy saving in mass rapid transit systems, *Proc. Inst. Mech. Eng. Part F-J. Rail Rapid Transit* 225 (2011) 475–482.

- [20] W. Günselmann, Technologies for increased energy efficiency in railway systems, in: 2005 Eur. Conf. Power Electron. Appl., 2005: p. 10 pp.-P.10. <https://doi.org/10.1109/EPE.2005.219712>.
- [21] G. Kim, H. Lee, A Study on the Application of ESS on SeoulMetro line 2, in: 2009 Int. Conf. Inf. Multimed. Technol. Proc., 2009: pp. 38–42. <Go to ISI>://000276842100008.
- [22] H. Lee, E. Joung, G. Kim, C. An, A Study on the Effects of Energy Storage System, in: 2009 Int. Conf. Inf. Multimed. Technol., 2009: pp. 28–32. <https://doi.org/10.1109/ICIMT.2009.39>.
- [23] A. Adinolfi, R. Lamedica, C. Modesto, A. Prudenzi, S. Vimercati, Experimental assessment of energy saving due to trains regenerative braking in an electrified subway line, IEEE Trans. Power Deliv. 13 (1998) 1536–1542. <https://doi.org/10.1109/61.714859>.
- [24] L. Caputo, A. Rantzer, Control of Energy Storage Device for Rail Vehicles, Master Thesis, Lund University, 2000.
- [25] S. Sagareli, V. Gelman, Implementation of new technologies in traction power systems, in: Proc. 2004 AsmeIEEE Jt. Rail Conf., Amer Soc Mechanical Engineers, New York, 2004: pp. 141–146. <Go to ISI>://000221487500018.
- [26] T. Ratniyomchai, S. Hillmansén, P. Tricoli, Recent developments and applications of energy storage devices in electrified railways, IET Electr. Syst. Transp. 4 (2014) 9–20. <https://doi.org/10.1049/iet-est.2013.0031>.
- [27] D. Roch-Dupré, Á.J. López-López, R.R. Pecharrómán, A.P. Cucala, A. Fernández-Cardador, Analysis of the demand charge in DC railway systems and reduction of its economic impact with Energy Storage Systems, Int. J. Electr. Power Energy Syst. 93 (2017) 459–467. <https://doi.org/10.1016/j.ijepes.2017.06.022>.
- [28] M.B. Richardson, Flywheel energy storage system for traction applications, in: Int. Conf. Power Electron. Mach. Drives, 2002: pp. 275–279. <Go to ISI>://000177846400049.
- [29] T. Konishi, H. Morimoto, T. Aihara, M. Tsutakawa, Fixed Energy Storage Technology Applied for DC Electrified Railway, IEEJ Trans. Electr. Electron. Eng. 5 (2010) 270–277. <https://doi.org/10.1002/tee.20529>.

- [30] A. Rufer, D. Hotellier, P. Barrade, A supercapacitor-based energy-storage substation for voltage-compensation in weak transportation networks, in: 2003 IEEE Bologna Power Tech Conf. Proc., 2003: p. 8 pp. Vol.3-. <https://doi.org/10.1109/PTC.2003.1304470>.
- [31] Siemens, SITRAS® SES Acumulador de energía para el transporte de cercanías, (n.d.).
- [32] S. De-Leon, D. Turner, Understanding Rail Wayside Energy Storage Requirements And Relative Costs For High-Power, High-Cyclable Technologies, Railway Gazette International, 2017. <https://www.railwaygazette.com/analysis/understanding-rail-wayside-energy-storage-requirements-and-relative-costs-for-high-power-high-cyclable-technologies/44754.article> (accessed March 29, 2023).
- [33] M. Brenna, M. Longo, W. Yaïci, M. Brenna, M. Longo, W. Yaïci, Modelling and Simulation of Electric Vehicle Fast Charging Stations Driven by High Speed Railway Systems, Energies 10 (2017) 1268. <https://doi.org/10.3390/en10091268>.
- [34] A. Fernandez-Rodriguez, A. Fernandez-Cardador, A.D. Santiago-Laporte, C. Rodriguez-Sanchez, A.P. Cucala, A.J. Lopez-Lopez, R.R. Pecharroman, Charging Electric Vehicles Using Regenerated Energy from Urban Railways, in: 2017 IEEE Veh. Power Propuls. Conf. VPPC, 2017: pp. 1–6. <https://doi.org/10.1109/VPPC.2017.8330998>.
- [35] A. Fernández-Rodríguez, A. Fernández-Cardador, A.P. Cucala, M.C. Falvo, Energy Efficiency and Integration of Urban Electrical Transport Systems: EVs and Metro-Trains of Two Real European Lines, Energies 12 (2019) 366. <https://doi.org/10.3390/en12030366>.
- [36] S. Menicanti, M. di Benedetto, D. Marinelli, F. Crescimbinì, Recovery of Trains' Braking Energy in a Railway Micro-Grid Devoted to Train plus Electric Vehicle Integrated Mobility, Energies 15 (2022) 1261. <https://doi.org/10.3390/en15041261>.
- [37] P. Radu, M. Lewandowski, A. Szelag, On-Board and Wayside Energy Storage Devices Applications in Urban Transport Systems—Case Study Analysis for Power Applications, Energies 13 (2020) 2013. <https://doi.org/10.3390/en13082013>.
- [38] SAFT, Capturing energy from train braking in Philadelphia – a world first, France, 2013. <https://www.saft.com/case-studies/capturing-energy-train-braking-philadelphia-%E2%80%93-world-first-0> (accessed May 16, 2023).

- [39] A. Gillespie, E.S. Johanson, D.T. Montvydas, Energy Storage in Pennsylvania: SEPTA's Novel and Innovative Integration of Emerging Smart Grid Technologies, *IEEE Veh. Technol. Mag.* 9 (2014) 76–86. <https://doi.org/10.1109/MVT.2014.2313030>.
- [40] A.J. Gillespie, E.S. Johanson, SEPTA's (Southeastern Pennsylvania Transit Authority) Wayside Energy Storage Project, in: 2014. https://library.e.abb.com/public/b5454890543c446882b436758426ce5f/Septa_WhitePaper_V1.pdf (accessed May 16, 2023).
- [41] Business Wire, Siemens Installing First Regenerative Energy Storage Unit in the U.S. on New TriMet Light Rail Line, *Bus. Wire* (2013). <https://www.businesswire.com/news/home/20130603005502/en/Siemens-Installing-First-Regenerative-Energy-Storage-Unit-in-the-U.S.-on-New-TriMet-Light-Rail-Line> (accessed May 17, 2023).
- [42] L. García-Tabarés, J. Iglesias, M. Lafoz, J. Martinez, C. Vázquez, C. Tobajas, A. Gomez-Alors, A. Echeandia, J. Lucas, C. Zuazo, J. Carrasco, S. Vazquez, Development and Testing of a 200 MJ / 350 kW Kinetic Energy Storage System for Railways Applications, in: 2011. <https://www.semanticscholar.org/paper/Development-and-Testing-of-a-200-MJ-350-kW-Kinetic-Garc%C3%ADa-Tabar%C3%A9s-Iglesias/79b2aadcf0497722c0ddc1c736b9a08e914775ae> (accessed April 18, 2023).
- [43] O. Solis, F. Castro, L. Bukhin, K. Pham, D. Turner, G. Thompson, Saving Money Every Day: LA Metro Subway Wayside Energy Storage Substation, in: *American Society of Mechanical Engineers Digital Collection*, 2015. <https://doi.org/10.1115/JRC2015-5691>.
- [44] Y. Iino, H. Hayashiya, M. Hino, S. Abe, K. Nakao, K. Kudo, Evaluation of installation effect of the energy storage system in D.C. traction power supply system, in: 2016 IEEE Int. Power Electron. Motion Control Conf. PEMC, 2016: pp. 280–285. <https://doi.org/10.1109/EPEPEMC.2016.7752011>.
- [45] H. Hayashiya, Recent Trend of Regenerative Energy Utilization in Traction Power Supply System in Japan, *Urban Rail Transit* 3 (2017) 183–191. <https://doi.org/10.1007/s40864-017-0070-4>.
- [46] S. Takahashi, T. Uemura, S. Kon, H. Nebashi, Effect evaluation of electric double-layer capacitor (EDLC) for regenerative braking energy utilization in sinjuku line, Seibu railway,

in: IECON 2017 - 43rd Annu. Conf. IEEE Ind. Electron. Soc., 2017: pp. 3881–3883.
<https://doi.org/10.1109/IECON.2017.8216663>.

- [47] P. Jandura, A. Richter, Ž. Ferková, Flywheel energy storage system for city railway, in: 2016: pp. 1155–1159. <https://doi.org/10.1109/SPEEDAM.2016.7525923>.
- [48] M. Khodaparastan, O. Dutta, M. Saleh, A.A. Mohamed, Modeling and Simulation of DC Electric Rail Transit Systems With Wayside Energy Storage, *IEEE Trans. Veh. Technol.* 68 (2019) 2218–2228. <https://doi.org/10.1109/TVT.2019.2895026>.
- [49] M. Khodaparastan, A. Mohamed, A study on super capacitor wayside connection for energy recuperation in electric rail systems, in: 2017 IEEE Power Energy Soc. Gen. Meet., 2017: pp. 1–5. <https://doi.org/10.1109/PESGM.2017.8273915>.
- [50] R. Lamedica, A. Ruvio, L. Palagi, N. Mortelliti, Optimal Siting and Sizing of Wayside Energy Storage Systems in a D.C. Railway Line, *Energies* 13 (2020) 6271. <https://doi.org/10.3390/en13236271>.
- [51] D. Iannuzzi, D. Lauria, P. Tricoli, Optimal design of stationary supercapacitors storage devices for light electrical transportation systems, *Optim. Eng.* 13 (2012) 1–16. <https://doi.org/10.1007/s11081-011-9160-4>.
- [52] S. de la Torre, A. Sanchez-Racero, J. Aguado, M. Reyes, O. Martiane, Optimal Sizing of Energy Storage for Regenerative Braking in Electric Railway Systems, *IEEE Trans. Power Syst.* 30 (2014) 1–9. <https://doi.org/10.1109/TPWRS.2014.2340911>.
- [53] F. Ciccarelli, D. Iannuzzi, P. Tricoli, Control of metro-trains equipped with onboard supercapacitors for energy saving and reduction of power peak demand, *Transp. Res. Part C Emerg. Technol.* 24 (2012) 36–49. <https://doi.org/10.1016/j.trc.2012.02.001>.
- [54] F. Ciccarelli, D. Iannuzzi, D. Lauria, P. Natale, Optimal Control of Stationary Lithium-Ion Capacitor-Based Storage Device for Light Electrical Transportation Network, *IEEE Trans. Transp. Electrification* 3 (2017) 618–631. <https://doi.org/10.1109/TTE.2017.2739399>.
- [55] T. Suzuki, H. Hayashiya, T. Yamanoi, K. Kawahara, Introduction and Practical Use of Energy Storage System with Lithium-ion Battery for DC Traction Power Supply System, *IEEJ J. Ind. Appl.* 5 (2016) 20–25. <https://doi.org/10.1541/ieejia.5.20>.

- [56] W.A.G. de Jager, M. Huizer, E.K.H. van der Pols, Implementation of an Active Regeneration Unit in a traction substation, in: 2014 16th Eur. Conf. Power Electron. Appl., 2014: pp. 1–9. <https://doi.org/10.1109/EPE.2014.6911054>.
- [57] V. Calderaro, V. Galdi, G. Graber, A. Piccolo, Optimal siting and sizing of stationary supercapacitors in a metro network using PSO, in: 2015 IEEE Int. Conf. Ind. Technol. ICIT, 2015: pp. 2680–2685. <https://doi.org/10.1109/ICIT.2015.7125493>.
- [58] M. Ceraolo, G. Lutzemberger, Stationary and on-board storage systems to enhance energy and cost efficiency of tramways, *J. Power Sources* 264 (2014) 128–139. <https://doi.org/10.1016/j.jpowsour.2014.04.070>.
- [59] M. Saeed, F. Briz, J.M. Guerrero, I. Larrazabal, D. Ortega, V. Lopez, J.J. Valera, Onboard Energy Storage Systems for Railway: Present and Trends, *IEEE Open J. Ind. Appl.* 4 (2023) 238–259. <https://doi.org/10.1109/OJIA.2023.3293059>.
- [60] E. Fedele, D. Iannuzzi, A. Del Pizzo, Onboard energy storage in rail transport: Review of real applications and techno-economic assessments, *IET Electr. Syst. Transp.* 11 (2021) 279–309. <https://doi.org/10.1049/els2.12026>.
- [61] C. Lamontagne, Advanced Wayside Energy Storage Systems for Rail Transit, Navigant Consulting, Inc., Burlington, MA, 2013. <https://www.trb.org/Main/Blurbs/169959.aspx> (accessed March 30, 2023).
- [62] F. Meishner, D.U. Sauer, Wayside energy recovery systems in DC urban railway grids, *eTransportation* 1 (2019) 100001. <https://doi.org/10.1016/j.etrans.2019.04.001>.
- [63] T. Konishi, M. Tobita, Fixed energy storage technology applied for DC electrified railway (traction power substation), in: *Railw. Ship Propuls. 2012 Electr. Syst. Aircr.*, 2012: pp. 1–6. <https://doi.org/10.1109/ESARS.2012.6387438>.
- [64] L. Allen, Optimizing speed profiles for sustainable train operation with wayside energy storage systems, New Jersey Institute of Technology, 2022. <https://digitalcommons.njit.edu/dissertations/1593>.
- [65] M. Dominguez, A. Fernández-Cardador, A.P. Cucala, R.R. Pecharroman, Energy Savings in Metropolitan Railway Substations Through Regenerative Energy Recovery and Optimal

- Design of ATO Speed Profiles, *IEEE Trans. Autom. Sci. Eng.* 9 (2012) 496–504. <https://doi.org/10.1109/TASE.2012.2201148>.
- [66] M. Lyu, D. Kong, M. Miyatake, Optimal Energy Dispatch of Energy Storage System as a Shared Infrastructure between DC Railway Network and DC Micro Grid, in: 2022 25th Int. Conf. Electr. Mach. Syst. ICEMS, 2022: pp. 1–6. <https://doi.org/10.1109/ICEMS56177.2022.9983178>.
- [67] S. Akbari, S. Fazel, H. Hashemi-Dezaki, Energy Management of Networked Smart Railway Stations Considering Regenerative Braking, Energy Storage System, and Photovoltaic Units, *Energy Eng.* 120 (2022) 69–86. <https://doi.org/10.32604/ee.2022.024121>.
- [68] A. González-Gil, R. Palacin, P. Batty, Sustainable urban rail systems: Strategies and technologies for optimal management of regenerative braking energy, *Energy Convers. Manag.* 75 (2013) 374–388. <https://doi.org/10.1016/j.enconman.2013.06.039>.
- [69] M. Khodaparastan, A. Mohamed, Flywheel vs. Supercapacitor as Wayside Energy Storage for Electric Rail Transit Systems, *Inventions* 4 (2019) 62. <https://doi.org/10.3390/inventions4040062>.
- [70] X. Liu, K. Li, Energy storage devices in electrified railway systems: A review, *Transp. Saf. Environ.* 2 (2020) 183–201. <https://doi.org/10.1093/tse/tdaa016>.
- [71] M. Popescu, A. Bitoleanu, A Review of the Energy Efficiency Improvement in DC Railway Systems, *Energies* 12 (2019) 1092. <https://doi.org/10.3390/en12061092>.
- [72] D. Murray-Smith, A Review of Developments in Electrical Battery, Fuel Cell and Energy Recovery Systems for Railway Applications A Report for the Scottish Association for Public Transport, 2019. <https://doi.org/10.13140/RG.2.2.16555.67362>.
- [73] N. Ghaviha, J. Campillo, M. Bohlin, E. Dahlquist, Review of Application of Energy Storage Devices in Railway Transportation, *Energy Procedia* 105 (2017) 4561–4568. <https://doi.org/10.1016/j.egypro.2017.03.980>.
- [74] S. Koohi-Fayegh, M.A. Rosen, A review of energy storage types, applications and recent developments, *J. Energy Storage* 27 (2020) 101047. <https://doi.org/10.1016/j.est.2019.101047>.

- [75] F. Pierie, C. van Someren, Energy storage label: a method for comparing storage systems over all ranges, Hanzehogeschool Groningen, 2015.
- [76] A. Chatzivasileiadi, E. Ampatzi, I. Knight, Characteristics of electrical energy storage technologies and their applications in buildings, *Renew. Sustain. Energy Rev.* 25 (2013) 814–830. <https://doi.org/10.1016/j.rser.2013.05.023>.
- [77] H. Ibrahim, A. Ilinca, J. Perron, Energy storage systems—Characteristics and comparisons, *Renew. Sustain. Energy Rev.* 12 (2008) 1221–1250. <https://doi.org/10.1016/j.rser.2007.01.023>.
- [78] R. Amirante, E. Cassone, E. Distaso, P. Tamburrano, Overview on recent developments in energy storage: Mechanical, electrochemical and hydrogen technologies, *Energy Convers. Manag.* 132 (2017) 372–387. <https://doi.org/10.1016/j.enconman.2016.11.046>.
- [79] S. Vazquez, S.M. Lukic, E. Galvan, L.G. Franquelo, J.M. Carrasco, Energy Storage Systems for Transport and Grid Applications, *IEEE Trans. Ind. Electron.* 57 (2010) 3881–3895. <https://doi.org/10.1109/TIE.2010.2076414>.
- [80] Asian Development Bank, Handbook on Battery Energy Storage System, 0 ed., Asian Development Bank, Manila, Philippines, 2018. <https://doi.org/10.22617/TCS189791-2>.
- [81] B. Becker, M.E. Gil Bardají, J.-M. Durand, P. Clerens, M. Noe, EASE-EERA Energy Storage Technology Development Roadmap 2017, European Association for Storage of Energy, Brussels, 2017. <https://ease-storage.eu/publication/ease-eera-energy-storage-technology-development-roadmap-2017/> (accessed April 24, 2023).
- [82] Directorate General for Energy, Commission Staff Working Document on Energy Storage – the role of electricity, European Commission, 2017. https://energy.ec.europa.eu/publications/commission-staff-working-document-energy-storage-role-electricity_en (accessed April 26, 2023).
- [83] ECOFYS, Energy Storage Opportunities and Challenges, A West Coast Perspective White Paper - OurEnergyPolicy, 2014. <https://www.ourenergypolicy.org/resources/energy-storage-opportunities-and-challenges-a-west-coast-perspective-white-paper/> (accessed April 24, 2023).

- [84] IEC, Electrical Energy Storage, International Electrotechnical Commission, Switzerland, 2011. <https://www.iec.ch/basecamp/electrical-energy-storage> (accessed April 26, 2023).
- [85] A.A. Kebede, T. Kalogiannis, J. Van Mierlo, M. Berecibar, A comprehensive review of stationary energy storage devices for large scale renewable energy sources grid integration, *Renew. Sustain. Energy Rev.* 159 (2022) 112213. <https://doi.org/10.1016/j.rser.2022.112213>.
- [86] O. Krishan, S. Suhag, An updated review of energy storage systems: Classification and applications in distributed generation power systems incorporating renewable energy resources, *Int. J. Energy Res.* 43 (2019) 6171–6210. <https://doi.org/10.1002/er.4285>.
- [87] S. Martinez Romero, W. Hughes, Bringing Variable Renewable Energy Up to Scale: Options for Grid Integration Using Natural Gas and Energy Storage, The World Bank Group, 2015. <https://econpapers.repec.org/paper/wbkwbooper/21629.htm> (accessed May 8, 2023).
- [88] NWEUROPE, State of the Art Report on Storage Technologies, Opportunities and Trends, European Union, Interreg NWE, 2021. <https://www.nweurope.eu/projects/project-search/steps-storage-of-energy-power-systems-in-nwe/news/state-of-the-art-report-on-storage-technologies-opportunities-and-trends/> (accessed April 24, 2023).
- [89] O. Palizban, K. Kauhaniemi, Energy storage systems in modern grids—Matrix of technologies and applications, *J. Energy Storage* 6 (2016) 248–259. <https://doi.org/10.1016/j.est.2016.02.001>.
- [90] M.M. Rahman, A.O. Oni, E. Gemechu, A. Kumar, Assessment of energy storage technologies: A review, *Energy Convers. Manag.* 223 (2020) 113295. <https://doi.org/10.1016/j.enconman.2020.113295>.
- [91] H. Zhao, Q. Wu, S. Hu, H. Xu, C.N. Rasmussen, Review of energy storage system for wind power integration support, *Appl. Energy* 137 (2015) 545–553. <https://doi.org/10.1016/j.apenergy.2014.04.103>.
- [92] J. Mitali, S. Dhinakaran, A.A. Mohamad, Energy storage systems: a review, *Energy Storage Sav.* 1 (2022) 166–216. <https://doi.org/10.1016/j.enss.2022.07.002>.

- [93] Energy Storage Association Homepage | ESA, Energy Storage Assoc. (n.d.). <https://energystorage.org/> (accessed April 11, 2023).
- [94] European Commission, Batteries for Energy Storage in the European Union, (2022). https://setis.ec.europa.eu/batteries-energy-storage-european-union_en (accessed April 28, 2023).
- [95] E. Hossain, H.M.R. Faruque, M.S.H. Sunny, N. Mohammad, N. Nawar, A Comprehensive Review on Energy Storage Systems: Types, Comparison, Current Scenario, Applications, Barriers, and Potential Solutions, Policies, and Future Prospects, *Energies* 13 (2020) 3651. <https://doi.org/10.3390/en13143651>.
- [96] F. Díaz-González, A. Sumper, O. Gomis-Bellmunt, R. Villafáfila-Robles, A review of energy storage technologies for wind power applications, *Renew. Sustain. Energy Rev.* 16 (2012) 2154–2171. <https://doi.org/10.1016/j.rser.2012.01.029>.
- [97] W. Tahil, The trouble with lithium, *Implic. Future PHEV Prod. Lithium Demand Martainville Meridian Int. Res.* (2007).
- [98] M. Novales, Light Rail Systems Free of Overhead Wires, *Transp. Res. Rec.* 2219 (2011) 30–37. <https://doi.org/10.3141/2219-04>.
- [99] S. Hajiabady, Energy storage system for railway applications & analysis and modelling of electrochemical batteries for conductor rail gap DC railway - CORE, University of Birmingham, 2013. <https://core.ac.uk/display/20440517> (accessed April 25, 2023).
- [100] R. Carnegie, D. Gotham, D. Nderitu, P.V. Preckel, Utility Scale Energy Storage Systems. Benefits, Applications, and Technologies, State Utility Forecasting Group, 2013.
- [101] Á. Cunha, J. Martins, N. Rodrigues, F. Brito, Vanadium redox flow batteries: A technology review, *Int. J. Energy Res.* 39 (2014). <https://doi.org/10.1002/er.3260>.
- [102] K. Cavanagh, J. Ward, S. Behrens, A. Bhatt, E. Ratnam, E. Oliver, J. Hayward, *Electrical Energy Storage: Technology Overview and Applications*, 2015.
- [103] IEA, *Prospects for Large-Scale Energy Storage in Decarbonised Power Grids*, International Energy Agency, Paris, 2009. <https://www.iea.org/reports/prospects-for-large-scale-energy-storage-in-decarbonised-power-grids>.

- [104] H. Chen, T.N. Cong, W. Yang, C. Tan, Y. Li, Y. Ding, Progress in electrical energy storage system: A critical review, *Prog. Nat. Sci.* 19 (2009) 291–312. <https://doi.org/10.1016/j.pnsc.2008.07.014>.
- [105] S. Sabihuddin, A.E. Kiprakis, M. Mueller, A Numerical and Graphical Review of Energy Storage Technologies, *Energies* 8 (2015) 172–216. <https://doi.org/10.3390/en8010172>.
- [106] C.-J. Winter, Hydrogen energy — Abundant, efficient, clean: A debate over the energy-system-of-change, *Int. J. Hydrog. Energy* 34 (2009) S1–S52. <https://doi.org/10.1016/j.ijhydene.2009.05.063>.
- [107] P. Nikolaidis, A. Poullikkas, Cost metrics of electrical energy storage technologies in potential power system operations, *Sustain. Energy Technol. Assess.* 25 (2018) 43–59. <https://doi.org/10.1016/j.seta.2017.12.001>.
- [108] UIC, Keeping Climate Change Solutions on Track. The Role of Rail, 2010.
- [109] M. Haji Akhondzadeh, S. Panchal, E. Samadani, K. Raahemifar, M. Fowler, R. Fraser, Investigation and simulation of electric train utilizing hydrogen fuel cell and lithium-ion battery, *Sustain. Energy Technol. Assess.* 46 (2021) 101234. <https://doi.org/10.1016/j.seta.2021.101234>.
- [110] X. Luo, J. Wang, M. Dooner, J. Clarke, Overview of current development in electrical energy storage technologies and the application potential in power system operation, *Appl. Energy* 137 (2015) 511–536. <https://doi.org/10.1016/j.apenergy.2014.09.081>.
- [111] A.A. Akhil, G. Huff, A.B. Currier, B.C. Kaun, D.M. Rastler, S.B. Chen, A.L. Cotter, D.T. Bradshaw, W.D. Gauntlett, DOE/EPRI Electricity Storage Handbook in Collaboration with NRECA., Sandia National Lab. (SNL-NM), Albuquerque, NM (United States), 2015. <https://doi.org/10.2172/1170618>.
- [112] A. Evans, V. Strezov, T.J. Evans, Assessment of utility energy storage options for increased renewable energy penetration, *Renew. Sustain. Energy Rev.* 16 (2012) 4141–4147. <https://doi.org/10.1016/j.rser.2012.03.048>.
- [113] S.E. Gay, M. Ehsani, On-board electrically peaking drive train for electric railway vehicles, in: *Proc. IEEE 56th Veh. Technol. Conf.*, 2002: pp. 998–1001 vol.2. <https://doi.org/10.1109/VETECF.2002.1040751>.

- [114] R. Barrero, X. Tackoen, J. van Mierlo, Stationary or onboard energy storage systems for energy consumption reduction in a metro network, *Proc. Inst. Mech. Eng. Part F J. Rail Rapid Transit* 224 (2010) 207–225. <https://doi.org/10.1243/09544097JRRT322>.
- [115] M. Miyatake, H. Haga, S. Suzuki, Optimal speed control of a train with On-board energy storage for minimum energy consumption in catenary free operation, in: 2009 13th Eur. Conf. Power Electron. Appl., 2009: pp. 1–9.
- [116] B. Destraz, P. Barrade, A. Rufer, M. Klohr, Study and simulation of the energy balance of an urban transportation network, in: 2007 Eur. Conf. Power Electron. Appl., IEEE, Aalborg, Denmark, 2007: pp. 1–10. <Go to ISI>://000255993603105.
- [117] M. Miyatake, K. Matsuda, Energy Saving Speed and Charge/Discharge Control of a Railway Vehicle with On-board Energy Storage by Means of an Optimization Model, *IEEJ Trans. Electr. Electron. Eng.* 4 (2009) 771–778. <https://doi.org/10.1002/tee.20479>.
- [118] M. Miyatake, K. Matsuda, Optimal speed and charge/discharge control of a train with onboard energy storage devices for minimum energy operation, in: 2008 Int. Symp. Power Electron. Electr. Drives Autom. Motion SPEEDAM, IEEE, 2008. DOI: 10.1109/SPEEDHAM.2008.4581323. <http://search.ebscohost.com/login.aspx?direct=true&db=inh&AN=10141044> <=es&site=ehost-liveDOI: 10.1109/SPEEDHAM.2008.4581323.
- [119] M. Steiner, M. Klohr, S. Pagiela, Energy storage system with ultracaps on board of railway vehicles, in: 2007 Eur. Conf. Power Electron. Appl., 2007: pp. 1–10. <https://doi.org/10.1109/EPE.2007.4417400>.
- [120] E. Agenjos, A. Gabaldon, F.G. Franco, R. Molina, S. Valero, M. Ortiz, R.J. Gabaldon, Energy efficiency in railways: Energy storage and electric generation in diesel electric locomotives, in: CIREN 2009 - 20th Int. Conf. Exhib. Electr. Distrib. - Part 1, 2009: pp. 1–7. <https://doi.org/10.1049/cp.2009.0734>.
- [121] P. Arbolea, I. El-Sayed, B. Mohamed, C. Mayet, Modeling, Simulation and Analysis of On-Board Hybrid Energy Storage Systems for Railway Applications, *Energies* 12 (2019) 2199. <https://doi.org/10.3390/en12112199>.

- [122] J. Chen, H. Hu, Y. Ge, K. Wang, W. Huang, Z. He, An Energy Storage System for Recycling Regenerative Braking Energy in High-Speed Railway, *IEEE Trans. Power Deliv.* 36 (2021) 320–330. <https://doi.org/10.1109/TPWRD.2020.2980018>.
- [123] B. Maher, Ultracapacitors provide cost and energy savings for public transportation applications, *Battery Power Prod. Technol.* 10 (2006).
- [124] M. Brenna, V. Bucci, M.C. Falvo, F. Foadelli, A. Ruvio, G. Sulligoi, A. Vicenzutti, A Review on Energy Efficiency in Three Transportation Sectors: Railways, Electrical Vehicles and Marine, *Energies* 13 (2020) 2378. <https://doi.org/10.3390/en13092378>.
- [125] T. Ise, M. Kita, A. Taguchi, A hybrid energy storage with a SMES and secondary battery, *IEEE Trans. Appl. Supercond.* 15 (2005) 1915–1918. <https://doi.org/10.1109/TASC.2005.849333>.
- [126] S. Suzuki, J. Baba, K. Shutoh, E. Masada, Effective application of superconducting magnetic energy storage (SMES) to load leveling for high speed transportation system, *IEEE Trans. Appl. Supercond.* 14 (2004) 713–716. <https://doi.org/10.1109/TASC.2004.830082>.
- [127] I.P. Gyuk, S. Eckroad, EPRI-DOE Handbook of Energy Storage for Transmission & Distribution Applications, EPRI and the U.S. Department of Energy, Palo Alto, CA and Washington, DC, 2003.
- [128] M. Chymera, A. Renfrew, M. Barnes, Energy Storage Devices in Railway Systems, Austin Court, Birmingham, UK, 2006.
- [129] M. Meinert, New mobile energy storage system for rolling stock, in: 2009 13th Eur. Conf. Power Electron. Appl., 2009: pp. 1–10.
- [130] J.-P. Moskowitz, J.-L. Cohuau, STEEM: ALSTOM and RATP experience of supercapacitors in tramway operation, in: 2010 IEEE Veh. Power Propuls. Conf., 2010: pp. 1–5. <https://doi.org/10.1109/VPPC.2010.5729152>.
- [131] Toshiba, Rechargeable Li-ion battery SCiB, (2023). <https://www.global.toshiba/content/dam/toshiba/ww/products-solutions/battery/scib/pdf/ToshibaRechargeableBattery-en.pdf> (accessed June 23, 2023).

- [132] Toshiba, Railways & Boats | SCiB™ Rechargeable battery | Toshiba, (n.d.). <https://www.global.toshiba/ww/products-solutions/battery/scib/cases/railway-ship.html> (accessed June 23, 2023).
- [133] Siemens, A.G, Sitras HES Hybrid energy storage system for rail vehicles, (2014). <https://assets.new.siemens.com/siemens/assets/api/uuid:aa06262d-3ebf-4bcb-9566-bd6b0db960a5/productinformation-sitras-hes-e.pdf> (accessed June 14, 2023).
- [134] Centum Adetel Transportation Solution, OFF Wire & ZEMU Latest developments in Catenary Free Operation, (2019). https://www.heritagetrolley.org/images/Centum_Adetel_APTA_NJ_190407.pdf (accessed June 14, 2023).
- [135] B. Ferreras, El tranvía se suelta de la catenaria | País Vasco | elmundo.es, (2010). <https://www.elmundo.es/elmundo/2010/02/22/paisvasco/1266830656.html> (accessed June 5, 2023).
- [136] M. Khodaparastan, A.A. Mohamed, W. Brandauer, Recuperation of Regenerative Braking Energy in Electric Rail Transit Systems, IEEE Trans. Intell. Transp. Syst. 20 (2019) 2831–2847. <https://doi.org/10.1109/TITS.2018.2886809>.
- [137] M. Khodaparastan, A. Mohamed, Supercapacitors for electric rail transit systems, in: 2017 IEEE 6th Int. Conf. Renew. Energy Res. Appl. ICRERA, 2017: pp. 896–901. <https://doi.org/10.1109/ICRERA.2017.8191189>.
- [138] J. Swanson, J. Smatlak, State of the art in light rail alternative power supplies, in: 2015: p. 47.
- [139] Interempresas, Maxwell proporciona sus ultracondensadores a CAF para sus módulos ferroviarios sin catenaria, Interempresas (2016). <https://www.interempresas.net/Electronica/Articulos/150240-Maxwell-proporciona-ultracondensadores-CAF-modulos-ferroviarios-sin-catenaria.html> (accessed June 5, 2023).
- [140] J. Araúz Sarmiento, F. Henriquez, J. de D. Sanz Bobi, A. Berbey-Alvarez, 2021 Desarrollo e innovacion en ingenieria Vol. I.Tecnologías y enfoques para el aprovechamiento de la energía regenerativa en el transporte ferroviario: Una revisión sistemática, in: 2021: pp. 475–500.

- [141] M. Ogasa, Application of Energy Storage Technologies for Electric Railway Vehicles—Examples with Hybrid Electric Railway Vehicles, *IEEJ Trans. Electr. Electron. Eng.* 5 (2010) 304–311. <https://doi.org/10.1002/tee.20534>.
- [142] A. Rufer, Energy storage for railway systems, energy recovery and vehicle autonomy in Europe, in: 2010 Int. Power Electron. Conf. IPEC - Sapporo, IEEE, Sapporo, Japan, 2010: pp. 3124–3127. DOI: 10.1109/IPEC.2010.5542334. <http://search.ebscohost.com/login.aspx?direct=true&db=inh&AN=11496639> <Go to ISI>://000255993600109. DOI: 10.1109/IPEC.2010.5542334.
- [143] D.M. Steiner, M. Klohr, S. Pagiela, Energy storage system with Ultracaps on board of railway vehicles, in: 2007 Eur. Conf. Power Electron. Appl., IEEE, Aalborg, Denmark, 2007. <Go to ISI>://000255993600109.
- [144] M. Steiner, J. Scholten, Energy storage on board of DC fed railway vehicles PESC 2004 Conference in Aachen, Germany, in: Power Electron. Spec. Conf. 2004 PESC 04 2004 IEEE 35th Annu., 2004: pp. 666–671. <Go to ISI>://000224587600107.
- [145] Bombardier, Green Light for New Bombardier Trams of Rhein-Neckar-Verkehr GmbH with Innovative Energy Storage, Bombardier (2009). <https://bombardier.com/en/media/news/green-light-new-bombardier-trams-rhein-neckar-verkehr-gmbh-innovative-energy-storage> (accessed June 6, 2023).
- [146] F. Lacôte, Alstom : future trends in railway transportation, *Jpn. Railw. Transp. Rev.* (2005). <https://www.semanticscholar.org/paper/Alstom-%3A-future-trends-in-railway-transportation-ote/ae6242502dd7087e3b20ffaad7c74eebd2f5cab8> (accessed May 17, 2023).
- [147] Siemens, A.G, Increasing Energy Efficiency Optimized Traction Power Supply in Mass Transit Systems, (2011). https://kipdf.com/rail-electrification_5ac3f2361723dd3a8f78ae1c.html.
- [148] M. Shimada, R. Oishi, D. Araki, Y. Nakamura, Energy Storage System for Effective Use of Regenerative Energy in Electrified Railways, (2010).
- [149] Railway Gazette International, LFX-300 Ameritram hybrid streetcar unveiled in Charlotte, *Railw. Gaz. Int.* (2011). <https://www.railwaygazette.com/lfx-300-ameritram-hybrid-streetcar-unveiled-in-charlotte/35646.article> (accessed May 31, 2023).

- [150] A. Croset, Energy storage for existing DC networks and catenary free solutions, in: 2015. <https://trid.trb.org/view/1412038> (accessed May 12, 2023).
- [151] H. Alnuman, D.T. Gladwin, Energy Storage Application into a Double DC Electric Railway, *Energy Procedia* 151 (2018) 12–16. <https://doi.org/10.1016/j.egypro.2018.09.020>.
- [152] D. Roch-Dupré, T. Gonsalves, A.P. Cucala, R.R. Pecharromán, Á.J. López-López, A. Fernández-Cardador, Multi-stage optimization of the installation of Energy Storage Systems in railway electrical infrastructures with nature-inspired optimization algorithms, *Eng. Appl. Artif. Intell.* 104 (2021) 104370. <https://doi.org/10.1016/j.engappai.2021.104370>.
- [153] D. Roch-Dupré, C. Camacho-Gómez, A.P. Cucala, S. Jiménez-Fernández, Á. López-López, A. Portilla-Figueras, R.R. Pecharromán, A. Fernández-Cardador, S. Salcedo-Sanz, Optimal Location and Sizing of Energy Storage Systems in DC-Electrified Railway Lines Using a Coral Reefs Optimization Algorithm with Substrate Layers, *Energies* 14 (2021) 4753. <https://doi.org/10.3390/en14164753>.
- [154] D. Roch-Dupré, T. Gonsalves, A.P. Cucala, R.R. Pecharromán, Á.J. López-López, A. Fernández-Cardador, Determining the optimum installation of energy storage systems in railway electrical infrastructures by means of swarm and evolutionary optimization algorithms, *Int. J. Electr. Power Energy Syst.* 124 (2021) 106295. <https://doi.org/10.1016/j.ijepes.2020.106295>.
- [155] European Commission, Construction of a demonstration flywheel energy-storage systems for the reduction of the energy-consumption in public light-rail systems by up to 10%, 2021. <https://webgate.ec.europa.eu/life/publicWebsite/project/details/1202#> (accessed May 13, 2023).
- [156] UIC - International Union of Railways, Technologies - Stationary energy storage, (2002). https://www.railway-energy.org/tfee/index.php?ID=220&TECHNOLOGYID=50&SEL=210&SEKTION=Sec2_detail (accessed May 29, 2023).
- [157] F.-O. Devaux, X. Tackoen, WP2B Energy Recovery: Overview of braking energy recovery technologies in the public transport field, 2011.

- <https://www.forschungsinformationssystem.de/servlet/is/469756/> (accessed May 12, 2023).
- [158] P. Radcliffe, J.S. Wallace, L.H. Shu, Stationary applications of energy storage technologies for transit systems, in: 2010 IEEE Electr. Power Energy Conf., 2010: pp. 1–7. <https://doi.org/10.1109/EPEC.2010.5697222>.
- [159] Siemens, Sitras SES Das Energiespeichersystem für den Nahverkehr, (n.d.). <https://docplayer.org/106465888-Sitras-ses-das-energiespeichersystem-fuer-den-nahverkehr.html> (accessed May 11, 2023).
- [160] Siemens, A.G, Sitras SES Energy Storage System for Mass Transit Systems, (n.d.). <https://docplayer.net/40444048-Sitras-ses-energy-storage-system-for-mass-transit-systems.html> (accessed May 25, 2023).
- [161] Railway Gazette International, Supercapacitor energy storage for South Island Line, Railw. Gaz. Int. (2012). <https://www.railwaygazette.com/supercapacitor-energy-storage-for-south-island-line/37142.article> (accessed May 12, 2023).
- [162] Woojin Industrial Systems, Energy storage system for railways, (n.d.). https://www.wjis.co.kr/en/business/energy_storage_railway.php (accessed May 12, 2023).
- [163] K. Kwon, E.-K. Lee, J. Choi, S.-G. Baek, Efficiency improvement of ESS for DC transit system, in: Proc. 7th Int. Power Electron. Motion Control Conf., 2012: pp. 2641–2646. <https://doi.org/10.1109/IPEMC.2012.6259278>.
- [164] Braking energy recovery moBiel (Bielefeld), 2014. https://www.stib-mivb.be/irj/go/km/docs/resource/tickettokyoto/sites/default/files/downloads/T2K_WP_2_Inv6_moBiel_braking_energy.pdf (accessed May 13, 2023).
- [165] Flösch, Projekt Stationärer Energiespeicher Landwasser Abschlussbericht, 2014. https://www.badenova.de/mediapool/media/dokumente/unternehmensbereiche_1/stab_1/innovationsfonds/abschlussberichte/2012_13/2012-06_AB_Energiespeicher_Landwasser.pdf (accessed May 13, 2023).

- [166] M. Bischof, Schwungrad als Energiespeicher in Bahnnetzen. Erfahrungen aus einem Versuchsprojekt in der Stadt Zürich, Bull. VSEAES Electrosuisse Verband Schweiz. Elektrizitätsunternehmen 101 (2010) 33–37.
- [167] A. Okui, S. Hase, H. Shigeeda, T. Konishi, T. Yoshi, Application of energy storage system for railway transportation in Japan, in: 2010 Int. Power Electron. Conf. - ECCE ASIA -, 2010: pp. 3117–3123. <https://doi.org/10.1109/IPEC.2010.5542321>.
- [168] ABB, ENVILINE EMS Energy Management Solution Recovery and receptivity of braking energy for DC rail transportation, (2017). <https://library.e.abb.com/public/60fe1e467cfc47f6a517de9868a2805b/ENVILINE%20EMS%20EN%20v2.pdf?x-sign=oX/K3aiLIcG5L7VfWVvyh7UN1bitUftUPavILEkB+Jg3zxL60HsrjjFhbCiqPnC> (accessed May 12, 2023).
- [169] ABB, Enviline™ ESS Energy Storage System brochure, (2020). <https://search.abb.com/library/Download.aspx?DocumentID=9AKK107680A8596&LanguageCode=en&DocumentPartId=&Action=Launch> (accessed May 12, 2023).
- [170] H. Gibson, SEPTA, Constellation, and Viridity Energy to deploy 8.75MW energy storage system to capture and reuse subway train braking energy, Green Car Congr. (2016). <https://www.greencarcongress.com/2016/01/20160122-septa.html> (accessed May 18, 2023).
- [171] SAFT, Intensium® Max 20 High Energy, (2019). https://www.norwatt.es/files/products/pdf/Intensium%E2%94%AC-Max-20-High-Energy_unlocked.pdf (accessed May 18, 2023).
- [172] Sojitz Corporation, Meidensha Corporation, Sojitz and Meidensha received Two Orders for Power Supply Equipment for the New Lines of MTR Corporation, (2012). <https://www.sojitz.com/en/news/2012/05/20120525.php> (accessed May 12, 2023).
- [173] M. Amiryar, K. Pullen, A Review of Flywheel Energy Storage System Technologies and Their Applications, Appl. Sci. 7 (2017) 286. <https://doi.org/10.3390/app7030286>.
- [174] Calnetix, VYCON® REGEN® The Proven Flywheel Energy Storage System for Rail, (2017). https://www.calnetix.com/sites/default/files/VYCON%20REGEN%20KINETIC%20BROCHURE_4_page_web_spread.pdf (accessed May 13, 2023).

- [175] V. Krishnan, REGEN for Rail. Flywheel Energy Storage, (2017).
https://www.calnetix.com/sites/default/files/Asia-Pacific%20Rail_20170320_FINAL.pdf
(accessed May 13, 2023).
- [176] Vycon, Los Angeles Metro Way Side Energy Storage System (WESS), VYCON (2017).
<https://vyconenergy.com/2017/06/07/los-angeles-metro-way-side-energy-storage-system-wess/> (accessed May 29, 2023).
- [177] Rosseta Technik GmbH, Energiespeicher für das Straßenbahnnetz, n.d.
<http://www.rosseta.de/texte/bahnsr.pdf> (accessed May 13, 2023).
- [178] Railway Gazette International, Flywheel firm launches, Railw. Gaz. Int. (2011).
<https://www.railwaygazette.com/flywheel-firm-launches/35630.article> (accessed May 16, 2023).
- [179] C. Tarrant, Kinetic energy storage wins acceptance, Railw. Gaz. Int. (2004).
<https://www.railwaygazette.com/kinetic-energy-storage-wins-acceptance/27250.article> (accessed May 16, 2023).
- [180] C.D. Tarrant, Kinetic Energy Storage: Solving Problems For Power Engineers Around The World, (2003). https://www.sandia.gov/ess-ssl/EESAT/2003_papers/Tarrant.pdf
(accessed May 29, 2023).
- [181] N. Wheeler, Voltage regulation application of a kinetic energy storage system, in: Second Int. Conf. Power Electron. Mach. Drives PEMD 2004, 2004: pp. 605-608 Vol.2.
<https://doi.org/10.1049/cp:20040357>.
- [182] A. Maoka, H. Ikarashi, F. Kurino, Demonstration testing and evaluation of a train running under its own power using a stationary energy storage system, Hitachi Rev. 63 (2014) 70–75.
- [183] Hitachi, News Releases : May 21, 2015 : Hitachi Global, (2015).
<https://www.hitachi.com/New/cnews/month/2015/05/150521.html> (accessed May 16, 2023).
- [184] K. Ogura, K. Nishimura, T. Matsumura, C. Tonda, E. Yoshiyama, M. Andriani, W. Francis, R.A. Schmitt, A. Visgotis, N. Gianfrancesco, Test Results of a High Capacity Wayside Energy Storage System Using Ni-MH Batteries for DC Electric Railway at New York City

Transit, in: 2011 IEEE Green Technol. Conf. IEEE-Green, 2011: pp. 1–6.
<https://doi.org/10.1109/GREEN.2011.5754859>.

- [185] Kawasaki, Battery Power System for Railways, 2015.
https://global.kawasaki.com/en/energy/solutions/battery_energy/download/pdf/catalog_bps.pdf (accessed May 16, 2023).
- [186] CIEMAT, USEP Unit of Electric Power Systems, Projects. SA2VE (2005-2010), Projects (n.d.). <http://rdgroups.ciemat.es/web/usep/projects> (accessed May 29, 2023).
- [187] H. Takahashi, T. Kato, T. Ito, F. Gunji, Energy Storage for Traction Power Supply Systems, 2008. http://www.sze.hu/~szenasy/VILLVONT/r2008_01_004.pdf (accessed May 29, 2023).
- [188] A. Du Pasquier, I. Plitz, S. Menocal, G. Amatucci, A comparative study of Li-ion battery, supercapacitor and nonaqueous asymmetric hybrid devices for automotive applications, *J. Power Sources* 115 (2003) 171–178. [https://doi.org/10.1016/S0378-7753\(02\)00718-8](https://doi.org/10.1016/S0378-7753(02)00718-8).
- [189] M. Aneke, M. Wang, Energy storage technologies and real life applications – A state of the art review, *Appl. Energy* 179 (2016) 350–377. <https://doi.org/10.1016/j.apenergy.2016.06.097>.
- [190] T.M.I. Mahlia, T.J. Saktisahdan, A. Jannifar, M.H. Hasan, H.S.C. Matseelar, A review of available methods and development on energy storage; technology update, *Renew. Sustain. Energy Rev.* 33 (2014) 532–545. <https://doi.org/10.1016/j.rser.2014.01.068>.
- [191] K. Mongird, V.V. Viswanathan, P.J. Balducci, M.J.E. Alam, V. Fotedar, V.S. Koritarov, B. Hadjerioua, Energy Storage Technology and Cost Characterization Report, Pacific Northwest National Lab. (PNNL), Richland, WA (United States), 2019. <https://doi.org/10.2172/1573487>.
- [192] P. Taylor, R. Bolton, D. Stone, X.-P. Zhang, C. Martin, P. Upham, Pathways for energy storage in the UK, Rep. Cent. Low Carbon Futur. York (2012).
- [193] A.G. Olabi, C. Onumaegbu, T. Wilberforce, M. Ramadan, M.A. Abdelkareem, A.H. Al – Alami, Critical review of energy storage systems, *Energy* 214 (2021) 118987. <https://doi.org/10.1016/j.energy.2020.118987>.

- [194] G. Simbolotti, R. Kempener, Electricity Storage. Technology Brief, Energy Technology Systems Analysis Programme ETSAP, International Energy Agency IEA, Paris (France); International Renewable Energy Agency IRENA, Bonn (Germany), Netherlands, 2012. <https://www.osti.gov/etdeweb/biblio/22028672> (accessed May 11, 2023).
- [195] T.M. Gür, Review of electrical energy storage technologies, materials and systems: challenges and prospects for large-scale grid storage, *Energy Environ. Sci.* 11 (2018) 2696–2767. <https://doi.org/10.1039/C8EE01419A>.
- [196] F. Nadeem, S.M.S. Hussain, P.K. Tiwari, A.K. Goswami, T.S. Ustun, Comparative Review of Energy Storage Systems, Their Roles, and Impacts on Future Power Systems, *IEEE Access* 7 (2019) 4555–4585. <https://doi.org/10.1109/ACCESS.2018.2888497>.
- [197] B. Zakeri, S. Syri, Electrical energy storage systems: A comparative life cycle cost analysis, *Renew. Sustain. Energy Rev.* 42 (2015) 569–596. <https://doi.org/10.1016/j.rser.2014.10.011>.
- [198] S. Faias, J. Sousa, R. Castro, An overview on short and long-term response energy storage devices for power systems applications, *Renew. Energy Power Qual. J.* 1 (2008). <https://doi.org/10.24084/repqj06.327>.
- [199] P. De Boer, J. Raadschelders, Flow batteries, *Leonardo Energy* 19 (2007) 1–9.
- [200] M. Guerrero, E. Romero, F. Barrero, M. Milanés, E. Gonzalez-Romera, Supercapacitors: Alternative Energy Storage Systems, *Przeład Elektrotechniczny* 85 (2009).
- [201] P. Nikolaidis, A. Poullikkas, A comparative review of electrical energy storage systems for better sustainability, *J. Power Technol.* (2017). <https://www.semanticscholar.org/paper/A-comparative-review-of-electrical-energy-storage-Nikolaidis-Poullikkas/c394452ee8602ef60eed98a4611b646f3e59d1cf> (accessed May 9, 2023).
- [202] D.V. Ragone, Review of Battery Systems for Electrically Powered Vehicles, in: 1968: p. 680453. <https://doi.org/10.4271/680453>.
- [203] X. Tan, Q. Li, H. Wang, Advances and trends of energy storage technology in Microgrid, *Int. J. Electr. Power Energy Syst.* 44 (2013) 179–191. <https://doi.org/10.1016/j.ijepes.2012.07.015>.

- [204] M.H. Mostafa, S.H.E. Abdel Aleem, S.G. Ali, Z.M. Ali, A.Y. Abdelaziz, Techno-economic assessment of energy storage systems using annualized life cycle cost of storage (LCCOS) and levelized cost of energy (LCOE) metrics, *J. Energy Storage* 29 (2020) 101345. <https://doi.org/10.1016/j.est.2020.101345>.
- [205] I. Hadjipaschalis, A. Poullikkas, V. Efthimiou, Overview of current and future energy storage technologies for electric power applications, *Renew. Sustain. Energy Rev.* 13 (2009) 1513–1522. <https://doi.org/10.1016/j.rser.2008.09.028>.
- [206] I. Chotia, S. Chowdhury, Battery storage and hybrid battery supercapacitor storage systems: A comparative critical review, in: *2015 IEEE Innov. Smart Grid Technol. - Asia ISGT ASIA*, 2015: pp. 1–6. <https://doi.org/10.1109/ISGT-Asia.2015.7387080>.
- [207] S.M. Schoenung, *Characteristics of Energy Storage Technologies for Short- and Long-Duration Applications*, (2002).

