



Co-optimizing network investment, reconfiguration, and third-party flexibility for congestion management in active distribution networks

Orlando Valarezo ^{a,*} , Tomás Gómez ^a, José Pablo Chaves-Ávila ^a , Cristian Alcarruz ^b, Pierluigi Mancarella ^{b,c}

^a Institute for Research in Technology (IIT), ICAI School of Engineering, Comillas Pontifical University, Madrid 28015 Spain

^b Department of Electrical and Electronic Engineering, The University of Melbourne, Parkville, Victoria 3010, Australia

^c Department of Electrical and Electronic Engineering, The University of Manchester, Oxford Rd., Manchester M13 9PL, United Kingdom

ARTICLE INFO

Keywords:

Distribution network reconfiguration
Congestion management
Distribution network planning
Flexibility services
Third-party flexibility
Topology optimization

ABSTRACT

This paper introduces a unified optimization model to evaluate three coordinated strategies for congestion management in distribution networks: investment in new assets, distribution network reconfiguration, and the procurement of third-party flexibility. Unlike existing models that consider these strategies in isolation, the proposed approach jointly optimizes capital and operational expenditures, explicitly capturing their trade-offs. This integrated perspective aligns with evolving regulatory frameworks that advocate for the coordination of conventional planning with operational and market-based flexibility. The model is applied across a range of scenarios, including load growth, varying flexibility capacities and costs, and different weightings of representative days.

Results indicate that reconfiguration alone may suffice under moderate demand growth, while greater availability of third-party flexibility can defer or substitute costly grid reinforcements. Under higher congestion conditions, the coordinated deployment of all three strategies delivers the most cost-effective and operationally robust outcomes. The analysis further reveals that grid reconfiguration dynamically alters the eligibility of service providers to deliver flexibility, underscoring the importance of incorporating reconfiguration into the design of third-party flexibility mechanisms and distribution network planning. The paper concludes by identifying key implementation challenges and future research directions, including the selection and weighting of representative days, assessment of switching costs, reliability of reconfigured topologies, uncertainty modeling, and the implications of coordinating multiple flexibility mechanisms for congestion management.

1. Introduction

1.1. Background and motivation

The ongoing transformation of power networks, driven by decarbonization policies, increasing demand electrification, and distributed energy resources (DERs) integration, brings substantial benefits, including reduced carbon emissions, enhanced energy security, grid modernization, and new business opportunities. However, these developments also introduce new technical, economic, and regulatory complexities in the operation and planning of power grids. In particular, modern distribution networks face challenges such as power flow variability, complexity in cost allocation among network users, growing coordination requirements between distribution system operators

(DSOs) and transmission system operators (TSOs), and grid congestions.

When addressing grid congestions, which is the primary focus of this paper, DSOs can adopt multiple strategies. Traditionally, mitigating forecasted congestion involves reinforcing or expanding the grid to enhance its capacity and resilience. However, investment (INV) in grid infrastructure requires significant financial resources. Grids are typically regulated assets whose investments are paid for by all consumers through network tariffs. Therefore, higher investment costs will generally increase network tariffs. A promising alternative is the use of the distribution system's operational flexibility to defer or even avoid these investment needs [1].

Flexibility in power systems has been defined in various ways across the literature [2–4]. It is generally understood as the ability of market participants to regulate their consumption or injection patterns in response to signals issued by system operators [2,3]. Additionally, [4]

* Corresponding author.

E-mail address: ovalarezo@comillas.edu (O. Valarezo).

<https://doi.org/10.1016/j.ijepes.2025.111094>

Received 11 May 2025; Received in revised form 12 July 2025; Accepted 4 September 2025

Available online 11 September 2025

0142-0615/© 2025 The Author(s). Published by Elsevier Ltd. This is an open access article under the CC BY license (<http://creativecommons.org/licenses/by/4.0/>).

Nomenclature**Abbreviations**

AP	Active Power
CAPEX	Capital Expenditures
DG(s)	Distributed Generator(s)
DLMP(s)	Distribution Locational Marginal Price(s)
DNPM(s)	Distribution Network Planning Model(s)
DNR	Distribution Network Reconfiguration
DR	Demand Response
DSO(s)	Distribution System Operator(s)
EENS	Expected Energy Not-Supplied
EUR	Euro
FSP(s)	Flexibility Service Provider(s)
GC	Generation Curtailment
INV	Investment
LDC	Load Duration Curve
LFM(s)	Local Flexibility Market(s)
LMO	Local Market Operator
MIQCP	Mixed-Integer Quadratically Constrained Programming
MV	Medium Voltage
MWh	Megawatt-hour
NRMSE	Normalized Root Mean Square Error
OPEX	Operational Expenditures
PV	Photovoltaic
RP	Reactive Power
TOTEX	Total Expenditures
TSO	Transmission System Operator
VOLL	Value of Lost of Load

Indices and Sets

t	Index of time periods
m	Index of representative days
f	Index of FSPs
N_T	Set of time simulation periods
N_L	Set of lines and transformers
N_{LI}	Set of investment candidates lines/transformers
N_S	Set of switchable lines
N_B	Set of electric buses except slack bus
N_{BS}	Set of electrical substations
N_F	Set of FSPs
N_{FD}	Set of FSPs type load
N_{FG}	Set of FSPs type generator
N_M	Set of representative days

Other symbols

n^*	The number of elements of set N, applicable to $N_T, N_L, N_{LI}, N_S, N_B$
$*^T$	Transpose of matrix/vector *
R^n	Real n -vector/matrix
$\{*\}_i$	i -th element of vector *

Parameters

C^{IL}	Annualized cost of building a new line/transformer
$C_{m,t}^{loss}$	Power losses cost
C^{sw}	Switching cost
C^{EENS}	EENS cost
C^{GC}	GC cost
$C_{f,m,t}^{UP}$	Upward flexibility cost (AP)
$C_{f,m,t}^{DP}$	Downward flexibility cost (AP)

$C_{f,m,t}^{UQ}$	Upward flexibility cost (RP)
$C_{f,m,t}^{DQ}$	Downward flexibility cost (RP)
σ_m	Weighting of the representative day m
$R^l, X^l \in R^{n_l}$	Line/transformer resistance, reactance
$A \in R^{n_b \times n_l}$	Reduced incidence matrix
$D \in R^{n_b \times n_f}$	Binary matrix that indicates whether a FSP type load is connected at a bus
$G \in R^{n_b \times n_f}$	Binary matrix that indicates whether a FSP type generator is connected at a bus
α^{LS}	Maximum allowable percentage of load shedding at each bus
$P_{m,t}^{DO} \in R^{n_b}$	Demand at each node (AP)
$Q_{m,t}^{DO} \in R^{n_b}$	Demand at each node (RP)
$P_{m,t}^{GO} \in R^{n_b}$	DG injection at each node (AP)
$Q_{m,t}^{GO} \in R^{n_b}$	DG injection at each node (RP)
$P_{m,t}^{FO} \in R^{n_{fd}}$	FSP initial profile (AP)
$Q_{m,t}^{FO} \in R^{n_{fd}}$	FSP initial profile (RP)
$S_{m,t}^{f-max} \in R^{n_f}$	FSP maximum apparent power
P^{FC}	Power factor correction
$S^{l-max} \in R^{n_l}$	Lines/transformer maximum apparent power
M	Big M
V^{min}, V^{max}	Bus voltage limits
$Z_0 \in R^{n_l}$	Status of line/transformer at period $t = 0$
$\Delta P_{m,t}^{Umax} \in R^{n_f}$	Upward flexibility offer limit (AP)
$\Delta P_{m,t}^{Dmax} \in R^{n_f}$	Downward flexibility offer limit (AP)
$\Delta Q_{m,t}^{Umax} \in R^{n_f}$	Upward flexibility offer limit (RP)
$\Delta Q_{m,t}^{Dmax} \in R^{n_f}$	Downward flexibility offer limit (RP)

Variables

C^I	Total investment cost
C^O	Total operation cost
$u^l \in R^{n_l}$	Status of investment candidate (line/transformer). Binary variable: $u^l = 0$ not built, $u^l = 1$ built.
$p_{m,t}^l \in R^{n_l}$	Active power flow of line/transformer
$q_{m,t}^l \in R^{n_l}$	Reactive power flow of line/transformer
$\gamma_{m,t}^l \in R^{n_l}$	Indication when a line is reconfigured from the period t to $t = t + 1$. Binary variable: $\gamma_{m,t}^l = 1$ if the switch is actuated upon $\gamma_{m,t}^l = 0$
$p_{m,t}^{LS} \in R^{n_b}$	Bus load shedding (AP)
$q_{m,t}^{LS} \in R^{n_b}$	Bus load shedding (RP)
$p_{m,t}^G \in R^{n_b}$	Bus generation dispatched (AP)
$q_{m,t}^G \in R^{n_b}$	Bus generation dispatched (RP)
$\Delta p_{m,t}^U \in R^{n_f}$	Upward flexibility cleared offer (AP)
$\Delta p_{m,t}^D \in R^{n_f}$	Downward flexibility cleared offer (AP)
$\Delta q_{m,t}^U \in R^{n_f}$	Upward flexibility cleared offer (RP)
$\Delta q_{m,t}^D \in R^{n_f}$	Downward flexibility cleared offer (RP)
$z_{m,t}^l \in R^{n_l}$	Status of switchable lines. Binary variable $z_{m,t}^l = 0$ line opened, $z_{m,t}^l = 1$ line closed
$V_{m,t}^{sq} \in R^{n_b}$	Square of the bus voltage magnitude
$s_{m,t}^l \in R^{n_l}$	Auxiliary variable of line l for voltage drop
$k_{m,t}^l \in R^{n_l}$	Fictitious active power flow of line/transformer
$p_{m,t}^F \in R^{n_f}$	FSP (AP) after flexibility procurement
$q_{m,t}^F \in R^{n_f}$	FSP (RP) after flexibility procurement

offers a definition specific to distribution systems, emphasizing that a flexibility solution combines DSO-owned and third-party flexibility resources to address a need in the distribution system by delivering a service. These services include congestion management, voltage control, black start, islanding, or support for network planning.

On the one hand, flexibility resources owned and operated by DSOs for solving congestions include distribution network reconfiguration (DNR), transformer tap-changes, modifying set-points of grid elements, and switching on and off capacitors. Among these resources, the benefits of DNR have been reported extensively in the literature. DNR involves controlling tie and sectionalizing switches to modify the network topology, offering benefits such as power loss minimization [5,6], congestion management and voltage support [7–9], service restoration [10,11], and investment planning support [12,13]. On the other hand, third-party flexibility provided by network users, such as distributed generators (DGs), demand-side response, and energy storage are not owned by DSOs, but DSOs can activate them to procure grid services through flexibility mechanisms. DSOs' flexibility mechanisms can be classified into implicit (network tariffs) and explicit (market-based procurement, flexible connection agreements, and rules-based approaches). The term implicit implies the absence of an explicit commitment to provide a system service [14].

In Europe, the upcoming Network Code for Demand Response, currently under drafting and expected to be adopted by the European Commission in 2025 [15], specifies that market-based solutions are the preferred and by-default solution to procure local network services. In light of this regulatory shift and the growing emphasis on market-based flexibility, this paper focuses on such solutions. Market-based procurement refers to the acquisition of flexibility services through competitive mechanisms, which may include local flexibility markets (LFMs) or competitively awarded bilateral contracts when liquidity is limited.

The upcoming Network Code defines local markets, termed LFMs in this paper, as those that address congestion or voltage issues in the transmission or distribution network within the same bidding zone. LFMs have been the subject of extensive academic and practical interest. Numerous European projects, including EUniversal [16], Coordinet [17], and OneNet [18], have investigated their potential benefits. Furthermore, the academic literature has explored a range of mathematical models that contribute to a comprehensive understanding of LFMs, encompassing aspects such as aggregation [19,20], the incorporation of network constraints in the market-clearing [17,21], the implications when a LFM is operated by a third-party entity [19,22], the utilization of blockchain technologies in LFMs [23], the modeling of LFMs considering capacity limitation services [24], and the analysis of strategic behavior in LFMs [25], among others.

Notably, the locational nature of LFMs implies that only flexibility service providers (FSPs) connected to specific areas of the grid can provide the required service. However, network reconfiguration can alter the grid topology, potentially enabling FSPs in other parts of the network to contribute. In this context, this paper specifically focuses on the coordinated use of DSO-owned flexibility through DNR and third-party flexibility via market mechanisms for congestion management, investigating a critical interaction that has not yet been adequately addressed in distribution network planning models (DNPMS).

1.2. Literature Review and identified research gaps

Although an extensive body of literature has explored the benefits of investment in grid infrastructure, DNR, and procuring of third-party flexibility as individual solutions for mitigating distribution network constraints, limited attention has been devoted to exploring their combined implementation within a unified decision-making framework. For instance, the authors in [26] propose a multistage long-term distribution expansion planning model considering multiple options, such as constructing or reinforcing substations, the construction of circuits, the allocation of capacitor banks, voltage regulators, DGs, and

reconfiguration options. Their results demonstrate that considering multiple expansion alternatives can avoid unnecessary large investments to meet future demand conditions. However, the model does not account for critical DNR-related aspects necessary for practical implementation, such as the switching cost, which promotes the selection of reconfiguration strategies that best balance the operational benefits and the costs incurred during switching actions. Similarly, [12,27] present expansion planning models that incorporate network reconfiguration. Nevertheless, these studies offer only limited integration with third-party flexibility resources and do not consider market-based mechanisms within their frameworks.

Some distribution planning models have also incorporated third-party flexibility resources, particularly through implicit mechanisms, with the impact of demand response (DR) [28–30] being the most extensively investigated. For example, [29] presents a general real options framework under uncertainty that quantifies the economic value of DR against alternative investment strategies and identifies the maximum price at which DR remains economically optimal. This model highlights considering uncertainty is the only way to explicitly quantify and acknowledge the value of flexible solutions such as DR. Another relevant work is [30], where authors propose a coordinated DNPMS with network reconfiguration and DR showing that this integrating model can decrease and postpone some parts of the expansion requirements.

In contrast, relatively few works have proposed DNPMS using explicit flexibility mechanisms. One example is [31], where a comprehensive evaluation of the economic value of flexibility is carried out. Flexible connections, markets, or bilateral agreements for acquiring flexibility are compared with traditional solutions, such as network reinforcements or load shedding, through a cost-benefit analysis. Furthermore, [3] introduces a hybrid particle swarm optimization and linear programming methodology integrating a market-based flexibility procurement in a DNPMS. This shows that flexibility could be a cost-effective alternative to defer or avoid part of the required network reinforcements. However, neither [31] nor [3] capture the dynamic impacts of network reconfiguration on flexibility provision and market participation. On the other hand, [13] presents a multistage planning strategy to minimize the distribution system cost in contingency situations (N-1 and N-2). The algorithm decides the optimal investment in tie-lines and, for every contingency, the optimal network reconfiguration given the available tie-lines. In addition, this proposal models FSPs' cost and delivery, but no flexibility market-clearing or bid-based procurement process are included.

Recent studies, such as [9] and [4], have focused on short-term congestion management using DNR and LFMs, without addressing long-term planning or investment decisions. For instance, a comprehensive day-ahead congestion management scheme combining DNR and flexibility markets is proposed in [9]. First, the DSO calculates the optimal topology of the network and distribution locational marginal prices (DLMPs). Based on these DLMPs, Aggregators generate bids for the day-ahead wholesale market, and if congestions persist, flexibility is procured through an LFM. Simulation results show that the proposed solution can utilize the flexibility provided by different resources to solve congestion and ensure that customers do not face very high DLMPs. Furthermore, it was demonstrated that the network reconfiguration could be used to avoid the infeasibilities of the DNR-based DSO optimization problem. Our previous work [4] proposed a conceptual framework for the interaction between DNR and LFM for congestion management. This approach was analyzed from two perspectives, when a DSO operates the LFM and when this market is operated by a third party (independent market operator). The main difference between both approaches is how the grid parameters are considered in the market clearing, i.e., a full grid representation is used when the DSO is the market operator, and by contrast, a simplified representation of the network is shared by the DSO to the independent market operator since this kind of information is sensitive.

To synthesize the insights from the reviewed literature, Table 1

Table 1
Comparative Analysis of Models Integrating Investment, Reconfiguration, and/or Third-party Flexibility.

Ref.	Joint INV-DNR-FSP ^a model	Model Objective: Congestion Management	Grid Topology / FSPs eligibility	Cost Structure	Sensitivity Analysis
[26] (2016)	x (INV + DNR + Other DSO-owned flexibility resources)	Indirect (Via expansion planning)	x	✓ CAPEX (Lines/transformers, voltage regulators, capacitor banks), ✓ OPEX (Power losses, substations operations)	✓ Combinations of different expansion alternatives
[30] (2015)	x (INV + DNR + Demand Response-DR)	Indirect (Via expansion planning)	x	✓ CAPEX (lines), ✓ OPEX (Power losses, Imported energy, DR, Reliability)	✓ Combinations of scenarios between DR, DNR and/or uncertainty
[31] (2023)	x (INV + LFM and other mechanisms to procure flexibility from third parties)	✓ Explicit objective (Cost-benefit analysis)	x	✓ CAPEX (Enabling costs for the use of flexibility), ✓ OPEX (Availability and Activation payments for flexibility services)	✓ Comparison of business-as-usual solutions (network reinforcements, load shedding) vs Flexibility solutions
[3] (2024)	x (INV + LFM)	Indirect (Via reinforcement planning)	x	✓ CAPEX (Network reinforcements), ✓ OPEX (LFM Flexibility)	✓ Flexibility providers' capacity and bidding cost
[13] (2023)	x (INV + DNR + Flexibility services)	Partial (Post-Failure Contingency)	x	✓ CAPEX (Lines), ✓ OPEX (DNR Switching, FSPs payments, EENS)	✓ Load growth ✓ Contingency scenarios
[9] (2019)	x (DNR + LFM + Dynamic Tariffs (DT))	✓ Explicit objective	x	✓ OPEX (Short-term Day-ahead costs: Power losses, Charging of electric vehicles and heat pumps)	✓ Combinations of scenarios between DNR and DT
[4] (2023)	x (DNR + LFM) conceptual	✓ Explicit objective	x	x Not quantified	x Not quantified
This paper	✓ (INV + DNR + FSP) First unified co-optimization model combining all three	✓ Explicit objective	✓ Full network model, DSO as LFM operator	✓ CAPEX (New lines/transformers), ✓ OPEX (DNR switching, LFM Flexibility, Power losses, EENS, Generation Curtailment)	✓ Load growth ✓ FSP's capacity and bidding cost ✓ Weighting of representative days ✓ Combinations between INV, DNR, and/or LFM

^a INV-DNR-FSP refers to the joint optimisation of investment (INV), distribution network reconfiguration (DNR), and market-based procurement of services from third-party Flexibility Service Providers (FSPs) for congestion management.

provides a structured comparison of the main characteristics of the existing models across five key dimensions. The first dimension assesses whether the models jointly optimize INV, DNR, and the market-based procurement of third-party flexibility within a unified framework. The second dimension examines whether congestion management is explicitly addressed as the primary planning objective rather than treated as a secondary outcome of planning decisions. The third dimension evaluates whether the models capture the interaction between grid topology and the participation of FSPs, considering how reconfiguration can influence market eligibility. The fourth dimension analyses the cost structure's comprehensiveness, specifically whether capital expenditures (CAPEX) and operational expenditures (OPEX) are incorporated into the optimization framework. Finally, the fifth dimension reviews the extent to which the models conduct sensitivity analyses to test their performance under different scenarios.

Despite the breadth of approaches reviewed, none of the existing models simultaneously co-optimizes investment, grid reconfiguration, and the market-based procurement of third-party flexibility for congestion management. While several models address individual alternatives or partial combinations thereof, significant gaps remain. Notably, existing planning models integrating flexibility procurement typically do not account for dynamic grid topology changes, often assuming static eligibility of flexibility providers. Consequently, they fail to represent how DNR can dynamically alter the flexibility market participation and competition. Moreover, no existing DNPMS fully align with the evolving European regulatory framework, which prioritizes market-based procurement of local services unless proven inefficient.

1.3. Research contributions

In light of the identified gaps, the contributions of this paper are fourfold:

- **A unified optimization model** that integrates grid investment, network reconfiguration, and the market-based procurement of third-party flexibility within a coordinated congestion management strategy. These approaches differ in cost structure, implementation timeline, and regulatory context, but they are captured within a common decision-making framework to support DSOs in making informed and cost-effective decisions regarding congestion management.
- **An explicit representation and analysis of the interaction between network reconfiguration and third-party flexibility**, showing how changes in network topology affect the geographic eligibility and participation of flexibility providers.
- **A cost-reflective planning framework**, that combines capital and operational expenditures, reflecting the balance between traditional grid reinforcement and the use of operational flexibility. To ensure tractability in long-term planning, operational costs are evaluated using representative days, including extreme demand conditions. This approach maintains both computational efficiency and modeling accuracy.
- **An empirical evaluation through a detailed case study**, examining key sensitivities such as load growth, flexibility capacity and cost, and the weighting assigned to representative days. The analysis highlights the trade-offs among network investment, reconfiguration, and third-party flexibility procurement, demonstrating how these strategies interact and underscoring the importance of aligning traditional distribution planning with operational flexibility for effective congestion management.

1.4. Reading map

The rest of the paper is organized as follows. [Section 2](#) describes the proposed INV-DNR-FSP modeling framework. [Section 3](#) provides a detailed overview of the case study, which is evaluated under different sensitivities. [Section 4](#) discusses key insights and future research

directions, and Section 5 presents the main conclusions.

2. Modeling framework for co-optimizing Investment, distribution network reconfiguration and third-party flexibility (INV-DNR-FSP)

This section presents a four-step modeling framework for co-optimizing investment, DNR, and the market-based procurement of third-party flexibility to manage forecasted congestions in distribution networks. The model considers a DSO facing grid element overloads or voltage violations over a one-year horizon, with three alternative strategies: investing in new lines or transformers parallel to congested elements, applying DNR, and/or procuring flexibility from third-party resources. The proposed framework, outlined in Fig. 1, captures the dynamics and interactions among these options, with each step detailed in the following subsections.

2.1. Step 1: Representative days selection

Managing hourly demand and generation profiles over a full year represents a significant challenge for the proposed INV-DNR-FSP model. This complexity is further exacerbated by the large number of binary variables required to represent network reconfiguration and investment decisions. Additionally, the model must effectively capture the dynamics of DNR and third-party flexibility. Consequently, a trade-off is required between achieving a high level of accuracy, preserving the tractability of the resulting optimization problem, and effectively capturing the value of flexibility integration in the planning model.

Representative periods with similar load and renewable generation levels are commonly utilized to address computational challenges in long-term planning models, as shown in [32,33]. Selecting representative periods enables models to capture typical conditions for peak and off-peak demands and renewable generation patterns. The existing literature offers multiple approaches for selecting representative days [33], including simple heuristics, clustering algorithms, optimization-based, or hybrid approaches.

Furthermore, the selected representative days must be sufficiently

robust to capture the value of network reconfiguration and local flexibility markets. Firstly, hourly representative days are required to assess the impact of this operational flexibility effectively. In the case of DNR, hourly switching operation costs are explicitly modeled. These costs promote the selection of reconfiguration strategies that balance operational benefits while avoiding excessive switching actions. Similarly, hourly representative days are crucial for accurately modeling third-party flexibility implications, given that flexibility activation prices and asset dispatch are inherently hourly processes. For instance, the flexibility activation price is intrinsically tied to the opportunity cost of participating in the wholesale markets, batteries, and other flexibility resources operate optimally on an hourly basis, and DSO flexibility needs are generally assessed by analyzing hourly congested problems and voltage violations [17].

Moreover, the selection of representative days must account for extreme conditions in the distribution system, which can be identified by calculating the net demand at the slack bus of the network. Net demand is critical for calculating flexibility needs, as it directly informs to the DSO about the magnitude and direction of required flexibility. Third-party flexibility is typically procured in two directions: upward (e.g., increased generation or decreased consumption) and downward (e.g., decreased generation or increased consumption) flexibility bids. Given this context, Fig. 1 outlines a procedure for selecting representative days for the INV-DNR-FSP model, which is further detailed below.

- i) **Power flow calculations:** Considering the input profiles (i.e., one year of hourly data for demand, as well as PV and wind generation profiles) and the distribution network topology and parameters, a power flow analysis is performed using the Pandapower toolbox [34] to obtain the net demand at the slack bus. Then, the hourly net demand is averaged for each day of the year to derive the daily net demand, which is needed to select representative days.
- ii) **Applying the clustering algorithm and choosing representative days:** A clustering analysis was performed using the k-Medoids technique [35] to identify days that exhibit typical net demand patterns for each year's season. Days grouped within the

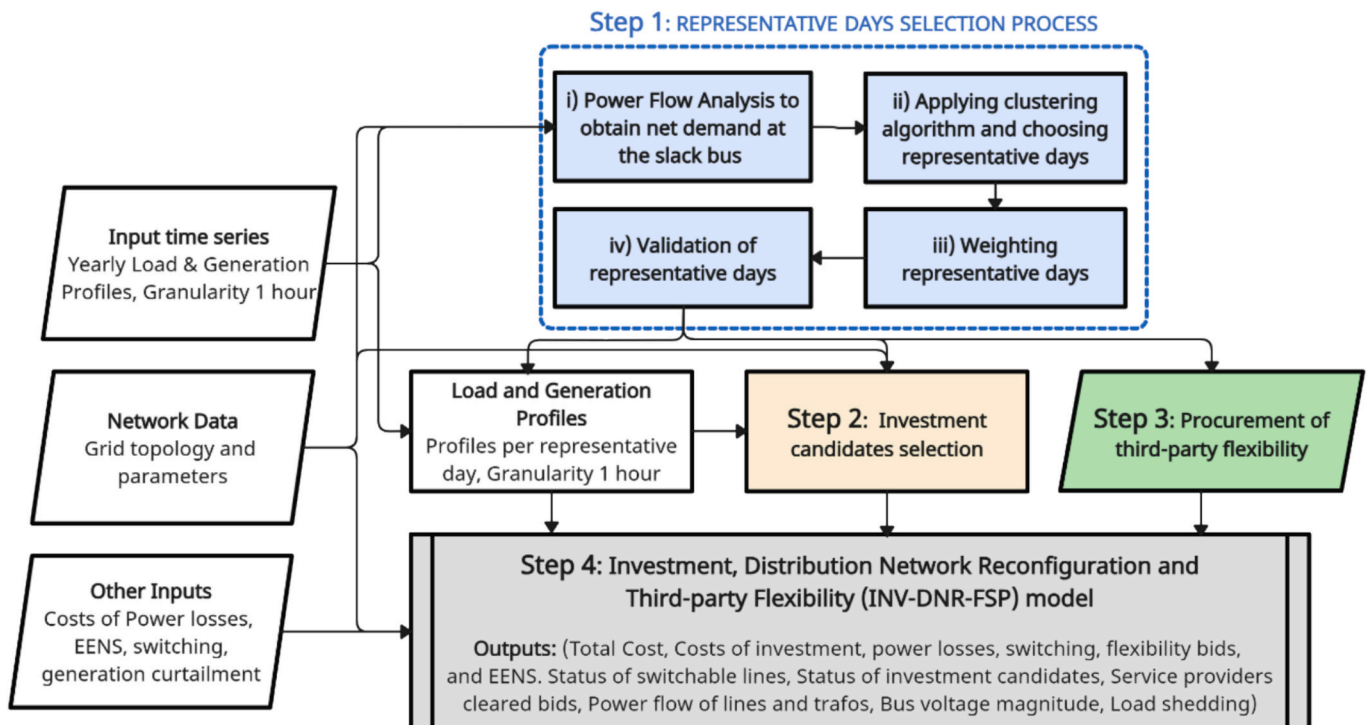

Fig. 1. A modelling framework for evaluating the interaction among Investment, Distribution Network Reconfiguration and Third-party Flexibility (INV-DNR-FSP).

same cluster will be represented by the same representative day in the INV-DNR-FSP model. Therefore, the clusters' centroids are selected as representative days, as they contain the mean values of net demand for each season. Additionally, to account for extreme conditions, the days with the maximum and minimum hourly net demand throughout the year are also included as representative days.

- iii) **Weighting representative days:** The next step involves weighting the six selected representative days. First, to weigh the two extreme condition days, we identify the hours within $\pm 1\%$ of the maximum and minimum net demand values. The number of days containing these critical hours is then used as the weight of the days with extreme conditions. Subsequently, the representative days for each season are weighted based on a factor that reflects the relative size of their respective cluster, adjusted by subtracting the weights of extreme condition days.
- iv) **Validation:** A comparison between the load duration curves (LDC) derived from the entire year's data (original) and the selected representative days (approximated) is carried out. The average normalized root-mean-square error (NRMSE) [33] is used as a metric to evaluate the accuracy of approximation.

2.2. Step 2: Investment candidates selection

The selection of investment candidates is based on a power flow analysis, using demand and generation profiles derived from the six representative days obtained in Step 1. This analysis identifies critical bottlenecks, such as overloaded lines or transformers, and areas with voltage issues. Initially, all congested lines or transformers are considered potential investment options. However, the operational behavior of lines is further assessed using a distribution network reconfiguration model developed in our previous work [36]. Congested lines that frequently change status during the DNR model are excluded as investment candidates, as their congested issues may be better addressed through reconfiguration strategies. Consequently, the final investment candidates are limited to parallel lines or transformers to congested elements that do not change their status in the DNR model.

2.3. Step 3: Procurement of third-party flexibility

The proposed INV-DNR-FSP model considers that a DSO can procure local flexibility services from third-party FSPs to mitigate forecasted grid constraints and/or delay the need for traditional grid reinforcements. These services are modelled as upward and downward flexibility offers in terms of active or reactive power, available in predefined quantities, prices, and locations.

This proposal is agnostic to the specific flexibility procurement mechanism. Rather than simulating the full flexibility procurement process (i.e., prequalification, bidding, clearing, activation, and settlement), the model focuses on selecting the most cost-effective combination of flexibility offers to resolve network constraints. This abstraction allows the model to accommodate offers arising from any market-based arrangement (e.g., local flexibility markets or bilateral contracts), and it could even be adapted to other explicit flexibility mechanisms [14]. In practice, the choice of a procurement mechanism will depend on the regulatory framework applicable in each jurisdiction.

In this study, the DSO is assumed to act as the procuring entity with full access to grid data. This scenario enables the formulation of a unified optimization problem (see Step 4) that incorporates a full network representation, including investment, DNR, and third-party flexibility procurement. Table 2 summarizes the main characteristics of third-party flexibility products and the procurement context considered in this work. Flexibility services can be provided by a generator, storage or demand assets, either individually or through aggregators. Further details on the product dimensions are provided in [37].

Table 2

Third-party flexibility procurement: Product and implementation characteristics.

A: Service/Product Dimension	Characteristics
Service	Congestion Management
Service objective	To mitigate and/or delay the need for traditional grid reinforcements
System operator needs	Planned
Transactional object	Availability and Activation
Power	Active and Reactive Power
Direction of activation	Upwards and Downwards
Location information required	Yes
B: Implementation Context Dimension	Characteristics
Procurement flexibility mechanism	Market-based (via local flexibility markets or bilateral contracts)
Procuring entity	DSO
Service provider	Aggregators or Individual providers
Negotiation time frame	Long-term
Delivery time frame	Hourly
Grid constraint representation	Comprehensive grid data

2.4. Step 4: Multi-option optimization model

Building on the preceding steps of the proposed modeling framework, this subsection formulates a Mixed-Integer Quadratically Constrained Programming (MIQCP) model, featuring a quadratic objective and both linear and quadratic constraints that jointly optimizes INV-DNR-FSP. The formulation is developed under the following assumptions:

- The optimization problem is formulated in terms of matrices and vectors, following the nomenclature section of this paper.
- As previously stated, we consider a DSO aiming to mitigate congestion constraints that are expected to occur at the base load and generation profiles specified for the six representative days. The model incorporates a full network representation, reflecting the assumption that the procuring DSO acts as the LFM operator.
- The electricity distribution system operates in steady-state and balanced conditions and is represented by a single-phase equivalent.
- The proposed model considers decision variables in two different time scales: investment and operation. Operational costs are computed for the six representative days, which simulate a full year of operations.
- A deterministic single-stage approach is adopted for the distribution network planning problem.
- Power and voltage quantities are expressed in the per-unit system.
- *Objective function*

Electricity distribution is a regulated monopoly, requiring regulation that defines the DSO remuneration schemes and economic incentives. The regulated costs that the distribution company must cover are: grid infrastructure investment costs, operating and maintenance costs, and other costs related to customer services and other corporate costs [38]. Additionally, distribution companies should reduce network power losses, and they must receive an incentive to reduce them. Furthermore, the distributor may also be penalized or credited according to the actual quality of supply [38].

Within this context, the proposed INV-DNR-FSP model aims to minimize the expected total cost of the distribution system, as formulated in equation (1). This cost includes the costs of investments (C^I) and system operation (C^O) as shown in equations (2) and (3), respectively. C^I represents the annualized cost of building new distribution lines and transformers. C^O considers six cost components, as outlined in (3): i) network power losses cost, ii) switching cost related to network

reconfiguration, costs associated with the quality of supply including iii) cost of the expected energy not-supplied (EENS), and iv) generation curtailment cost, and the flexibility procurement cost in terms of active power v) and reactive power vi). The components i)-vi) of the operation cost are multiplied by the factor σ_m to make them comparable with investment cost, where σ_m is the number of times that the representative day m is repeated within a year. Overall, the model follows a TOTEX-based optimisation framework, co-optimizing capital and operational expenditures to identify the most cost-effective combination between network investment, reconfiguration, and third-party flexibility procurement.

$$\min_x [C^l + C^o] \quad (1)$$

$$C^l = \sum_{ij=1}^{n_L} \{C^{LL}\}_{ij} \{u^l\}_{ij} \quad (2)$$

$$Ap_{m,t}^l = \left[P_{m,t}^{D0} + D \left(-\Delta p_{m,t}^U + \Delta p_{m,t}^D \right) - P_{m,t}^{LS} \right] - \left[p_{m,t}^G + G \left(\Delta p_{m,t}^U - \Delta p_{m,t}^D \right) \right], \forall t \in NT, \forall m \in NM \quad (6)$$

$$Aq_{m,t}^l = \left[Q_{m,t}^{D0} + D \left(-\Delta q_{m,t}^U + \Delta q_{m,t}^D \right) - q_{m,t}^{LS} \right] - \left[q_{m,t}^G + G \left(\Delta q_{m,t}^U - \Delta q_{m,t}^D \right) \right], \forall t \in NT, \forall m \in NM \quad (7)$$

$$0 \leq p_{m,t}^{LS} \leq \alpha^{LS} P_{m,t}^{D0}, \forall t \in NT, \forall m \in NM \quad (8)$$

$$\{q_{m,t}^{LS}\}_i = \left(\{Q_{m,t}^{D0}\}_i / \{P_{m,t}^{D0}\}_i \right) \{P_{m,t}^{LS}\}_i, \forall t \in NT, \forall m \in NM, \forall i \in NB / NB_{stack} \quad (9)$$

$$0 \leq p_{m,t}^G \leq P_{m,t}^{G0}, \forall t \in NT, \forall m \in NM \quad (10)$$

$$\{q_{m,t}^G\}_i = \left(\{Q_{m,t}^{G0}\}_i / \{P_{m,t}^{G0}\}_i \right) \{P_{m,t}^G\}_i, \forall t \in NT, \forall m \in NM, \forall i \in NB / NB_{stack} \quad (11)$$

$$C^o = \sum_{m=1}^{n_M} \sigma_m \sum_{t=1}^{n_T} \left[\begin{aligned} & C_{m,t}^{LOSS} \sum_{ij=1}^{n_L} \{R^l\}_{ij} \left(\{p_{m,t}^l\}_{ij}^2 + \{q_{m,t}^l\}_{ij}^2 \right) \\ & + C^{sw} \sum_{ij=1}^{n_L} \{v_{m,t}^l\}_{ij} + C^{EENS} \sum_{i=1}^{n_B} \{P_{m,t}^{LS}\}_i + C^{GC} \sum_{i=1}^{n_B} \{P_{m,t}^{G0} - p_{m,t}^G\}_i \\ & + \sum_f^{n_F} \left(C_{f,m,t}^{UP} \{ \Delta p_{m,t}^U \}_f + C_{f,m,t}^{DP} \{ \Delta p_{m,t}^D \}_f \right) \\ & + \sum_f^{n_F} \left(C_{f,m,t}^{UQ} \{ \Delta q_{m,t}^U \}_f + C_{f,m,t}^{DQ} \{ \Delta q_{m,t}^D \}_f \right) \end{aligned} \right] \quad (3)$$

• Constraints

The objective function is subject to six groups of constraints, which are described below.

i) Investment constraints: Constraints (4) define binary variables u^l that indicate whether a parallel prospective line ij is built ($\{u^l\}_{ij} = 1$) or not ($\{u^l\}_{ij} = 0$), this applies for the set of candidate lines for investment (NLI). For all other lines $\{u^l\}_{ij} = 0$ as indicated in the equation (5).

$$\{u^l\}_{ij} = \{0, 1\}, \forall ij \in NLI \quad (4)$$

$$\{u^l\}_{ij} = 0, \forall ij \in NL \setminus NLI \quad (5)$$

ii) Power balance constraints: Linear DistFlow equations [39] are considered as power flow constraints for the proposed model. Constraints (6) and (7) specify the requirement for load balance across non-substation nodes for active and reactive power. Here, $\Delta p_{m,t}^U$, $\Delta q_{m,t}^U$ and $\Delta p_{m,t}^D$, $\Delta q_{m,t}^D$ denote the upward and downward flexibility provided by FSPs. The D and G binary matrices indicate whether a FSP type load or generation is connected at a distribution node, respectively. Moreover, (8) ensures that load shedding cannot be negative and cannot exceed actual demand, while (9) relates the active and reactive power load shedding at each node. Similarly, constraint (10) ensures that the generation curtailment does not exceed production, and (11) relates the active and reactive power curtailment at each node.

iii) Power flow limits: Constraints (12)-(19) impose limits on line loading and bus voltage considering the impact of network reconfiguration and investment decisions. Network reconfiguration is integrated into the model through a binary variable that reflects the state of the lines in each optimization period ($z_{m,t}^l = 0$, i.e., line opened,), ($z_{m,t}^l = 1$, i.e., line closed). Here, constraint (13) forces the active and reactive line power flow to be zero if the corresponding switch is open. Similarly, these limits are also zero when a candidate investment line is not built, as specified in (14). Constraints (16)-(18) formulate the voltage drop along line (i, j) , where (17) and (18) ensure the voltage drop constraint (16) to be nonbinding when the line is open.

$$\left| \{p_{m,t}^l\}_{ij} \right| \leq P^{FC} \{S^{l-max}\}_{ij}, \forall t \in NT, \forall m \in NM, \forall ij \in NL \quad (12)$$

$$\left| \{p_{m,t}^l\}_{ij} \right| \leq M \{z_{m,t}^l\}_{ij}, \left| \{q_{m,t}^l\}_{ij} \right| \leq M \{z_{m,t}^l\}_{ij}, \forall t \in NT, \forall m \in NM, \forall ij \in NL / NLI \quad (13)$$

$$\left| \{p_{m,t}^l\}_{ij} \right| \leq M \{u^l\}_{ij}, \left| \{q_{m,t}^l\}_{ij} \right| \leq M \{u^l\}_{ij}, \forall t \in NT, \forall m \in NM, \forall ij \in NLI \quad (14)$$

$$(V^{min})^2 \leq v_{m,t}^{sq} \leq (V^{max})^2, \forall t \in NT, \forall m \in NM \quad (15)$$

$$\{v_{m,t}^{sq}\}_i - \{v_{m,t}^{sq}\}_j = 2 \left(\{R^l\}_{ij} \{p_{m,t}^l\}_{ij} + \{X^l\}_{ij} \{q_{m,t}^l\}_{ij} \right) + \{s_{m,t}^l\}_{ij}, \forall t \in NT, \forall m \in NM, \forall ij \in NL \quad (16)$$

$$\left| \left\{ s_{m,t}^l \right\}_{ij} \right| \leq M \left(1 - \left\{ z_{m,t}^l \right\}_{ij} \right), \forall t \in NT, \forall m \in NM, \forall ij \in NL / NLI \quad (17)$$

$$\left| \left\{ s_{m,t}^l \right\}_{ij} \right| \leq M \left(1 - \left\{ u^l \right\}_{ij} \right), \forall t \in NT, \forall m \in NM, \forall ij \in NLI \quad (18)$$

$$\left\{ v_{m,t}^{gr} \right\}_i = 1, \forall i \in NB_{slack}, \forall t \in NT, \forall m \in NM \quad (19)$$

iv) Topological constraints: Topological constraints provide sufficient conditions to ensure a radial network topology when considering DNR. As stated in [40], a network with n_B nodes and n_{BS} substation nodes is radial if it satisfies two conditions: i) the solution must have $(n_B - n_{BS} + n_{LI})$ circuits, which is expressed in (20) and ii) the solution must be connected, which is fulfilled by (6), (7), (21), and (22). Constraints (21) and (22) are added to guarantee that the network must remain radial and no isolated buses are allowed after switching. Therefore, all buses must remain connected to the slack bus by supplying a unit of fictitious active power $k_{m,t}^l$. This fictitious power is zero when the corresponding switch is open [9].

$$\sum_{ij=1}^{n_L} \left\{ z_{m,t}^l \right\}_{ij} = n_B - n_{BS} + n_{LI}, \forall t \in NT, \forall m \in NM \quad (20)$$

$$A k_{m,t}^l = 1, \forall t \in NT, \forall m \in NM \quad (21)$$

$$\left| \left\{ k_{m,t}^l \right\}_{ij} \right| \leq M \left\{ z_{m,t}^l \right\}_{ij}, \forall ij \in NS; \forall t \in NT, \forall m \in NM \quad (22)$$

v) Switching operation constraints: Given that the switching cost is included in the objective function, a new binary variable ($\gamma_{m,t}^l$) is introduced to calculate the number of switching operations according to equations (23) and (24). These constraints force the reconfiguration problem to be solved simultaneously for all hours rather than independently for each hour. However, it is essential to acknowledge that introducing binary variables and big-M constraints adds computational complexity to the model. In order to effectively solve this model for large-scale systems, we segment the lines into two distinct sets. The first set comprises switchable lines for DNR, denoted as NS , while the second set (non-switchable lines) encompasses lines whose statuses (on/off) are predetermined prior to executing the optimization model, as outlined in constraint (25).

$$\gamma_{m,t}^l \geq \left| z_{m,t}^l - z_{m,t-1}^l \right|, \forall t \in NT \setminus \{0\}, \forall m \in NM \quad (23)$$

$$\gamma_{m,t}^l \geq \left| z_{m,t}^l - z_0^l \right|, \forall t \in \{0\}, \forall m \in NM \quad (24)$$

$$\left\{ z_{m,t}^l \right\}_{ij} = z_0^l, \forall t \in NT, \forall m \in NM, \forall ij \in NL / NS \quad (25)$$

$$\left\{ z_{m,t}^l \right\}_{ij} = 1, \forall t \in NT, \forall m \in NM, \forall ij \in NLI \quad (26)$$

$$z_{m,t}^l, \gamma_{m,t}^l = \{0, 1\}, \forall t \in NT, \forall m \in NM \quad (27)$$

vi) Flexibility service providers constraints: Constraints (28)-(31) capture the limits of the submitted upwards and downwards flexibility bids in terms of active and reactive power. Additionally, constraints (32)-(37) represent the capacity limits of service providers, including the procured flexibility. It is important to note that, according to constraint (37), the power factor of each FSP is preserved. This means that when an amount of active power flexibility is procured, a proportional amount of reactive power is also procured to maintain the original power factor.

$$0 \leq \Delta P_{m,t}^U \leq \Delta P_{m,t}^{Umax}, \forall t \in NT, \forall m \in NM \quad (28)$$

$$0 \leq \Delta P_{m,t}^D \leq \Delta P_{m,t}^{Dmax}, \forall t \in NT, \forall m \in NM \quad (29)$$

$$0 \leq \Delta Q_{m,t}^U \leq \Delta Q_{m,t}^{Umax}, \forall t \in NT, \forall m \in NM \quad (30)$$

$$0 \leq \Delta Q_{m,t}^D \leq \Delta Q_{m,t}^{Dmax}, \forall t \in NT, \forall m \in NM \quad (31)$$

$$\left\{ P_{m,t}^F \right\}_f = \left\{ P_{m,t}^{F0} \right\}_f - \left\{ \Delta P_{m,t}^U \right\}_f + \left\{ \Delta P_{m,t}^D \right\}_f, \forall t \in NT, \forall m \in NM, \forall f \in NFD \quad (32)$$

$$\left\{ Q_{m,t}^F \right\}_f = \left\{ Q_{m,t}^{F0} \right\}_f - \left\{ \Delta Q_{m,t}^U \right\}_f + \left\{ \Delta Q_{m,t}^D \right\}_f, \forall t \in NT, \forall m \in NM, \forall f \in NFD \quad (33)$$

$$\left\{ P_{m,t}^F \right\}_f = \left\{ P_{m,t}^{F0} \right\}_f + \left\{ \Delta P_{m,t}^U \right\}_f - \left\{ \Delta P_{m,t}^D \right\}_f, \forall t \in NT, \forall m \in NM, \forall f \in NFG \quad (34)$$

$$\left\{ Q_{m,t}^F \right\}_f = \left\{ Q_{m,t}^{F0} \right\}_f + \left\{ \Delta Q_{m,t}^U \right\}_f - \left\{ \Delta Q_{m,t}^D \right\}_f, \forall t \in NT, \forall m \in NM, \forall f \in NFG \quad (35)$$

$$\left\{ P_{m,t}^F \right\}_f^2 + \left\{ Q_{m,t}^F \right\}_f^2 \leq \left\{ S_{m,t}^{F-max} \right\}_f, \forall t \in NT, \forall m \in NM, \forall f \in NF \quad (36)$$

$$\left\{ Q_{m,t}^F \right\}_f = \left(\left\{ Q_{m,t}^{F0} \right\}_f / \left\{ P_{m,t}^{F0} \right\}_f \right) \left\{ P_{m,t}^F \right\}_f, \forall t \in NT, \forall m \in NM, \forall f \in NFD \quad (37)$$

3. Case Study, Results, and sensitivity analyses

This section provides an overview of the case study and the results of testing the INV-DNR-FSP interaction model. It begins by describing the case study and the input data required for the model, including the selection of representative days, investment candidates, and FSPs bids derived following Steps 1–3 of the framework previously outlined. The discussion then focuses on the results obtained from testing the INV-DNR-FSP model (Step 4). Subsequently, sensitivity analyses are conducted to highlight the advantages and robustness of the proposed model.

3.1. Case Study: Input data

- *Distribution network data*

A 15-bus CIGRE distribution network was selected as a case study to validate the effectiveness of the proposed model. As shown in Fig. 2, this is a 20 kV medium voltage (MV) network with an original topology consisting of 15 lines, including 3 tie switches and 12 sectionalizing switches. All lines are assumed to have remote-controlled switches, classifying them as switchable lines in the model. The detailed data of the load points (industrial and residential customers), generators, transformers and line parameters can be found in [41].

- *Representative days selection*

To model the annual operation of the selected distribution system, six representative days were identified following the framework outlined in Step 1 of Section 2. Hourly data for demand and PV and wind generation profiles were collected for 2019 from the Spanish Transmission System Operator database [42]. Based on these input profiles and the 15-bus distribution network, Table 3 shows the resulting six representative days and their corresponding weights. Furthermore,

Fig. 3 illustrates the hourly net demand for each representative day, revealing that the hours with the highest net demand occur on the maximum net demand, summer, and winter days. By contrast, the hours with the lowest net demand are observed on the minimum net demand, spring, and autumn representative days. A comparison between the LDC curves derived from the entire year's data (original) and the selected representative days (approximated) was carried out, as illustrated in Fig. 4. The NRMSE between the original and the approximated curves was calculated to be 4.25 %.

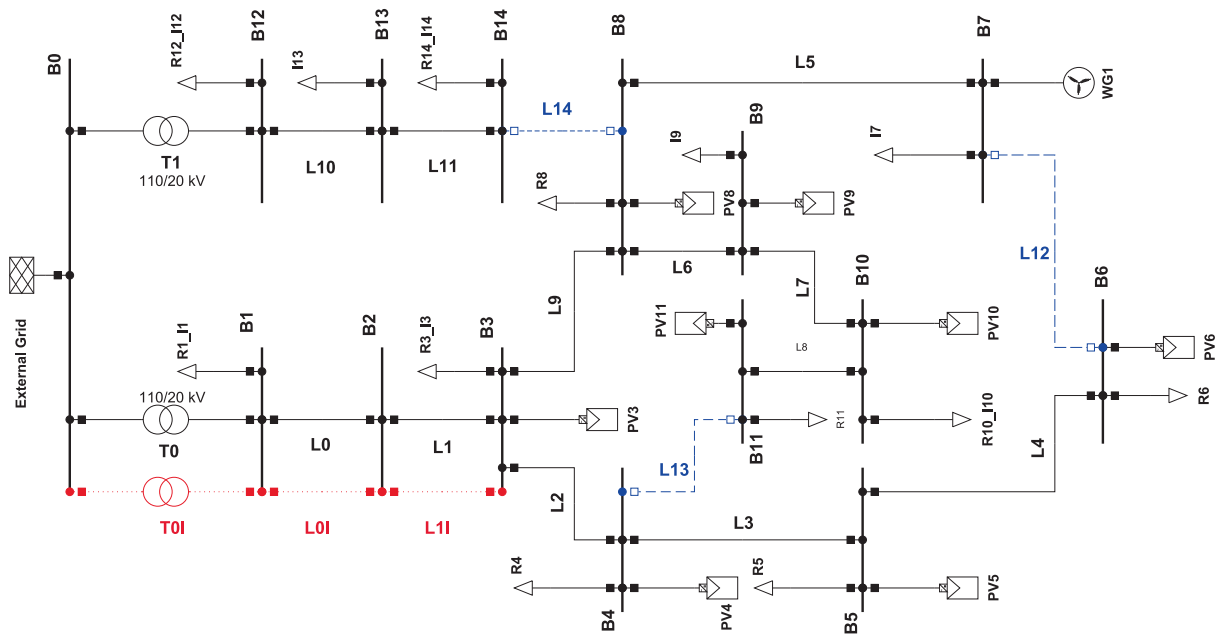

Fig. 2. Single line diagram of the 15-Bus system adapted from [41]. Black lines show the usual operation topology, blue lines are normally open, and red lines are candidates for investment. (For interpretation of the references to colour in this figure legend, the reader is referred to the web version of this article.)

Table 3
Resulting Representative days.

Representative day	Date	Weights NRMSE: 4.25 %
Maximum net demand	2019-01-08	4
Minimum net demand	2019-11-03	2
Spring day	2019-04-17	92
Summer day	2019-07-16	90
Autumn day	2019-10-14	88
Winter day	2019-01-12	89

• Investment Candidates

Following the framework outlined in Step 2 of Section 2 and considering the generation and load profiles obtained in the previous subsection, a set of investment candidates was identified (Table 4). This

analysis revealed that the transformer T0 and lines L0 and L1 experience overloading as demand escalates. For instance, when the demand is increased by a factor of 1.3, T0 is overloaded for 15 h during the maximum net demand, 8 h during the summer, and 3 h during the winter. Similarly, lines L0 and L1 are congested for 4 h on the day of maximum net demand. To further assess the viability of investment in these elements, a DNR model was tested under the same conditions. This evaluation aimed to determine whether the congested lines frequently change status in the DNR model, which could influence their suitability as investment candidates. The results indicate that the status of lines L0 and L1 remains unchanged. Therefore, potential investment options include adding parallel lines/transformers to T0, L0, and L1 elements, as illustrated in the single diagram of Fig. 2. Furthermore, Table 4 provides detailed investment costs for these elements, with annuitized costs calculated based on the initial investment costs, expected life, and a discount rate as defined by the Spanish regulation in [43].

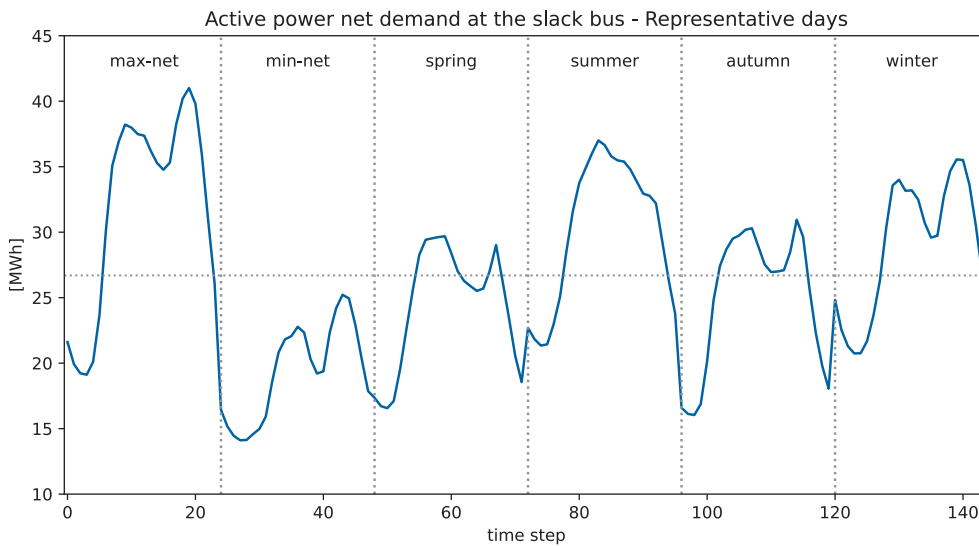

Fig. 3. Active power net demand at the slack bus for each representative day.

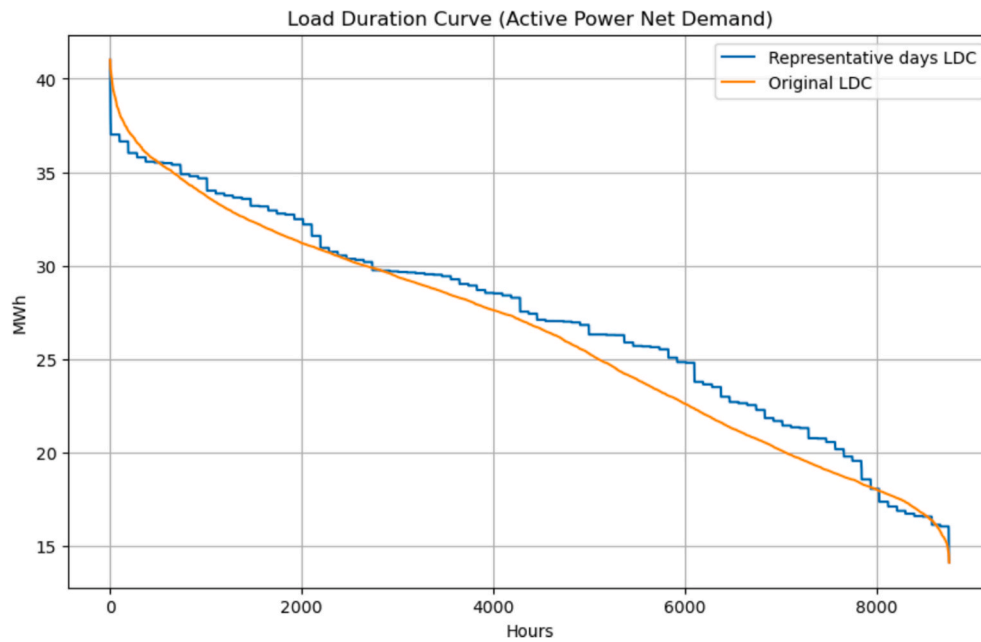

Fig. 4. Representative days validation. The average normalized root-mean-square error (NRMSE) between the original and approximated LDC curves is 4.25%.

Table 4
Candidates for investment data.

Name	From bus	To bus	Investment cost	Investment cost [EUR]	Expected Life [years]	Discount rate	Annuitized Cost [EUR/year]
Transformer T01	0	1	19,367 EUR/MVA	484175.00	40	5.58 %	30491.64
Line L01	1	2	118,212 EUR/km	333357.84	40	5.58 %	20993.70
Line L11	2	3	118,212 EUR/km	522497.04	40	5.58 %	32905.03

• Flexibility service providers' information

Considering the LFM characteristics and products defined in Step 3 of Section 2, it has been assumed that all consumers and generators of the 15-Bus network can provide flexibility services. Therefore, there are 27

FSPs according to the data presented in Table 5. These FSPs offer upward and downward flexibility bids quantified as a percentage of their base profile. The percentages are indicated in the columns "P_up" and "P_down" for active power and "Q_up" and "Q_down" for reactive power. In terms of bid pricing, the 2019 day-ahead market price from

Table 5
Flexibility service providers' information.

Id	Bus	Type	MVA	PF	P_up	P_down	Q_up	Q_down
Fsp0	3	Generator	0.02	1	0 %	10 %	0 %	0 %
Fsp1	4	Generator	0.02	1	0 %	10 %	0 %	0 %
Fsp2	5	Generator	0.03	1	0 %	10 %	0 %	0 %
Fsp3	6	Generator	0.03	1	0 %	10 %	0 %	0 %
Fsp4	8	Generator	0.03	1	0 %	10 %	0 %	0 %
Fsp5	9	Generator	0.03	1	0 %	10 %	0 %	0 %
Fsp6	10	Generator	0.04	1	0 %	10 %	0 %	0 %
Fsp7	11	Generator	0.01	1	0 %	10 %	0 %	0 %
Fsp8	7	Generator	1.5	1	0 %	10 %	0 %	0 %
Fsp9	1	Load	15.3	0.98	10 %	10 %	10 %	10 %
Fsp10	3	Load	0.285	0.97	10 %	10 %	10 %	10 %
Fsp11	4	Load	0.445	0.97	10 %	10 %	10 %	10 %
Fsp12	5	Load	0.75	0.97	10 %	10 %	10 %	10 %
Fsp13	6	Load	0.565	0.97	10 %	10 %	10 %	10 %
Fsp14	8	Load	0.605	0.97	10 %	10 %	10 %	10 %
Fsp15	10	Load	0.49	0.97	10 %	10 %	10 %	10 %
Fsp16	11	Load	0.34	0.97	10 %	10 %	10 %	10 %
Fsp17	12	Load	15.3	0.98	10 %	10 %	10 %	10 %
Fsp18	14	Load	0.215	0.97	10 %	10 %	10 %	10 %
Fsp19	1	Load	5.1	0.95	10 %	10 %	10 %	10 %
Fsp20	3	Load	0.265	0.85	10 %	10 %	10 %	10 %
Fsp21	7	Load	0.09	0.85	10 %	10 %	10 %	10 %
Fsp22	9	Load	0.675	0.85	10 %	10 %	10 %	10 %
Fsp23	10	Load	0.08	0.85	10 %	10 %	10 %	10 %
Fsp24	12	Load	5.28	0.95	10 %	10 %	10 %	10 %
Fsp25	13	Load	0.04	0.85	10 %	10 %	10 %	10 %
Fsp26	14	Load	0.39	0.85	10 %	10 %	10 %	10 %

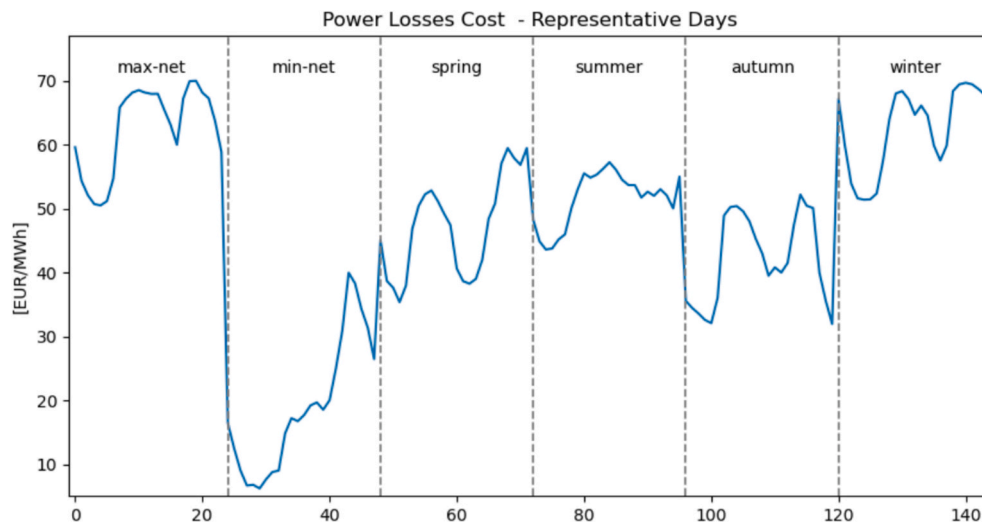

Fig. 5. Power losses cost by representative day (wholesale electricity market prices in Spain 2019).

the Spanish electrical system serves as a benchmark [44], see Fig. 5. FSPs submit upward bids at 10 % above this reference price and downward bids at 10 % below it. Although the development of FSPs' bidding strategies is beyond the scope of this paper, it is assumed that these strategies are influenced by wholesale market prices, which impact their opportunity costs.

- *Cost and other parameters*

Concerning power loss cost, we consider the wholesale day-ahead market prices from the Spanish electrical system for 2019 [44]. For each representative day, the corresponding hourly market prices were identified and incorporated into the model as power loss cost, see Fig. 5. Furthermore, a cost of 7880 EUR/MWh is considered to penalize instances of load shedding. This cost is equivalent to the domestic value of lost load (VOLL) in Spain as reported in [45]. To calculate the switching cost (5.2 EUR/switching operation), we refer to the information provided by i-DE, a Spanish DSO, as part of the Flexener project [36]. This calculation involves dividing the average replacement cost of a MV switch by the expected maximum number of switching operations over its 40-year lifespan. Regarding the generation curtailment cost, we adopt a price-regulatory approach [46], setting a compensation price for DG at 10 % below the market price shown in Fig. 5. Costs and other relevant parameters, such as bus voltage limits and power factor correction, are summarized in Table 6.

3.2. Case Study: Results

Considering the case study and inputs outlined in the previous subsection, the INV-DNR-FSP model described in Step 4 of Section 2 was implemented in Python using the matrix-based modelling approach of GurobiPy. The optimization was carried out using Gurobi Optimizer (version 12.0), which natively supports MIQCP models without

Table 6
Summary of additional parameters.

Input data	Description
Power loss cost [EUR/MWh]	According to [44]
EENS cost [EUR/MWh]	$C^{EENS} = 7880$
Switching cost [EUR/switching operation]	$C^{sw} = 5.2$
Generation curtailment cost [EUR/MWh]	Compensation price: 10 % below market price
Power factor correction	$p^{FC} = 0.95$
Bus voltage limits [p.u.]	$v^{min} = 0.93, v^{max} = 1.07$

requiring linearization [47]. The model was executed on a Windows server PC running at 2.10 GHz with 128 GB of RAM. The analysis begins by examining the impact of varying levels of load growth on the optimal solution. Based on these results, we analyze the trade-offs among investment strategies, DNR and Third-party flexibility.

- *Load Growth Analysis*

As demand patterns evolve over time, it becomes essential for DSOs to anticipate and plan for future load increases to ensure reliable and efficient network operation. Therefore, we test the INV-DNR-FSP model under different scenarios to assess its effectiveness in addressing different levels of load growth, as illustrated in Figs. 6-8. Eight scenarios are examined, starting with a base scenario that involves an optimal power flow analysis to establish a benchmark, and the subsequent scenarios explore different combinations of investment in new assets, the procurement of flexibility from FSPs, and/or the use of network reconfiguration to address the grid congestions identified in the case study.

Fig. 6 compares the annual total system cost (model's objective function) for each scenario with load profiles scaled by a factor of 1.1, as no congestion problems were identified with the original load and generation profiles (see Table 7). Notably, network reconfiguration alone effectively mitigates congestion problems that arise when load is scaled to 1.1, thereby eliminating the energy non-supplied and representing the optimal solution in economic terms. However, scaling the demand by a factor of 1.2 (see Fig. 7) indicates that the most cost-effective solution to address congestions combines DNR and the procurement of flexibility from FSPs. Nevertheless, when demand is scaled further to 1.3 (Fig. 8) the model prioritizes solutions that entail new investments, as the base scenario and solutions relying solely on DNR or FSP perform less effectively due to the extremely high EENS cost. The best solution (71705 EUR) combines the investment in a new transformer TOI, network reconfiguration, and the procurement of flexibility from FSPs. This solution mitigates all congestion problems present in the base scenario, reducing power losses and eliminating the EENS.

It is important to note that, in the scenarios involving FSPs, the flexibility procured corresponds to upward active power, along with the associated reactive power, as enforced by constraint (37) (see Section 2.4). This outcome reflects the nature of the congestion issues observed in the case study, which are primarily related to grid element overloads and bus undervoltages due to load growth. If, instead, congestions were caused by excess generation, downward flexibility would be required. Therefore, the type of flexibility procured is inherently determined by the nature and direction of the congestion.

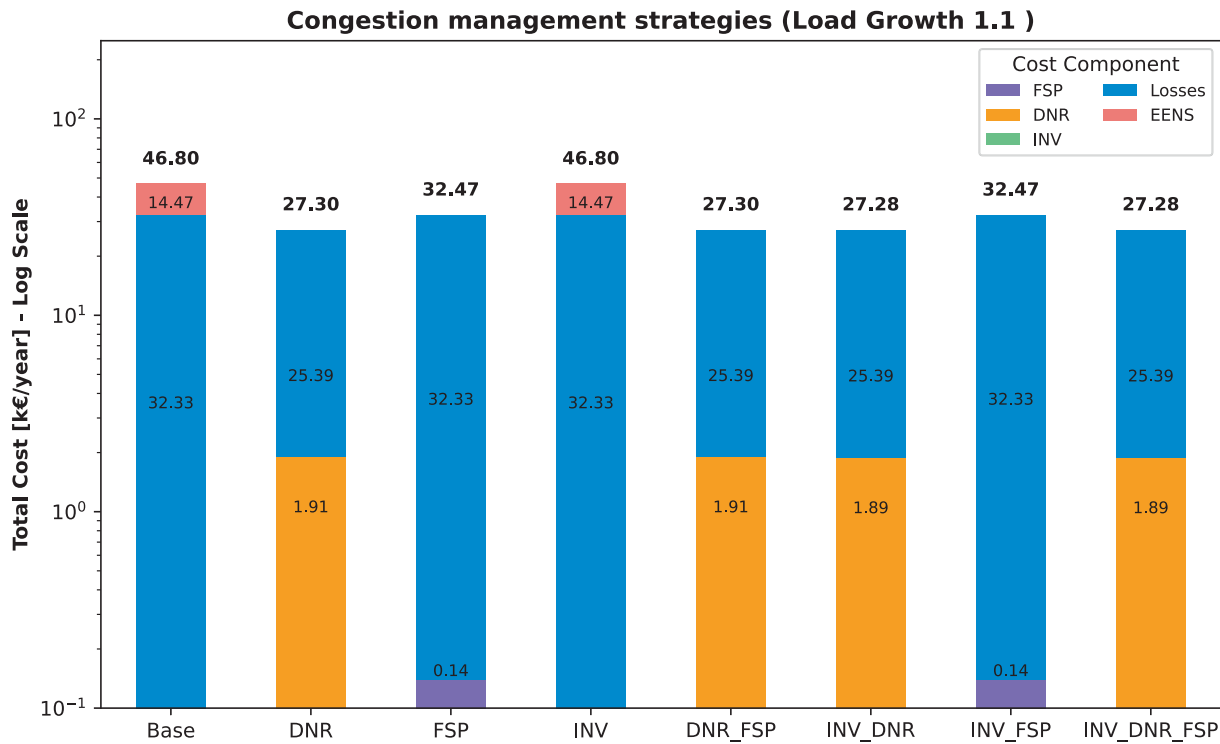

Fig. 6. Total distribution system costs (k€/year) for a load growth of 1.1. The Base scenario shows costs without congestion management (optimal power flow), while other scenarios apply INV, DNR, and/or FSPs to mitigate grid congestions. A logarithmic scale is used for the y-axis.

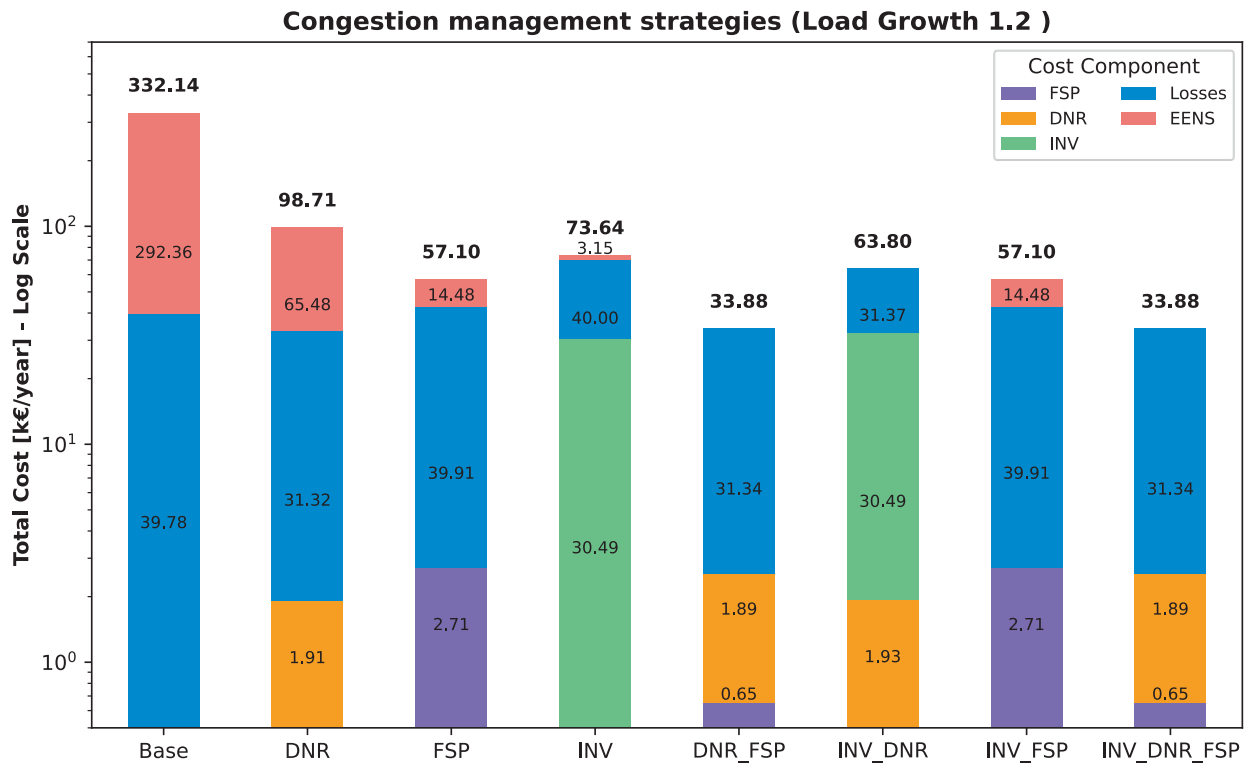

Fig. 7. Total distribution system costs (k€/year) for a load growth of 1.2. The Base scenario shows costs without congestion management (optimal power flow), while other scenarios apply INV, DNR, and/or FSPs to mitigate grid congestions. A logarithmic scale is used for the y-axis.

Based on these findings, it can be highlighted that at lower levels of demand growth, solutions involving DSO's own flexibility resources (DNR) can be sufficient and cost-effective to mitigate grid congestions. However, as demand grows more significantly, integrated solutions that

combine DNR, infrastructure investment and/or the procurement of flexibility from third parties become necessary. The trade-offs among this solution's INV, DNR, and FSP are further analyzed in the following section for a clearer understanding.

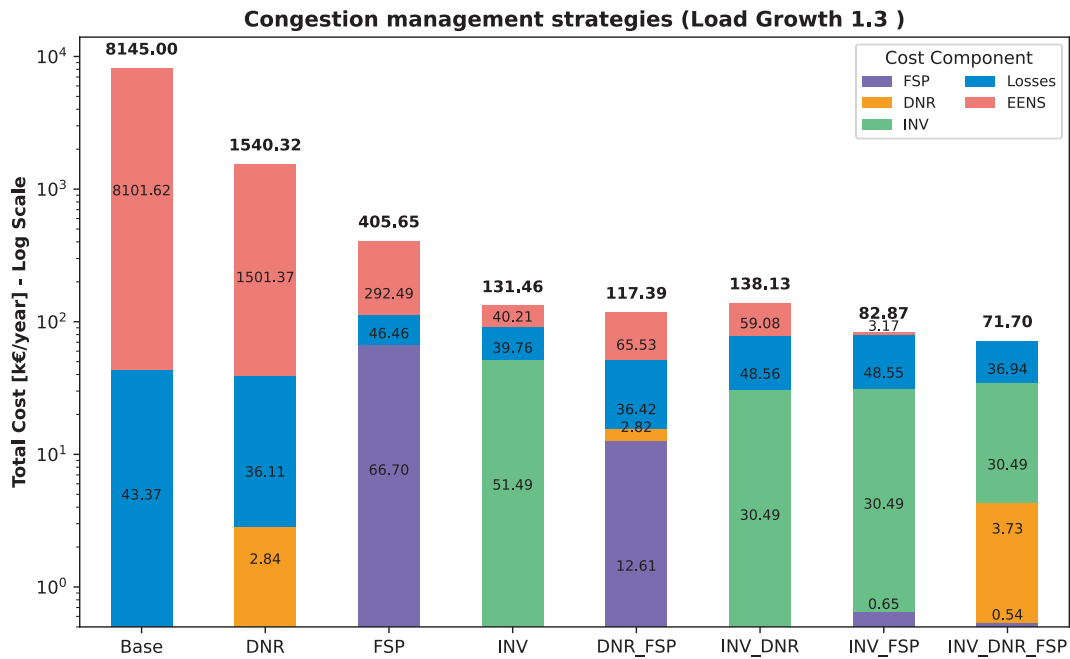

Fig. 8. Total distribution system costs (k€/year) for a load growth of 1.3. The Base scenario shows costs without congestion management (optimal power flow), while other scenarios apply INV, DNR, and/or FSPs to mitigate grid congestions. A logarithmic scale is used for the y-axis.

Table 7

Summary of congested elements under different levels of load growth (Base Scenario), representative days when congestion occurs are shown in parentheses.

Load Growth Level	1.0	1.1	1.2	1.3
Overloaded Transformers	None	T0 (max-net)	T0 (max-net)	T0 (max-net, summer, winter)
Overloaded Lines	None	L0, L1 (max-net)	L0, L1 (max-net)	L0, L1 (max-net)
Undervoltage Buses	None	B6-B11 (max-net)	B4-B11 (max-net)	B3-B11 (max-net)
Overvoltage Buses	None	None	None	None

• Trade-offs between INV-DNR-FSP

While the previous analysis examined the evolution of total system cost under relevant scenarios, this section provides a detailed assessment of the occurrence of EENS, the network topology changes, and when investment and third-party flexibility are required across the

representative days, based on the results presented in Fig. 8 (load growth 1.3). As reported in Table 8, the base case, which does not implement any congestion management strategy, leads to EENS during the max-net demand, summer, and winter days. Although the DNR-only scenario mitigates EENS by reconfiguring the network on certain days, it fails to fully eliminate it under peak conditions (max-net and summer). Similarly, the FSP-only and DNR_FSP scenarios successfully eliminate EENS on all days except the most critical day (max-net). Finally, the INV_DNR_FSP strategy, which incorporates targeted investment (in transformer TOI), reconfiguration, and third-party flexibility, is the only approach that eliminates EENS across all representative days while yielding the lowest total system cost.

Given that the most significant stress on this network occurs during the maximum net demand day, it is essential to analyze the interplay between network reconfiguration and third-party flexibility during this period. This dynamic is further illustrated in Fig. 9, which shows how the grid topology is adjusted during the most critical hour (t = 20:00) of this day. In the DNR scenario, the topology is modified, redistributing

Table 8

Trade-offs between INV-DNR-FSP under a load growth of 1.3.

Scenario	Representative Day	INV	FSP	DNR	DNR: Open switches				EENS
					1-4 h	5-13 h	14-17 h	18-24 h	
Base (8'144.997 EUR)	min-net, spring, autumn	No	No	No	L12, L13, L14 (normal operation topology)				No
	max-net, summer, winter								Yes
DNR (1'540.320 EUR)	spring, min-net				L12, L13, L14				No
	autumn, winter			Yes	<u>L9</u> , L12, L13				
	summer								Yes
	max-net				<u>L9</u> , L12, L13		<u>L8</u> , <u>L9</u> , L12		
FSP (405.650 EUR)	min-net, spring, autumn, winter, summer		Yes	No	L12, L13, L14				No
DNR_FSP (117.389 EUR)	max-net								Yes
	spring		No	No	L12, L13, L14				No
	min-net			Yes	L12, L13, L14				
	autumn, winter				<u>L9</u> , L12, L13				
INV_DNR_FSP (71.705 EUR)	summer		Yes						Yes
	max-net								No
	spring, min-net	Yes	No	No	L12, L13, L14				
	autumn, winter	(TOI)		Yes	<u>L9</u> , L12, L13				
INV_DNR_FSP	summer				<u>L8</u> , <u>L9</u> , L12				
	max-net		Yes		L12, L13, L14				<u>L8</u> , L12, L14

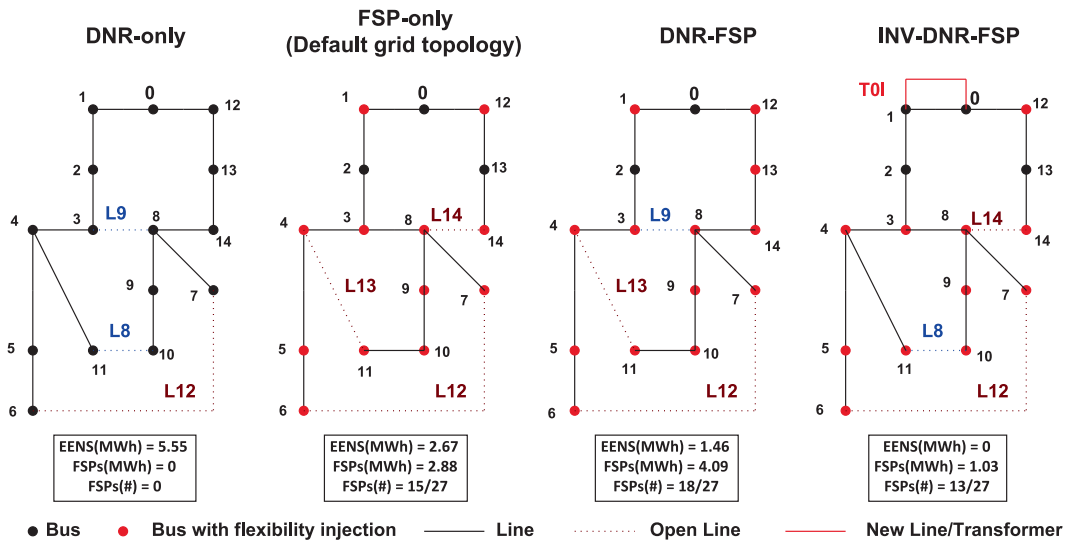

Fig. 9. Grid topology changes during the most critical hour ($t = 20:00$) on the maximum net demand day across different scenarios. The default topology in the Base Case is defined by open switches L12, L13, and L14 (Load growth factor: 1.3).

power flows, but EENS remains. In the FSP scenario, the default topology is preserved, with congestion addressed through extensive activation of FSPs, particularly those connected downstream of transformer T0. However, the available flexibility is insufficient to resolve the issue entirely. In contrast, the DNR_FSP scenario demonstrates how reconfiguration expands the geographic eligibility of FSPs, enabling more flexibility to be procured. Despite this enhanced participation, some EENS persists. The INV_DNR_FSP scenario achieves the best outcome by alleviating network stress through investment in transformer TOI. This reduces the need for frequent switching operations and flexibility activations while restoring the load distribution closer to the original configuration.

Fig. 10 complements this analysis by presenting the hourly loading of key transformers and lines for the most critical day. In the DNR and FSP cases, elements such as T0 and T1 operate near their loading limits, while the INV_DNR_FSP strategy achieves the most balanced loading, ensuring all components remain within safe operational thresholds throughout the maximum net demand day.

These results show that relying on reconfiguration or third-party flexibility procurement alone does not fully resolve peak congestion. Only the combined use of investment, reconfiguration, and FSP succeeds in eliminating EENS in this case study. Moreover, the observed interaction between network topology and third-party flexibility demonstrates that reconfiguration can enable broader participation of FSPs.

3.3. Case Study: Sensitivity analysis

Flexibility Service Providers Sensitivity Analysis

A new sensitivity analysis is conducted by scaling the FSPs' flexibility capacity and bidding cost. First, we consider the best scenario from Fig. 8 (INV_DNR_FSP) as a reference; here, flexibility bids (upwards and downwards) are as quantified as 10 % of their base profile (available flexibility). This percentage is then scaled up to 16 % for all FSPs, with the results illustrated in Fig. 11. From this figure, it is observed that increasing the available flexibility to up to 13 % does not alter the optimal solution of the reference scenario, which combines INV, DNR, and FSP. However, the total cost is reduced when the available flexibility is increased to 13 % and 14 %. Economically, procuring this amount of flexibility and accepting some levels of EENS becomes more advantageous than investing in the TOI transformer. Nevertheless, at 15 % available flexibility the EENS is completely eliminated, and the best solution involves using DNR and flexibility procurement without requiring new investments. These findings demonstrate that increasing the network's available flexibility – whether through the utilization of the DSO's own flexibility resources (DNR) and by having more FSPs (in terms of quantity and number and optimally localized) can mitigate the need for costly infrastructure investments, even under substantial load growth conditions.

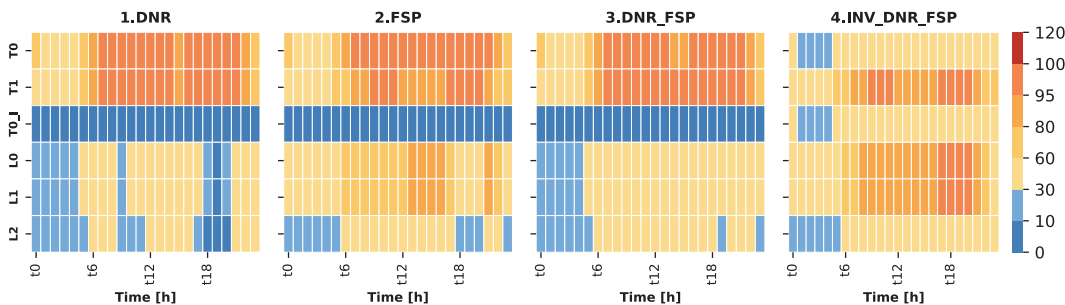

Fig. 10. Hourly loading of key lines and transformers on the maximum net demand day and under different congestion management strategies (Load growth factor: 1.3).

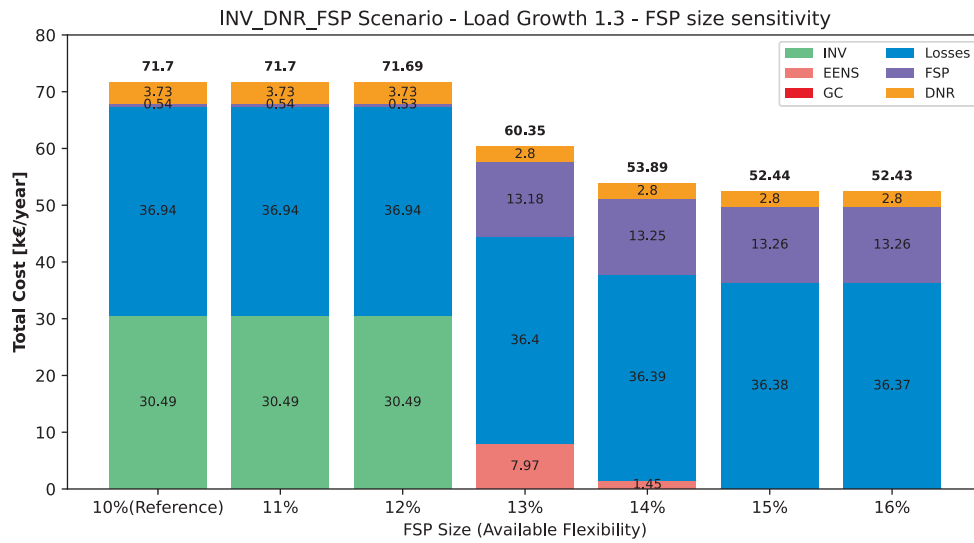

Fig. 11. Performance of the INV-DNR-FSP model for a load growth of 1.3 and increasing the FSPs' available flexibility.

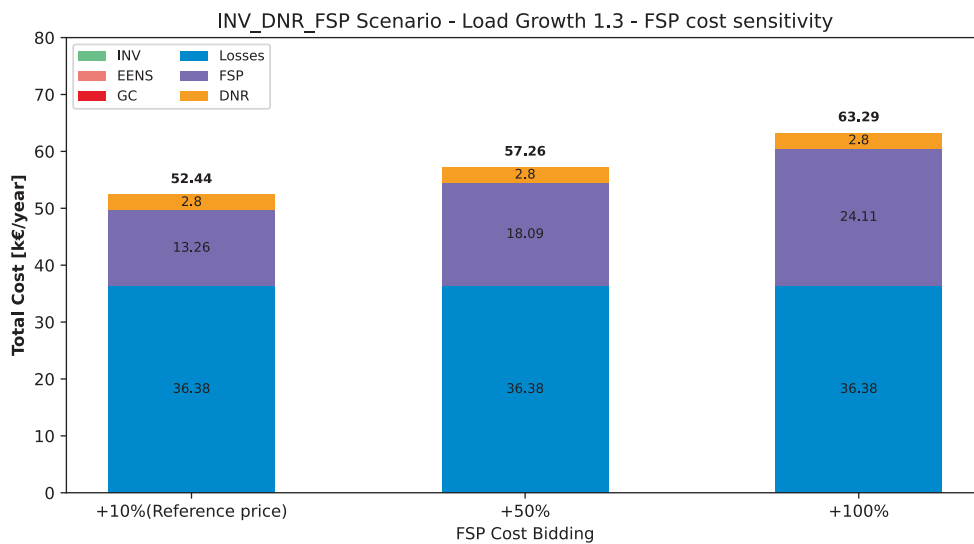

Fig. 12. Performance of the INV-DNR-FSP model under a load growth of 1.3 and 15% of available third-party flexibility, for different levels of FSPs' bidding cost.

Considering the above results, we further analyze how a higher flexibility bid pricing impacts the total yearly cost under the INV-DNR-FSP scenario with a load growth of 1.3 and 15 % available third-party flexibility. In the reference case, FSPs offer upward bids at 10 % above the wholesale market price. This percentage has increased to 50 % and 100 %. For this case study, as shown in Fig. 12, despite a significant increase in FSPs' bid pricing, there is no need for investment in new lines or transformers.

Table 9

Original and new weights of representative days.

Representative day	Date	Original Weights NRMSE: 4.25 %	New Weights NRMSE: 4.32 %
Maximum net demand	2019-01-08	4	1
Minimum net demand	2019-11-03	2	1
Spring day	2019-04-17	92	93
Summer day	2019-07-16	90	90
Autumn day	2019-10-14	88	88
Winter day	2019-01-12	89	92

• Impact of Weighting Representative Days

In this new sensitivity analysis, the weights assigned to the days with maximum and minimum net demand are varied to observe how the proposed model solutions vary. Therefore, the new weights for the seasonal days were derived from the k-Medoids algorithm, while the days with maximum and minimum net demand were each assigned a weight of 1. A comparison of the new weights and original ones calculated in Section 3.1 is shown in Table 9.

Fig. 13 illustrates the difference between the LDCs derived using the new and the original weighting approaches. The results clearly indicate that the proposed framework outlined in Section 2 produces representative day LDCs that more closely align with the original LDCs for both peak and base load conditions. Furthermore, Fig. 14 presents the change in the total system and EENS costs for a load growth of 1.3 when applying the new weights. Compared to the original weights (Fig. 8), the new weighting results in lower total cost across all scenarios. The most cost-effective solution under the new weights combines DNR and FSPs, although some value of EENS persists. By contrast, the optimal solution derived from the original weights combines INV, DNR, and FSP, resulting in a higher total cost but a complete elimination of EENS.

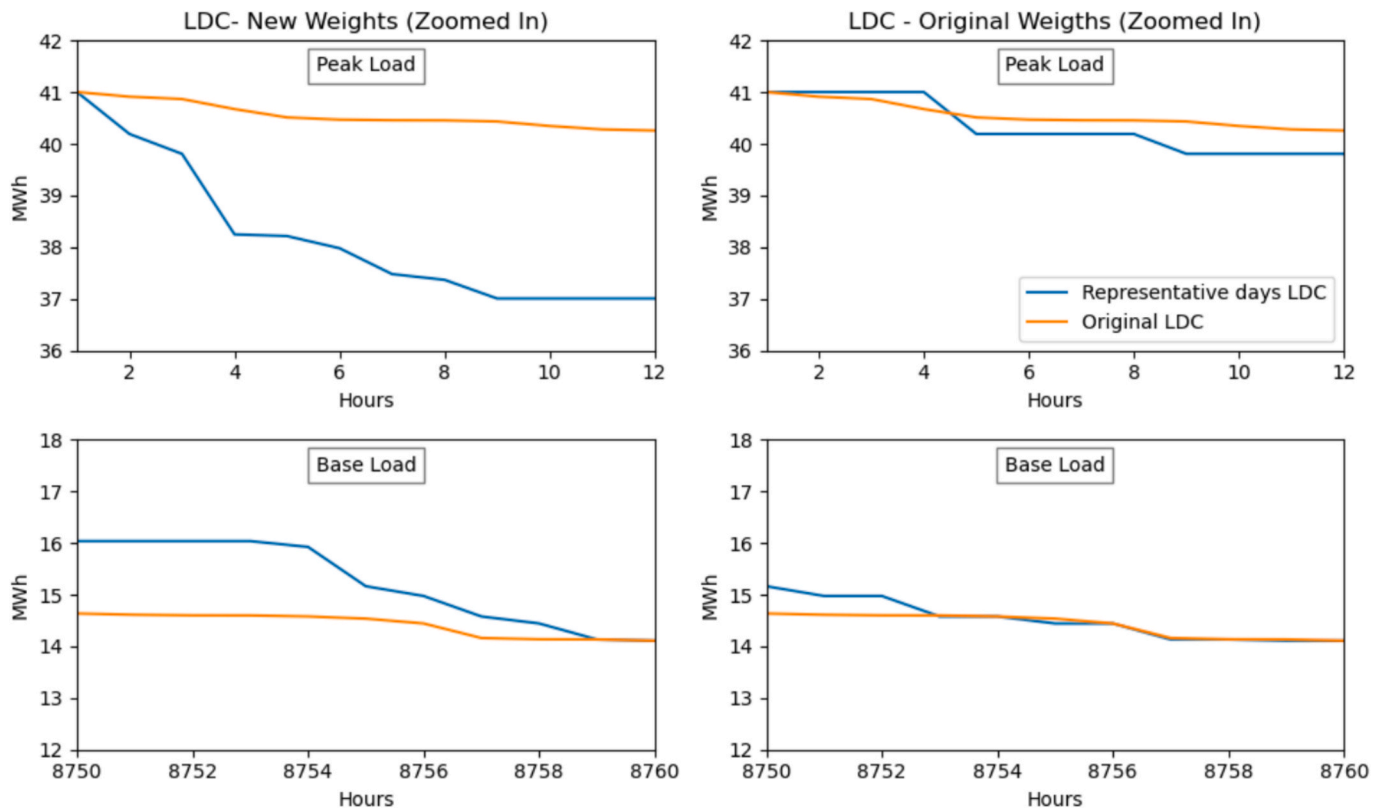

Fig. 13. Difference between load duration curves (New vs original weights of representative days).

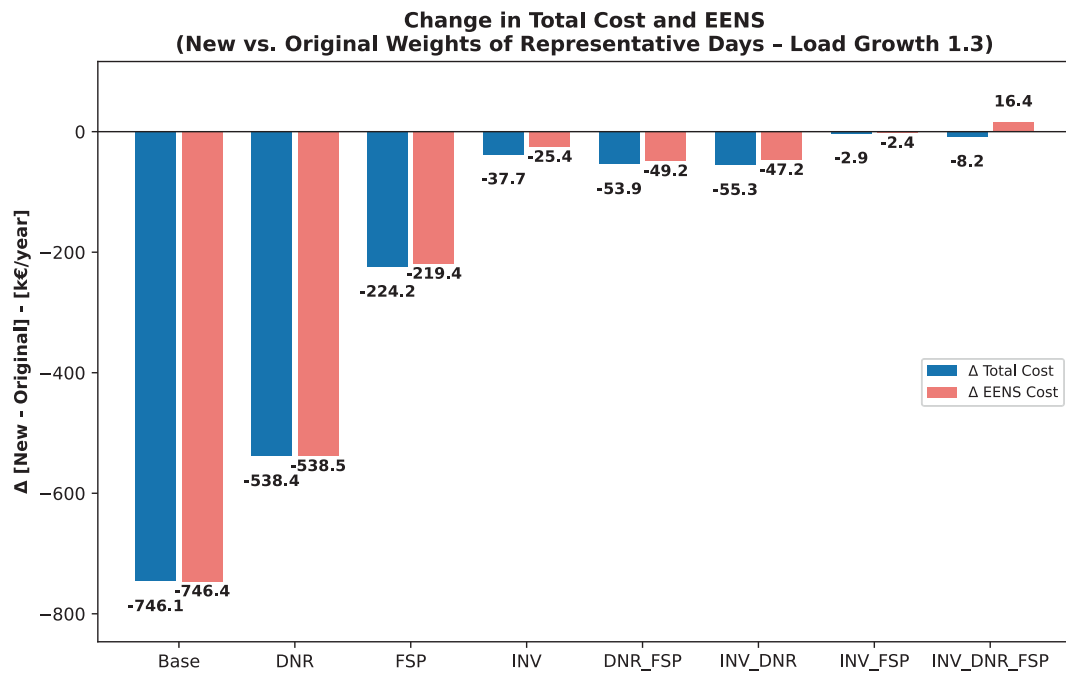

Fig. 14. Change in the Total system and EENS costs between the new and original representative day weights for a load growth of 1.3. Negative values indicate a reduction under the new weights, though lower EENS may reflect a mismatch with the original load duration curve.

However, the apparent cost reduction under the new weights is primarily driven by the significant decrease in EENS, which is likely underestimated. This is because the LDC curve using the new weights does not adequately capture peak demand conditions.

Therefore, this analysis underscores the need for DSOs to carefully consider the weighting of representative days to align with their

operational priorities and risk tolerance. Given that DSOs may be penalized or credited according to the actual quality of supply, balancing these weights through the methodology proposed in Section 3 is recommended. This approach supports the development of cost-effective, reliable, and efficient network operation and planning strategies.

4. Discussion and future research

Building on the results presented in Section 3, this section discusses the broader implications of integrating flexibility resources into distribution planning and outlines several directions for future research. The discussion concentrates on five critical aspects:

- Operational reliability and complexity:** The results indicate that combining investment in network infrastructure, DNR, and the procurement of third-party flexibility yields the most cost-effective outcomes across sensitivity scenarios. However, as shown in this case study, at lower levels of demand growth and when sufficient flexibility from FSP is available, a combination of DNR and/or FSP can mitigate the need for costly infrastructure investments. However, dependence solely on network reconfiguration and/or third-party flexibility introduces potential drawbacks, notably in terms of operational reliability and complexity. Frequent network topology changes can precipitate transient faults, system instability and necessitate more frequent maintenance of switches, underscoring the importance of assessing switching costs rigorously. Additionally, the efficacy of third-party flexibility is critically influenced by the availability of FSPs within the system, as evidenced in Fig. 11. Therefore, to ensure both cost-effectiveness and reliability in network operation, DSOs must meticulously consider these factors when identifying the best strategy between the alternatives presented in this paper. Future research could explore integrating reliability assessments of resultant network topologies and evaluating the feasibility of third-party flexibility solutions to enhance the robustness and applicability of these findings.
- Hidden costs:** In this paper, it was demonstrated that the DNR and the procurement of flexibility from third parties have the potential to reduce OPEX, and thus CAPEX in grid reinforcements are anticipated to decrease under this interaction. However, deploying DNR and/or FSP solutions necessitates several advancements in infrastructure. Specifically, these strategies require significant digitalization upgrades, including enhanced grid automation and advanced control systems. For instance, establishing and maintaining a LFM platform further contributes to CAPEX, as these platforms involve substantial initial setup costs and ongoing operational expenses. Therefore, future INV-DNR-FSP models should account for these additional investment and operational costs to provide a more comprehensive evaluation of the economic and technical feasibility of these solutions.
- Alternative third-party flexibility mechanisms:** As highlighted earlier, the proposed model is primarily designed to integrate third-party flexibility using explicit mechanisms, such as local flexibility markets or bilateral contracts. In future work, the model could be extended to include additional mechanisms, both explicit, such as flexible connection agreements, and implicit, such as dynamic network tariffs [14,48]. Although integrating these mechanisms alongside investment and reconfiguration would increase the model's complexity, doing so would offer DSOs a more comprehensive tool for congestion management decision-making.
- DSO roles and responsibilities:** The proposed model assumes that the DSO is responsible for managing the procurement of flexibility, either directly or through dedicated platforms. For this reason, a comprehensive network representation is included in the model formulation. However, a third-party entity could also take on this role. For example, the upcoming European Network Code for Demand Response specifies that local flexibility markets may be operated by independent third parties [15]. Future research should therefore examine the implications of modelling the coordination between investment, network reconfiguration, and flexibility procurement when this task is handled by a third party. In such cases, it is important to clearly separate the market-clearing process from both network reconfiguration and planning, as these remain the

responsibility of the DSO. Additionally, since network data is often treated as confidential by DSOs, third-party market operators may not have access to detailed grid information. This can result in market-clearing processes that do not fully reflect network conditions, reducing the effectiveness of congestion management.

- Modeling challenges and uncertainty:** Traditional network planning studies typically employ deterministic methods focusing on worst-case scenarios. However, with the integration of flexibility services, there is a need to consider a broader range of scenarios, necessitating the adoption of probabilistic or stochastic approaches. Therefore, testing the proposed INV-DNR-FSP model under profiles that account for inherent uncertainty is crucial. This methodological shift is highly recommended for future research, as it enhances the model's adaptability and responsiveness to meet the dynamic requirements of the network and improves its effectiveness in addressing real-world challenges. Moreover, incorporating switching costs into the proposed model introduces additional complexities, including the need for extra binary variables and intertemporal constraints. These factors significantly elevate the computational burden of the model. To mitigate this challenge and facilitate its practical implementation in large-scale networks, future research should explore methodologies for strategically selecting switchable lines.
- Market gaming:** Market-based solutions are the preferred and by-default option for procuring local services in Europe [15]. However, because of its local character, FSPs may influence prices with gaming strategies. Therefore, a potential application of the proposed INV-DNR-FSP model is to investigate how changes in the network topology can mitigate gaming opportunities by grid users who own a significant market share in strategic network locations. For instance, DNR can adjust the grid topology to redistribute power flows and change congestion areas, as shown in Fig. 9. This can make it more challenging for grid users to create artificial congestion where they can profit from its resolution. Future work can focus on analyzing specific case studies where market gaming may be exercised and assessing the effectiveness of the proposed model in preventing and addressing these issues.
- Summary of limitations and outlook:** Despite the advantages of the proposed model, several limitations warrant acknowledgment. First, the model does not include a reliability assessment of the resulting network topologies, which may lead to suboptimal or infeasible solutions from an operational standpoint. Second, the modelling of third-party flexibility procurement is simplified. The current formulation does not account for some aspects of market-based mechanisms, such as bidding behavior, settlement rules, and strategic actions by FSPs. Third, uncertainty is addressed only partially through representative days, which may not fully capture system conditions' variability and temporal correlation. Additionally, it would be valuable to apply the proposed model to a range of distribution systems to assess how the choice and effectiveness of congestion management strategies depend on system-specific characteristics, such as voltage level, the availability of third-party flexibility, the degree of network automation, and the penetration of renewable energy sources. These limitations suggest important directions for future research to enhance the model's realism, scalability, and alignment with practical and regulatory requirements.

5. Conclusions

This paper has presented a unified optimization model that assesses the trade-offs among three coordinated strategies for managing congestion in distribution networks: grid investment, network reconfiguration, and the procurement of third-party flexibility. The proposed approach enables an efficient allocation of capital and operational expenditures while explicitly accounting for the influence of network topology on the geographic eligibility and participation of flexibility

providers. This aspect is often overlooked in existing distribution planning models.

The results demonstrate that reconfiguration alone may be a sufficient and cost-effective strategy under moderate demand growth, while greater third-party flexibility availability can substantially defer or replace costly grid reinforcements. At higher levels of congestion, combining all three strategies yields the most economically and operationally robust solution.

This framework supports DSOs in navigating the increasing complexity of distribution system planning, aligning investment decisions with evolving regulatory mandates prioritizing the market-based procurement of local services. It also provides valuable insights for regulators and market operators seeking to strengthen coordination between long-term planning and operational flexibility.

Looking ahead, future research should focus on incorporating reliability assessments of reconfigured topologies, modelling more detailed flexibility market dynamics, and accounting for system uncertainty using stochastic optimization. Extending the framework to consider other flexibility mechanisms, third-party-operated LfMs, and infrastructure upgrade costs associated with DNR and LfM deployment will further improve its applicability and alignment with emerging regulations and new market designs.

CRedit authorship contribution statement

Orlando Valarezo: Writing – review & editing, Writing – original draft, Visualization, Validation, Methodology, Investigation, Data curation, Conceptualization. **Tomás Gómez:** Writing – review & editing, Validation, Supervision, Methodology, Investigation, Formal analysis, Conceptualization. **José Pablo Chaves-Ávila:** Writing – review & editing, Validation, Supervision, Methodology, Investigation, Formal analysis, Conceptualization. **Cristian Alcarraz:** Writing – review & editing, Validation, Supervision, Methodology, Formal analysis. **Pierluigi Mancarella:** Writing – review & editing, Validation, Supervision, Methodology, Investigation, Formal analysis, Conceptualization.

Declaration of competing interest

The authors declare that they have no known competing financial interests or personal relationships that could have appeared to influence the work reported in this paper.

Data availability

The input data supporting this study are available on Zenodo at <https://doi.org/10.5281/zenodo.15301968>

References

- Ruiz MA, Gómez T, Chaves JP, Cossent R. Regulatory challenges for energy infrastructure—do electricity distribution remuneration schemes in Europe promote the use of flexibility from connected users? *Curr Sustain Energy Reports* 2023;10(3):112–7. <https://doi.org/10.1007/s40518-023-00214-5>.
- CEDEC, EDSO, Eurelectric, and GEODE. “Flexibility in the energy transition: A toolbox for electricity DSOs,” 2018.
- M. Martínez, C. Mateo, T. Gómez, B. Alonso, and P. Frías, “A hybrid particle swarm optimization approach for explicit flexibility procurement in distribution network planning,” *Int. J. Electr. Power Energy Syst.*, vol. 161, no. May, 2024, doi: 10.1016/j.ijepes.2024.110215.
- O. Valarezo, J. P. Chaves-Ávila, and T. Gómez, “Exploring the Interaction Between Electricity Distribution Network Reconfiguration and Local Flexibility Markets,” *Curr. Sustain. Energy Reports*, no. 0123456789, 2023, doi: 10.1007/s40518-023-00221-6.
- Dorostkar-Ghamsari MR, Fotuhi-Firuzabad M, Lehtonen M, Safdarian A. Value of distribution network reconfiguration in presence of renewable energy resources. *IEEE Trans Power Syst* 2016;31(3):1879–88. <https://doi.org/10.1109/TPWRS.2015.2457954>.
- Rao RS, Ravindra K, Satish K, Narasimham SVL. Power loss minimization in distribution system using network reconfiguration in the presence of distributed generation. *IEEE Trans Power Syst* 2013;28(1):317–25. <https://doi.org/10.1109/TPWRS.2012.2197227>.
- Liu Y, Li J, Wu L. Coordinated optimal network reconfiguration and voltage regulator/DER control for unbalanced distribution systems. *IEEE Trans Smart Grid* 2019;10(3):2912–22. <https://doi.org/10.1109/TSG.2018.2815010>.
- Bai L, Wang J, Wang C, Chen C, Li F. Distribution locational marginal pricing (DLMP) for congestion management and voltage support. *IEEE Trans Power Syst* 2018;33(4):4061–73. <https://doi.org/10.1109/TPWRS.2017.2767632>.
- Shen F, Huang S, Wu Q, Repo S, Xu Y, Ostergaard J. Comprehensive congestion management for distribution networks based on dynamic tariff, reconfiguration and re-profiling product. *IEEE Trans Smart Grid* 2019;10(5):4795–805. <https://doi.org/10.1109/TSG.2018.2868755>.
- Agrawal P, Kanwar N, Gupta N, Niazi KR, Swarnkar A. “Resiliency in active distribution systems via network reconfiguration,” *Sustain. Energy, Grids Networks* 2021;26:100434. <https://doi.org/10.1016/j.segan.2021.100434>.
- Herding L, Carvalho L, Cossent R, Rivier M. A security-aware dynamic hosting capacity approach to enhance the integration of renewable generation in distribution networks. *Int J Electr Power Energy Syst* 2024;vol. 161, no. February: 110210. <https://doi.org/10.1016/j.ijepes.2024.110210>.
- González A, Echavarren FM, Rouco L, Gómez T, Cabetas J. Reconfiguration of large-scale distribution networks for planning studies. *Int J Electr Power Energy Syst* 2012;37(1):86–94. <https://doi.org/10.1016/j.ijepes.2011.12.009>.
- Marquez JA, et al. Optimal planning and operation of distribution systems using network reconfiguration and flexibility services. *Energy Rep* 2023;9:3910–9. <https://doi.org/10.1016/j.egyr.2023.02.082>.
- E. Ormeño, M. José, P. Chaves, and Á. Matteo, “Unlocking Flexibility from Third-Party Resources : Decoding the Interaction between Mechanisms for Acquiring Distribution System Operator Services,” *Curr. Sustain. Energy Reports*, no. 0123456789, 2024, doi: 10.1007/s40518-024-00236-7.
- ACER. “Proposal for a new EU-wide Network Code on Demand Response,” 2025. [Online]. Available: <https://www.acer.europa.eu/news/new-network-code-demand-response-will-further-advance-energy-transition>.
- O. Valarezo et al., “EUniversal D10.4: Scalability and Replicability analysis of the EUniversal solutions,” 2023.
- L. Lind, O. Valarezo, M. Troncia, and J. P. Chaves-Ávila, “CoordiNet D6.4 – Scalability and replicability analysis of the market platform and standardised products,” 2020.
- “OneNet Project Website.” [Online]. Available: <https://onenet-project.eu/>. [Accessed: 25-Apr-2025].
- Olivella-Rosell P, et al. Local flexibility market design for aggregators providing multiple flexibility services at distribution network level. *Energies* 2018;11(4): 1–19. <https://doi.org/10.3390/en11040822>.
- Correa-Florez CA, Michiorri A, Kariniotakis G. Optimal participation of residential aggregators in energy and local flexibility markets. *IEEE Trans Smart Grid* 2020;11(2):1644–56. <https://doi.org/10.1109/TSG.2019.2941687>.
- Papazoglou GK, Forouli AA, Bakirtzis EA, Biskas PN, Bakirtzis AG. Day-ahead local flexibility market for active and reactive power with linearized network constraints. *Electr Pow Syst Res* 2022;vol. 212, no. July:108317. <https://doi.org/10.1016/j.epr.2022.108317>.
- Shen F, Wu Q, Jin X, Zhou B, Li C, Xu Y. ADMM-based market clearing and optimal flexibility bidding of distribution-level flexibility market for day-ahead congestion management of distribution networks. *Int J Electr Power Energy Syst* 2020;123: 106266. <https://doi.org/10.1016/j.ijepes.2020.106266>.
- Antal C, et al. Blockchain based decentralized local energy flexibility market. *Energy Rep* 2021;7:5269–88. <https://doi.org/10.1016/j.egyr.2021.08.118>.
- C. Heinrich, C. Ziras, T. V. Jensen, H. W. Bindner, and J. Kazempour, “A local flexibility market mechanism with capacity limitation services,” *Energy Policy*, vol. 156, no. March, p. 112335, 2021, doi: 10.1016/j.enpol.2021.112335.
- Jahns C, Stein T, Höckner J, Weber C. Prevention of strategic behaviour in local flexibility markets using market monitoring – concept, application example and limitations. *Energy Policy* 2022;174(September):2023. <https://doi.org/10.1016/j.enpol.2023.113427>.
- Tabares A, Franco JF, Lavorato M, Rider MJ. Multistage long-term expansion planning of electrical distribution systems considering multiple alternatives. *IEEE Trans Power Syst* 2016;31(3):1900–14. <https://doi.org/10.1109/TPWRS.2015.2448942>.
- Santos SF, Fitiwi DZ, Cruz MRM, Cabrita CMP, Catalão JPS. Impacts of optimal energy storage deployment and network reconfiguration on renewable integration level in distribution systems. *Appl Energy* 2017;185:44–55. <https://doi.org/10.1016/j.apenergy.2016.10.053>.
- Klyapovskiy S, You S, Michiorri A, Kariniotakis G, Bindner HW. Incorporating flexibility options into distribution grid reinforcement planning: a techno-economic framework approach. *Appl Energy* 2019;vol. 254, no. August:113662. <https://doi.org/10.1016/j.apenergy.2019.113662>.
- Schachter JA, Mancarella P, Moriarty J, Shaw R. Flexible investment under uncertainty in smart distribution networks with demand side response: assessment framework and practical implementation. *Energy Policy* 2016;97:439–49. <https://doi.org/10.1016/j.enpol.2016.07.038>.
- Arasteh H, Sepasian MS, Vahidinasab V. An aggregated model for coordinated planning and reconfiguration of electric distribution networks. *Energy* 2016;94: 786–98. <https://doi.org/10.1016/j.energy.2015.11.053>.
- Martin-Utrilla FD, Chaves-Avila JP, Cossent R. Value of flexibility alternatives for real distribution networks in the con of the energy transition. *IEEE Access* 2023;11(October):114250–69. <https://doi.org/10.1109/ACCESS.2023.3322365>.
- S. Püschel-Løvengreen, S. Mhanna, P. Apablaza, P. Mancarella, J. Bukenberger, and M. Ortega-Vazquez, “Assessing flexibility, risk, and resilience in low-carbon power system planning under deep uncertainty,” 2023. [Online]. Available: <https://www.>

- csiro.au/-/media/EF/Files/GPST-Roadmap/Final-Reports/Topic-4-GPST-Stage-2.pdf. [Accessed: 04-Jul-2025].
- [33] Poncelet K, Hoschle H, Delarue E, Virag A, Drhaeseleer W. Selecting representative days for capturing the implications of integrating intermittent renewables in generation expansion planning problems. *IEEE Trans Power Syst* 2017;32(3): 1936–48. <https://doi.org/10.1109/TPWRS.2016.2596803>.
- [34] Thurner L, et al. Pandapower - an open-source python tool for convenient modeling, analysis, and optimization of electric power systems. *IEEE Trans Power Syst* 2018;33(6):6510–21. <https://doi.org/10.1109/TPWRS.2018.2829021>.
- [35] "k-Medoids clustering." [Online]. Available: <https://pypi.org/project/kmedoids/>. [Accessed: 06-May-2025].
- [36] O. Valarezo, J. P. Chaves-Ávila, and T. Gomez, "Multi-objective distribution network reconfiguration: application to a real large-scale distribution system," 2024. [Online]. Available: https://www.iit.comillas.edu/publicacion/workingpaper/es/529/Multi-objective_distribution_network_reconfiguration:_application_to_a_real_large-scale_distribution_system. [Accessed: 05-May-2025].
- [37] Potenciano S, Valarezo O. Decoding design characteristics of local flexibility markets for congestion management with a multi-layered taxonomy. *Energy: Appl*; 2023.
- [38] I. J. Pérez-Arriaga, *Regulation of the power sector*, vol. 61. 2013.
- [39] Farivar M, Chen L, Low S. Equilibrium and dynamics of local voltage control in distribution systems. In: in *52nd IEEE Conference on Decision and Control*; 2013. p. 4329–34. <https://doi.org/10.1109/CDC.2013.6760555>.
- [40] Lavorato M, Franco JF, Rider MJ, Romero R. Imposing radiality constraints in distribution system optimization problems. *IEEE Trans Power Syst* 2013;28(1): 568–9. <https://doi.org/10.1109/TPWRS.2012.2236475>.
- [41] K. Rudion, A. Orths, Z. A. Styczynski, and K. Strunz, "Design of benchmark of medium voltage distribution network for investigation of DG integration," *2006 IEEE Power Eng. Soc. Gen. Meet. PES*, p. 6 pp., 2006, doi: 10.1109/pes.2006.1709447.
- [42] RED Eléctrica España, "ESIOS - Red Eléctrica." [Online]. Available: <https://www.esios.ree.es/es/generacion-y-consumo?date=05-05-2025>. [Accessed: 05-May-2025].
- [43] E. y T. Ministerio de Industria, "Orden IET/2660/2015: BOE-A-2015-13488," 2015. [Online]. Available: <https://www.boe.es/eli/es/o/2015/12/11/iet2660>. [Accessed: 05-May-2025].
- [44] OMIE, "OMIE." [Online]. Available: <https://www.omie.es/>. [Accessed: 05-May-2025].
- [45] ACER/ CEPA, "Study on the estimation of the Value of Lost Load of electricity supply in Europe," no. July, pp. 1–116, 2018.
- [46] Huang Y, Söder L. An investigation on the impacts of distributed generation curtailment regulations on distribution network investment. *Electr Pow Syst Res* 2017;145:175–84. <https://doi.org/10.1016/j.epr.2016.12.020>.
- [47] Gurobi, "Gurobi Optimization." [Online]. Available: <https://www.gurobi.com/>. [Accessed: 05-May-2025].
- [48] Ormeño E, Troncia M, Chaves-Ávila J, Valarezo O, Galici M. Integrating third-party flexibility resources into distribution networks: a quantitative assessment on the interactions of network tariffs and local markets. *IET Conf Proc* 2024;2024(29): 631–6. <https://doi.org/10.1049/icp.2024.4731>.