

UNIVERSIDAD PONTIFICIA COMILLAS DE MADRID
ESCUELA TÉCNICA SUPERIOR DE INGENIERÍA (ICAI)
(Instituto de Investigación Tecnológica)

**METHODOLOGY FOR BENEFIT
ANALYSIS OF TRANSMISSION
EXPANSION PROJECTS**

Tesis para la obtención del grado de Doctor

Director: Dr. Luis Olmos Camacho

Co-Director: Dr. Jesús M. Latorre Canteli

Autor: Ing. Fernando Bañez Chicharro



Madrid 2017

A Andrea y mis padres

Resumen

Esta tesis propone una nueva metodología para evaluar los beneficios y los beneficiarios producidos por los proyectos de expansión de la red de transporte incluidos en un plan de expansión.

En primer lugar, esta tesis identifica y discute las características que son necesarias para una correcta evaluación de los beneficios producidos por los proyectos de un plan de expansión, así como de los beneficios que obtienen los usuarios de la red. Este análisis muestra que cualquier método empleado para la evaluación de los beneficios de los proyectos de un plan tiene que ser coherente con los principios técnicos y económicos que determinan la planificación óptima de la red. Bajo estos principios, los proyectos de un plan de expansión se seleccionan de acuerdo a los beneficios que producirán cuando se consideran junto a otros proyectos del plan. Las características identificadas se usan entonces como criterio de comparación para evaluar los métodos existentes que se usan para determinar los beneficios y los beneficiarios de los proyectos de expansión de un plan. Esta revisión muestra que ninguno de los métodos existentes es capaz de cumplir con las características requeridas.

El método propuesto en esta tesis se basa en teoría de juegos cooperativos, en concreto Aumann-Shapley. Los juegos formulados consideran que la función que se va a repartir son los beneficios obtenidos (por el sistema o por los usuarios de la red) y los jugadores del juego cooperativo son los proyectos de expansión. También se ha identificado que algunos de los beneficios obtenidos por los usuarios de la red (de los proyectos de expansión) evolucionan de forma continua, mientras que otros beneficios son discretos, ya que ocurren en puntos determinados en el proceso de implementación del plan. En consecuencia, se usan juegos de Aumann-Shapley separados para repartir los beneficios continuos y discretos. En el caso de los beneficios discretos, el algoritmo estándar de Aumann-Shapley para el reparto de los beneficios se modifica para afrontar que la función de beneficios de los usuarios de la red es discontinua respecto al tamaño de los proyectos.

Dos casos de estudio se usan para comparar el método propuesto con los existentes y demostrar su aplicabilidad para la toma de decisiones en la expansión de la red de transporte. Los resultados demuestran que el método propuesto no presenta los problemas detectados en los otros métodos y obtiene resultados más precisos y consistentes. Las ventajas de este método hacen que sea aplicable a los problemas relacionados con la regulación de la expansión de la red, como el reparto de los costes de nuevas inversiones o la identificación de los proyectos prioritarios.

Abstract

This thesis proposes a novel method to assess the benefits and beneficiaries produced by transmission expansion projects within an expansion plan.

First, the characteristics required for a method to accurately determine the benefits of the expansion projects comprising a plan, and those obtained from them by the individual users of the network, are identified and discussed. This discussion shows that any method applied should be coherent with the technical and economic principles that underlie an efficient planning of the network expansion, where expansion projects are selected to be part of the plan according to the benefit they produce when considered jointly with the rest of projects. Using these identified characteristics as a benchmark, the existing methods to analyze the benefits and beneficiaries of expansion projects within a plan, or group, are reviewed. This review shows that none of the existing methods features most of the characteristics desired.

The method developed in this thesis is based on cooperative game theory, and in particular the Aumann-Shapley concept. The games formulated consider that the function to be allocated are the benefits obtained (by the system or by the network users) and the players of the game are the expansion projects. The thesis also identified that some benefits obtained by network users from expansion projects evolve continuously with the deployment of the expansion plan, while others are discrete, since they occur at certain points of the deployment of this plan. A separate Aumann-Shapley game is solved to allocate continuous benefits, and each discrete one. In the second case, the standard Aumann-Shapley algorithm for the allocation of benefits is modified to cope with the fact that the function of each user's benefits is not continuous with the size of projects deployed.

Two case studies are used to compare the proposed method with existing ones and demonstrate its applicability to real-life decision making processes. The results show that the proposed method is able to overcome problems detected in other methods, providing more accurate and sound results. The good properties of the proposed method make it applicable to problems related to network expansion regulation, such as the cost allocation of new investments or the identification of high-priority expansion projects.

Agradecimientos

Contents

Chapter 1	Introduction.....	1
1.1	Introduction: why is it important and difficult to determine the benefits of expansion projects?	2
1.2	Scope and objective of the thesis	8
1.3	Possible real-life applications of the proposed method	10
1.3.1	Ranking or identifying priority projects	10
1.3.2	Applications related to the approval and fine-tuning of the projects to undertake.....	11
1.3.3	Categorize expansion projects: understand its objective/function.....	11
1.3.4	Cost allocation: beneficiary pays principle.....	12
1.4	Outline of the document	13
Chapter 2	State of the art and critical review	15
2.1	Introduction	16
2.2	Estimating the benefits of expansion projects. What has been done so far?	16
2.2.1	Traditional approach	17
2.2.2	ENTSO-E approaches: TOOT and PINT.....	18
2.2.3	Shapley Value	21
2.3	Characteristics required for a methodology to determine the benefits and beneficiaries of transmission expansion projects and critical review of existing methodologies.....	23
2.3.1	Benefits should take into account interactions among expansion projects.....	24
2.3.2	Benefits should not depend on the order of deployment of projects in the plan (or assume a specific order).....	26
2.3.3	Benefits assigned to projects are a function of the changes these, and other projects in the plan, produce in the network, and not of how the investments are clustered into projects	28

2.3.4	The benefit assessment methodology should be applicable to real-life systems and large expansion plans	32
2.3.5	The benefit assessment methodology should be easy to understand	33
2.4	Conclusions.....	33
Chapter 3	Methodology for benefit analysis.....	35
3.1	Introduction	36
3.2	Methodological framework to determine the benefits and beneficiaries of transmission expansion projects	38
3.2.1	Overview of the method.....	38
3.2.2	Considering expansion projects as players of the Aumann-Shapley game.....	40
3.2.3	Mathematical formulation of the economic dispatch problem.....	41
3.2.4	General implementation of the method.....	43
3.3	Particularization of the methodology to estimate the economic benefits produced by expansion projects in the operation of the power system	46
3.3.1	Description of the methodology to determine the benefits of expansion projects	47
3.3.2	Description of the methodology to determine the benefits obtained by individual users from expansion projects	55
3.3.2.1	Continuous benefits obtained by network users from expansion projects	58
3.3.2.2	Discrete benefits obtained by network users from expansion projects...	59
3.4	Particularization of the AS method to estimate the contribution of expansion projects to other types of benefits related to the operation of the power system.....	69
3.5	Complying with the requirements of a sound analysis of the benefits of projects: assessment of the Aumann-Shapley method	75
3.5.1	Benefits should take into account interactions among expansion projects.....	75
3.5.2	Benefits should not depend on the order of deployment of projects in the plan (or assume a specific order).....	76
3.5.3	Benefits assigned to projects are a function of the changes these, and other projects in the plan, produce in the network, and not of how the investments are clustered into projects.....	76

3.5.4	The benefit assessment method should be applicable to real-life systems and large expansion plans	78
3.5.5	The benefit assessment methodology should be easy to understand	79
3.6	Conclusions.....	79
Chapter 4	Case studies	81
4.1	Introduction	82
4.2	Case study: 9-bus power system.....	83
4.2.1	Optimal dispatch of the power system.....	87
4.2.2	Estimating the benefits of expansion projects using the different methods discussed.....	90
4.2.3	Analysis and discussion.....	94
4.3	Case study: 118-bus power system	97
4.3.1	Estimating the benefits of individual expansion projects and computing their ranking.....	99
4.3.2	Selecting priority projects	101
4.3.3	Understanding the objective/purpose of expansion projects.....	103
4.3.4	Who is benefiting from expansion projects?	106
4.3.5	Cost allocation: “beneficiary pays” principle.....	110
4.3.5.1	Cost allocation at individual network user level, within a perfectly integrated system	112
4.3.5.2	Cost allocation at multi-system, or multi-country, level	115
4.4	Conclusions.....	122
Chapter 5	Conclusions, contributions and future research.....	125
5.1	Summary and conclusions.....	126
5.2	Contributions	128
5.3	Future research.....	131
5.3.1	Benefits estimation	131
5.3.2	Definition of expansion projects	131
5.3.3	Cost allocation.....	132

5.3.4	Priority expansion projects	133
Appendix A Sensitivities of system variables and dual variables.....		135
A.1	Introduction	136
A.2	Sensitivities of system variables and dual variables with respect to changes in the capacity of assets	138
A.3	Sensitivities of system variables and dual variables with respect to changes in the admittance of assets.....	138
A.4	Sensitivities of system variables and dual variables with respect to changes in the capacity and the admittance of assets when they are related through a one-to-one correspondence.....	139
Appendix B Implementations for efficient computation.....		141
B.1	Introduction	142
B.2	Compute sensitivities of system variables and dual variables efficiently	142
B.3	A more efficient implementation of the AS method proposed.....	144
B.3.1	The expansion plan affects both the capacity and admittance of transmission assets	145
B.3.2	The expansion plan only affects the capacity of transmission assets	146

List of Tables

Table 2.1. Operational costs [€M/year] in the situations considered for the PINT and TOOT methodologies.....	20
Table 2.2. Dispatch benefits [€M/year] of the expansion projects computed using the PINT and TOOT methodologies.....	20
Table 2.3. Dispatch benefits [€M/year] of the expansion projects computed using the Shapley methodology	23
Table 2.4. dispatch benefits [€M/year] of the expansion projects computed using the different approaches reviewed.....	25
Table 2.5. Dispatch benefits [€M/year] of the expansion projects computed using the different approaches reviewed.....	30
Table 2.6. Main characteristics of the benefit assessment methodologies considered.....	34
Table 3.1. Applications of the Aumann-Shapley approach in the power sector	37
Table 3.2. Dispatch benefits [€M/year] obtained by the users of the power system from each expansion project using the method proposed.....	67
Table 3.3. Dispatch benefits [€M/year] obtained by the users of the power system from each expansion project using AS without the allocation of the discrete benefits of network users.....	68
Table 3.3. Dispatch benefits [€M/year] of the expansion projects computed using the several methods reviewed and the AS method proposed.....	75
Table 3.4. Dispatch benefits [€M/year] of the expansion projects computed using the several approaches reviewed and the AS method proposed when projects AB1 and AB2 are considered.....	77
Table 4.1. Network data for the 9-Bus system.....	85
Table 4.2. Generation and demand data for the 9-bus system	86
Table 4.3. Economic dispatch without/with the transmission expansion plan in place.....	87
Table 4.4. Benefit [€M/yr] obtained by each generator and consumer from the TEP.....	88
Table 4.5. Benefit [€M/yr] obtained by each TO from the TEP	88
Table 4.6. Benefits [€M/yr] obtained by consumers from each TEP project using the AS approach	90

Table 4.7. Benefits [€M/yr] obtained by consumers from each TEP project using the PINT approach	91
Table 4.8. Benefits [€M/yr] obtained by consumers from each TEP project using the TOOT approach	91
Table 4.9. Benefits [€M/yr] obtained by generators from each TEP project using the AS approach	92
Table 4.10. Benefits [€M/yr] obtained by generators from each TEP project using the PINT approach	92
Table 4.11. Benefits [€M/yr] obtained by generators from each TEP project using the TOOT approach	93
Table 4.12. Benefits [€M/yr] obtained by TOs from each TEP project using the AS approach	93
Table 4.13. Overall dispatch benefits [€M/year] produced by expansion projects and their ranking according to the benefit to cost ratio computed for each project according to each method	100
Table 4.14. Priority projects selected using the AS method proposed	103
Table 4.15. Change, with respect to the situation where none of the expansion projects is deployed, taking place in the different types of benefits considered for the 118-bus power system resulting from the deployment of the priority expansion projects (computed using the AS method)	104
Table 4.16. Distribution of the overall dispatch benefits [€M/year] produced by the priority expansion projects as a whole among generators, consumers and transmission owners	107
Table 4.17. Network users obtaining the largest (positive and negative) benefits [€M/yr] from each expansion project. Generators are identified with a “G”, consumers are identified with a “C”, and the number of the node where they are located	109
Table A.1. Situations considered for the splitting of expansion projects	136

List of Figures

Fig. 1.1. Onshore and offshore primary wind energy resources in the USA. Source: NREL.	2
Fig. 1.2. Historical and forecasted transmission investments in the USA (Chang & Pfeifenberger 2016).....	3
Fig. 1.3. AC and DC reinforcements in the EU-MENA region forecasted for the period between 2022 and 2030 [GW] as computed by the Desertec Initiative (Godron et al. 2014).....	6
Fig. 1.4. Offshore grid designs (3E et al. 2011).....	7
Fig. 2.1. Situations compared when using the TOOT and PINT methodologies. The original network, in a), is represented with continuous lines, while the expansion plan proposed, in b), is represented with dashed lines. The ‘With’ and ‘Without’ situations employed when using TOOT and PINT are represented in c)-f). The expansion project whose benefits are to be assessed is indicated in red.	19
Fig. 2.2. 3-bus power system schematic representation.....	20
Fig. 3.1. Simplified scheme of application of the proposed method to determine the benefits of individual expansion projects for each time period t considered. All data required to calculate project’s benefits is obtained by solving K optimal power flow and economic dispatch problems.	51
Fig. 3.2. 3-bus power system schematic representation. This power system was first introduced in Chapter 2.	52
Fig. 3.3. Evolution of the production of the different generator units (continuous lines and left axis) and the power flow of the expansion projects (dashed lines and right axis) through all the steps k of the application of the AS approach (gradual deployment of the plan simulated in AS).....	53
Fig. 3.4. Evolution of the nodal prices through all the steps k of application of the AS approach (gradual deployment of the plan simulated in AS).	53
Fig. 3.5. Evolution of the marginal benefits provided by expansion projects through all the steps k of application of the AS approach (gradual deployment of the plan simulated in AS).	54

- Fig. 3.6. Simplified scheme of application of the proposed method to determine the beneficiaries of individual expansion projects, and the benefits that each network user (beneficiary) obtains from each project, for each time period t considered. All data required to calculate project's beneficiaries is obtained by solving K optimal power flow and economic dispatch problems. 63
- Fig. 3.7. Evolution of the benefits of the whole system (dashed line measured on the left axis) and their rate of change, or slope (continuous line measured on the right axis), throughout all the steps k of application of the AS method (gradual deployment of the plan simulated in AS). Changes in the basis of the problem are indicated with an *. 65
- Fig. 3.8. Discrete benefits obtained by users from the change in the problem basis *1. Consumers located in node A are the most favored by this, due to the resulting reduction taking place in the price of this node. 66
- Fig. 3.9. Contribution of each expansion project to the change of the production of unit A1 through all the steps k of the application of the AS method (gradual deployment of the plan simulated in AS). 66
- Fig. 3.10. Simplified scheme of application of the proposed method to determine the amount of benefits of several types produced by individual expansion projects for each time period t considered. All data required to calculate project's benefits –of the different types of them– is obtained by solving K optimal power flow and economic dispatch problems. 73
- Fig. 3.11. Contribution of each expansion project to the integration of RES generation (continuous lines and left axis) and the reduction of CO₂ emissions (dashed lines and right axis) through all the steps k of the application of the AS algorithm (gradual deployment of the plan). 74
- Fig. 4.1. 9-Bus power system schematic representation. The original network is depicted in continuous lines, while the new projects to be installed are depicted in dashed lines. 84
- Fig. 4.2. 118-Bus power system schematic representation. The original network in the system is depicted using black lines, while TEP projects are depicted using red lines. 99
- Fig. 4.3. Evolution with the network expansion budget of the net system benefits [€M/yr] resulting from the deployment of priority projects. The evolution of the net benefits obtained for the re-computed expansion plans complying with the different budget limits are represented with dashed lines. 102
- Fig. 4.4. Increase achieved by expansion projects, with respect to the situation where none of the expansion projects is deployed, in the amount of RES electricity produced (blue points), which is represented considering the left axis, and reduction of CO₂ emissions

achieved by these projects (orange crosses), which is represented considering the right axis.....	106
Fig. 4.5. Economic dispatch benefits provided by each expansion project differentiated by the type of user: generators, consumers and transmission owners.	107
Fig. 4.6. Economic dispatch benefits obtained by each zone from each expansion project, as computed using AS. From each expansion project, the benefits of a zone are the sum of the benefits (positive and negative) obtained by the individual network users within this zone from that project.....	110
Fig. 4.7. Allocation of the costs of each expansion project, in percentage, to the different sets of network users considered (generators, consumers and TOs) without paying any compensation to the network users obtaining negative benefits from projects. Although aggregated in order to display the results, each network user is considered separately..	113
Fig. 4.8. Allocation of the costs of each expansion project, in percentage, to the individual network users when no compensation is being paid to the network users obtaining negative benefits from projects. Only network users having to pay 5% or more of the costs of each expansion project are listed here. Costs paid by generatos are displayed with horizontal lines, costs paid by consumers are displayed with vertical lines and those paid by TOs are displayed with plain colours.	114
Fig. 4.9. Allocation of the costs of each expansion project, in percentage, to the zones defined in the power system, when no compensation is paid to the zones negatively affected by each project.....	119
Fig. 4.10. Final net benefits obtained by each zone from each expansion project (benefits of the zone minus the cost allocated the zone) when no compensation is made to the zones negatively affected by expansion projects.	119
Fig. 4.11. Allocation of the costs of each expansion project to the zones defined in the power system, [% of the augmented costs (including compensations) of each project]. Negative figures indicate that a compensation of the corresponding magnitude is being paid to the corresponding zone.....	121
Fig. 4.12. Final net benefits obtained by each zone from each expansion project (benefits of the zone minus the cost allocated to it) when the cost allocation scheme considers that compensations are paid to the zones obtaining negative benefits from this project.	122
Fig. B.1. Simplified scheme of the application of the method to determine the beneficiaries of individual expansion projects for each time period t considered. All required data to calculate project's beneficiaries is obtained by solving K optimal power flow and economic dispatch problems. This figure corresponds to Fig. 3.6 in Chapter 3.....	143

Fig. B.2. Evolution of the marginal benefits provided by expansion projects through all the steps k of application of the AS approach (gradual deployment of the plan simulated in AS). Changes in the basis of the problem are indicated with an *. The original figure corresponds to Chapter 3 (Fig. 3.5), and belongs to the illustrative example employed through this thesis. 147

Nomenclature

SET AND INDICES

Symbol	Interpretation
g	Generation unit
t	Time period
c	Consumer of the network
i, j	Nodes of the network
$l(i, j)$	Line connecting nodes i and j

PARAMETERS

Symbol	Interpretation	Units
VB_c	Utility (benefit) obtained by consumer c from the electricity it consumes	[€M/MW]
VC_g	Variable production cost of unit g	[€M/MW]
$CO2Cost$	Per unit cost of CO ₂ emissions	[€M/MCO ₂]
$ECO2_g$	CO ₂ emission rate of unit g	[MtCO ₂ /MW]
$ENSCost_i$	Unit cost of ENS at node i	[€M/MWh]
$y_{l(ij)}$	Admittance of line l	[p.u.]
$\overline{F}_{l(ij)}$	Power flow capacity of line l	[MW]
\overline{GP}_g	Maximum power production of unit g	[MW]

$D_{i,t}$	Power consumption at node i in each time period t	[MW]
W_t	Weight (or duration) of time period t	[h/yr]

VARIABLES

Symbol	Interpretation	Units
$gp_{g,t}$	Power production of unit g in each time period t	[MW]
$ens_{i,t}$	Amount of energy demanded by a consumer in node i that is not served in each time period t	[MW/h]
$f_{l(ij),t}$	Power flow through line l , which connects nodes i and j , in each time period t	[MW]
$\theta_{i,t}, \theta_{j,t}$	Voltage angles of nodes i and j , respectively, in each time period t	[rad]
$\tau_{f,l,t}$	Dual variable of the equation determining the flow through l in time period t (2 nd Kirchhoff law)	[€M/MW]
$\gamma_{f,l,t}^+, \gamma_{f,l,t}^-$	Dual variables of the equation setting the upper and lower limit to the flow through l in time period t	[€M/MW]
$\mu_{i,t}$	Marginal price at node i in time period t	[€M/MWh]

OUTPUTS

Symbol	Interpretation	Units
$\Delta Ben_k^{l,t}$	System benefits produced by project l , in time period t , occurring in step k of the AS algorithm	[€M/h]
$Ben^{l,t}$	System benefits produced by project l in time period t	[€M/h]

Ben^l	Total System benefits produced by project l	[€M/yr]
GB_g^t	Benefits of generator g in the dispatch in time period t	[€M/h]
CB_c^t	Benefits of consumer c in the dispatch in time period t	[€M/h]
TB_l^t	Benefits of TO of line l in the dispatch in time period t	[€M/h]
$\Delta GB_g^{k,t}$	Discrete change in the benefits of generator g , in time period t , produced in step k of the AS algorithm	[€M/h]
$\Delta CB_c^{k,t}$	Discrete change in the benefits of consumer c , in time period t , produced in step k of the AS algorithm	[€M/h]
$\Delta TB_l^{k,t}$	Discrete change in the benefits of the TO of line l , in time period t , produced in step k of the AS algorithm	[€M/h]
$Vgp_{g'}^{l,t}$	Total change caused by project l in the production of g' in time period t	[MW]
$Vens_{c'}^{l,t}$	Total change caused by project l in the ENS of consumer c' in time period t	[MWh]
$Vf_{l''}^{l,t}$	Total change caused by project l in the flow through line l'' in time period t	[MW]
$Cgp_{g'}^{l,t}$	Relative contribution of project l to the change in the production of g' in time period t	[%]
$Cens_{c'}^{l,t}$	Relative contribution of project l to the change in the ENS of consumer c' in time period t	[%]
$Cf_{l''}^{l,t}$	Relative contribution of project l to the change in the flow through line l'' in time period t	[%]
$DGB_{g,k}^{l,t}$	Discrete benefits of generator g produced by project l , in time period t , occurring in step k of the AS algorithm	[€M/h]
$DCB_{c,k}^{l,t}$	Discrete benefits of consumer c produced by project l , in time period t , occurring in step k of the AS algorithm	[€M/h]

$DTB_{l,k}^{l,t}$	Discrete benefits of TO l' produced by project l , in time period t , occurring in step k of the AS algorithm	[€M/h]
$GB_g^{l,t}$	Benefits of generator g produced by project l in time period t	[€M/h]
$CB_c^{l,t}$	Benefits of consumer c produced by project l in time period t	[€M/h]
$TB_{l'}^{l,t}$	Benefits of TO l' produced by project l in time period t	[€M/h]
GB_g^l	Total benefits of generator g produced by project l	[€M/yr]
CB_c^l	Total benefits of consumer c produced by project l	[€M/yr]
$TB_{l'}^l$	Total benefits of TO l' produced by project l	[€M/yr]
$SoSB^t$	Security of Supply level in time period t	[GWh/h]
$CO2B^t$	CO ₂ emissions level benefit in time period t	[MtCO ₂ /h]
$RESB^t$	RES integration level in time period t	[GW]
$\Delta SoSB_k^{l,t}$	Security of Supply benefits produced by project l , in time period t , occurring in step k of the AS algorithm	[GWh/h]
$\Delta CO2B_k^{l,t}$	CO ₂ emissions benefits produced by project l , in time period t , occurring in step k of the AS algorithm	[MtCO ₂ /h]
$\Delta RESB_k^{l,t}$	RES integration benefits produced by project l , in time period t , occurring in step k of the AS algorithm	[GW]
$SoSB^{l,t}$	Security of Supply benefits produced by project l in time period t	[GWh/h]
$CO2B^{l,t}$	CO ₂ emissions benefits produced by project l in time period t	[MtCO ₂ /h]
$RESB^{l,t}$	RES integration benefits produced by project l in time period t	[GW]
$SoSB^l$	Total Security of Supply benefits produced by project l	[GWh/yr]

$CO2B^l$	Total CO ₂ emissions benefits produced by project l	[MtCO ₂ /yr]
$RESB^l$	Total RES integration benefits produced by project l	[GWh/yr]

ABBREVIATIONS

Symbol	Interpretation
---------------	-----------------------

ACER	Agency for the Cooperation of Energy Regulators
AS	Aumann-Shapley
B/C	Benefit to Cost ratio
CAISO	California Independent System Operator
CBA	Cost-Benefit Analysis
CO ₂	Carbon dioxide
CSW	Continental South-West
DER	Distributed Energy Resources
EC	European Commission
ED	Economic Dispatch
ENS	Energy Not Served
ENTSO-E	European Network of Transmission System Operators for Electricity
EU	European Union
FACTS	Flexible Alternating Current Transmission System
IEM	Internal Energy Market
MENA	Middle East and North of Africa
NRA	National Regulatory Authority

OPF	Optimal Power Flow
PCI	Projects of Common Interest
PINT	Put IN one at a Time
RES	Renewable Energy Source
RHS	Right Hand Side
RTO	Regional Transmission Organization
SoS	Security of Supply
SW	Social Welfare
TEP	Transmission Expansion Plan
TOOT	Take Out One at a Time
TO	Transmission Owner
TSO	Transmission System Operator
TYNDP	Ten-Year Network Development Plan
USA	United States of America
VPP	Virtual Power Plant

Chapter 1

Introduction

This introductory chapter provides the general background that motivates this thesis work and discusses its objectives. This is related to the need of a benefit analysis methodology for transmission expansion projects when considered as part of an expansion plan, or group of projects. The first section of this chapter explains the context of this thesis work. Secondly, the scope and objective of the thesis are laid out. The third section illustrates some applications of the work developed in this thesis. Finally, the structure of this document is presented in the last section.

1.1 INTRODUCTION: WHY IS IT IMPORTANT AND DIFFICULT TO DETERMINE THE BENEFITS OF EXPANSION PROJECTS?

The increasing concern about climate change is creating new challenges to be faced by the power sector, which make its analysis more interesting. The current international climate change strategy has led many countries to incentivize, or mandate, the adoption of cleaner and more efficient energy technologies. The international community has agreed to achieve a drastic reduction in CO₂ emissions and a huge increase in the production of electricity with renewable technologies. In fact, the European Union (EU) has set very aggressive emission reduction targets, establishing a 20% reduction in greenhouse gases with respect to 1990 levels by 2020 and a target of an 80% reduction in these emissions and 100% clean electricity production by 2050 (European Commission 2011b; European Climate Foundation 2010). This shift from a fossil fuel system to a low-carbon economy is changing the shape of power systems. This change must be driven, together with the increases in energy efficiency, by the deployment of large amounts of RES generation in the medium and long term future. But RES generation is located where natural primary energy resources are available, typically far away from large populated areas (see Fig. 1.1). Moreover, the amount of RES generation capacity to be deployed is so large that it will affect the cross-border flows of the regions involved. Thus, the integration of this generation will require large additional network investments (Kassakian et al. 2011), (Purvins et al. 2011).

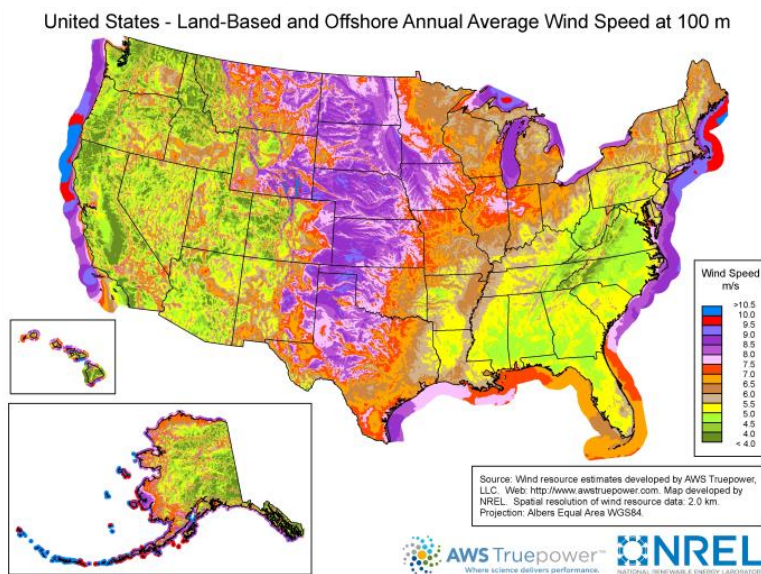

Fig. 1.1. Onshore and offshore primary wind energy resources in the USA. Source: NREL.

This need for transmission investments has been acknowledged both in the USA and in the EU as a relevant challenge to face. Transmission investments, deployed under the FERC jurisdiction, in the USA increased up to \$15-20 billion/year in the last years (see Fig. 1.2). Moreover, the transmission network investments forecasted in the USA for the next decade amount to \$120-160 billions, including expansion projects with several purposes (namely, the increase in system reliability, the connection of new resources: and the upgrade or replacement of old facilities) (Chang & Pfeifenger 2016). In Europe, the last Ten Year Network Development Plan (TYNDP) for 2016 foresees about €150 billion of network investments for the period concerned, including 200 expansion projects (ENTSO-E 2016).

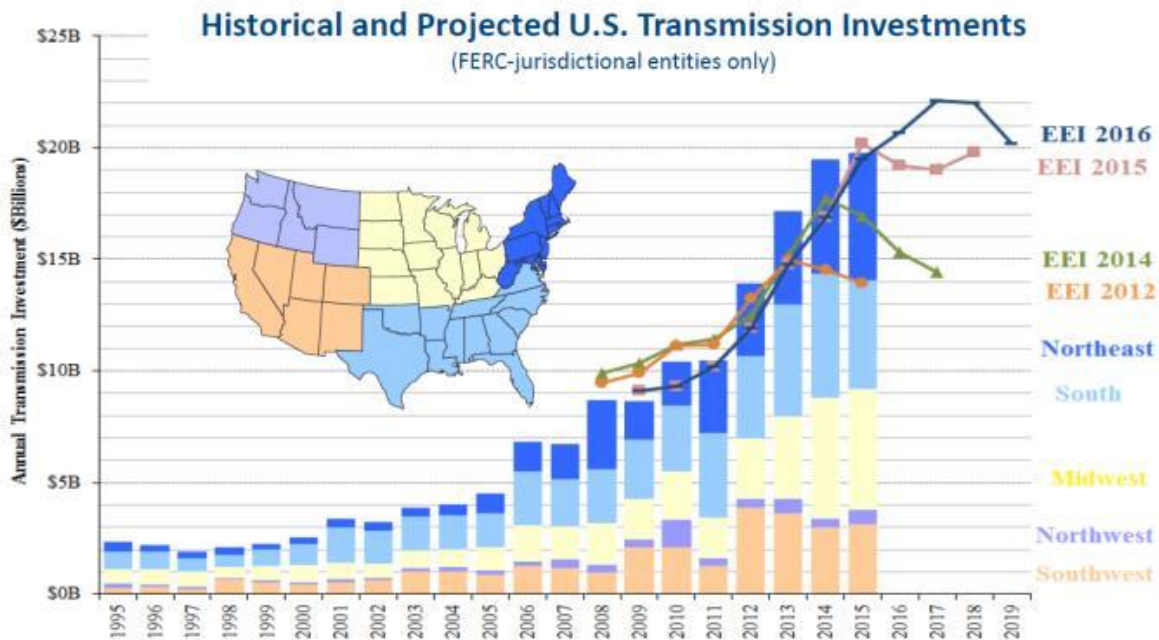

Fig. 1.2. Historical and forecasted transmission investments in the USA (Chang & Pfeifenger 2016).

The European Commission (EC) has indicated that, under the current regulatory frameworks, authorities in power systems run the risk of not being able to achieve the undertaking of the required investments (European Commission 2011a)¹. The main

¹ The prediction made by the EC in (European Commission 2011a) has been confirmed to some extent. According to (ENTSO-E 2014), about 53% of the expansion projects in the pan-EU list of significance projects of the CSW (Continental South-West) region in the TYNDP-2012 are delayed, rescheduled or cancelled.

identified barriers that jeopardize the deployment of these infrastructures concern the lack of an appropriate regulatory treatment and the lack of social acceptance (Battaglini et al. 2012).

From a regulatory perspective, permitting and approval processes have been detected as two major difficulties that drive up the costs and the uncertainty in the deployment of transmission projects. In the current economic context, the lack of suitable financing sources (Henriot 2013) has also emerged as an important barrier that stops the deployment of the required infrastructures. The allocation of the costs of these projects to the projects' users or beneficiaries (either at individual agent or at system level), which has always been one of the main obstacles to achieving the construction of required network reinforcements², should still be taken into account as one main aspect of regulation to be analyzed in this regard. The relevance of network cost allocation is to be emphasized in the new context, since a big part of the required transmission investments will affect the operation of the power system in several countries or States.

The lack of social acceptance (and political support) is one of the main sources of delay, and even cancelation, of new transmission lines³. Authors in (Ciupuliga & Cuppen 2013) investigate several ways of fostering the acceptance of transmission projects through participation. They state that the interaction between the project developer and the local stakeholders plays an essential role to improve the community acceptance of the projects. Besides, (Buijs et al. 2011) evaluates different technological alternatives that may have less public opposition or less complicated authorizations procedures.

Some states of the EU have started to address this risk by developing dedicated regulatory frameworks for important investment projects (Meeus & Keyaerts 2014). The European Commission has also recognized the problem, establishing a process to identify the projects that provide a high-value to the Internal Electricity Market (IEM) of the EU. These projects are labeled as Projects of Common Interest (PCI) and are subject to a facilitated permit granting process and improved regulatory treatment to ensure their deployment (European Union 2013). The question that arises next is how to identify these priority projects. In previous EU policy packages, priority projects are defined through negotiation between the EU and Member States. However, in the recent regulation

² Many of the proposed cost allocation methods proposed in the literature do not comply with one of the basic principles of transmission pricing (Pérez-Arriaga 2013): allocating costs of transmission assets in proportion to the benefits that each agent or system is expected to obtain from the former ("Beneficiary pays" principle).

³ For example, the Matera-Santa Sofia transmission line in the South of Italy took almost 20 years to be completely deployed due to local opposition.

(European Union 2013), the EC indicated that these projects should be identified based on the results of a Cost-Benefit Analysis (CBA).

Moreover, current EU regulation also tries to solve the cost allocation problem by dictating that national regulatory authorities shall have available only six months to agree on the cost allocation of sufficiently mature and important projects. If they cannot agree, the Agency for the Cooperation of Energy Regulators (ACER) is expected to decide, on their behalf, the cost allocation to implement using the *beneficiaries pay principle*⁴. A similar approach has also been established in the USA, where the Federal Energy Regulatory Commission (FERC) requires that the cost of transmission investments be allocated to market agents and systems based on the benefits they are expecting to obtain from the former (Federal Energy Regulatory Commission (FERC) 2012)⁵.

Nonetheless, determining the benefits of expansion projects and identifying the stakeholders (beneficiaries) obtaining these benefits is not an easy task (Wu et al. 2006). Traditionally, the expansion of the network was performed by vertically-integrated utilities whose primary purpose was to guarantee the supply of the demand with an adequate reliability level. Therefore, the main driver of the expansion of the transmission network was the need to meet the established reliability standards.

Recent regulations established by the corresponding authorities in both the EU and the USA have fostered research in this topic. Hence, a significant amount of work has been carried out in the last years to identify and describe the benefits of transmission expansion projects (Chang et al. 2013; Chamorro et al. 2012; Bresesti et al. 2009; CAISO 2004). Nonetheless, limited attention has been paid to developing a comprehensive methodology to determine the benefits that each stakeholder, or national/local system, is expected to obtain from expansion projects, especially when they are part of large expansion plans. Typically, the benefits of projects and their beneficiaries are assessed for the whole plan, and not for each individual project (Fürsch et al. 2013; Krishnan et al. 2013). However, the allocation, or assignment, of the benefits of the whole expansion plan to each of the individual projects that comprise it remains largely unexplored.

Furthermore, although a huge amount of RES generation has been installed in the past few years, it is expected that much more new RES generation will be installed in the near future. In fact, some of these new RES generation deployments are planned as part of

⁴ Details on the first decisions on cross-border cost allocation for PCI projects can be consulted in (Meeus & Keyaerts 2015).

⁵ FERC Order 1000 requires that “*The cost of transmission facilities must be allocated to those within the transmission planning region that benefit from those facilities in a manner that is at least roughly commensurate with estimated benefits*”.

larger coordinated projects. For example, Desertec (Zickfeld et al. 2013) is an initiative that proposes to install large amounts of renewable generation capacity in the north of Africa to export part of the electricity it produces to Europe. The network expansion required for this is displayed in Fig. 1.3. Another example is the OffshoreGrid project, which is studying the deployment of an interconnected offshore network to accommodate the production of the large off-shore wind farms that may be built in the North and Baltic Seas (see Fig. 1.4).

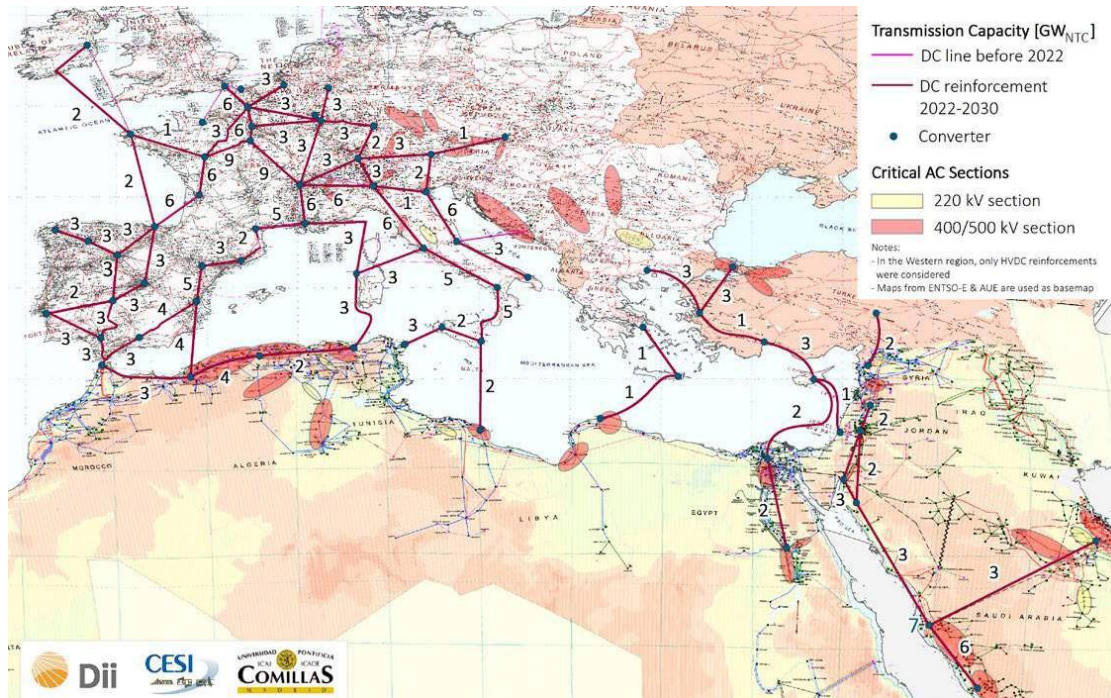

Fig. 1.3. AC and DC reinforcements in the EU-MENA region forecasted for the period between 2022 and 2030 [GW] as computed by the Desertec Initiative (Godron et al. 2014).

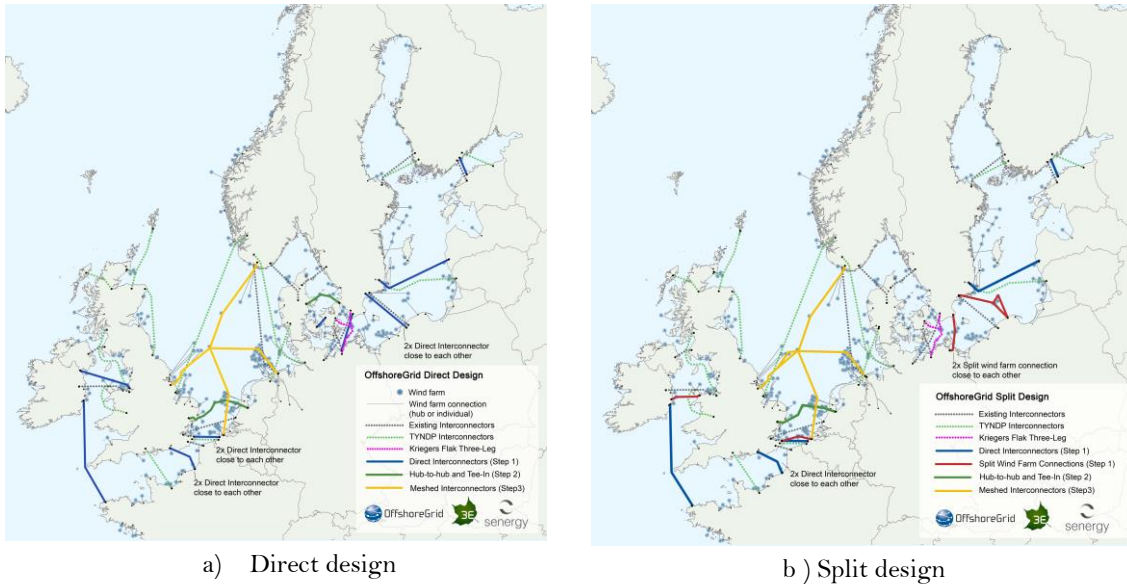

Fig. 1.4. Offshore grid designs (3E et al. 2011).

The expansion of the network to integrate large RES projects, or to integrate the RES generation located over other areas in a more efficient manner, requires coordinating the expansion of the network over larger areas or regions. The TYNDP in Europe is an example of the efforts made to coordinate the expansion of the network over larger regions. In this case, the coordination is currently being made using a bottom-up approach. However, there are some efforts to perform this coordination using, instead, a top-down approach. Thus, for instance, the eHighway2050 research project in the EU has aimed to develop a methodology to jointly, or centrally, plan the expansion of the network over the whole EU-region (Sanchis et al. 2015; Lumbreras, Ramos, Banez-Chicharro, et al. 2017)

The need to jointly assess the benefits produced by a multitude of projects planned over the next years/decades for wide regions, due to the interdependencies existing among these projects, adds to the complexity of the problem of determining the benefits of these expansion projects (Neuhoff et al. 2012). The fact that the expansion of the network is undergoing a process of coordination over wider regions is complicating, even more, the determination of the benefits and beneficiaries of expansion projects.

Taking into account the current context in regional power systems and markets, and the foreseeable future, I outline in the next paragraphs the scope and objectives pursued in my thesis work, as well as the relevant real-life applications it may have.

1.2 SCOPE AND OBJECTIVE OF THE THESIS

As explained, although significant research efforts have been made in the past aimed at the assessment of the benefits produced by network expansion projects, the main focus of previous works is on the definition of the types of benefits produced in the expansion of the transmission network. However, little work has been focused on the computation of the individual contribution of each expansion project to the benefits produced by the whole expansion plan. The final objective of this thesis is to complement previous works by developing a methodology able to assess the benefits and beneficiaries produced by transmission expansion projects within a plan. This final objective can be decomposed into several, more specific, partial ones, which are detailed next:

- 1) Review existing –and currently applied– methods for the benefit analysis of expansion projects.
- 2) Discuss the main characteristics to be featured by a method to analyze the benefits provided by expansion projects, and the users of the network benefitting from these projects. The characteristics proposed should be consistent with the technical and economic principles behind the expansion of the network.
- 3) Propose a method for the analysis of the benefits provided by individual expansion projects within a plan, or group of projects. The methodology proposed should fulfill the characteristics described previously. Note that this not only involves computing the overall benefits produced by the expansion projects in the plan, or group, but also to determine the benefits obtained by the individual network users from these projects, and the contribution of these projects to the different types of benefits considered.
- 4) Implement the proposed methodology in a transmission expansion planning model⁶.
- 5) Apply the methodology proposed to a case study in order to verify its applicability and assess the soundness of the specific results obtained. In this regard, two different case studies shall be considered. A case study is to be used to describe the desirable properties of a benefit assessment method and illustrate the application of the proposed method. A larger case study, comprising 118 nodes, is analyzed to show the applicability of this proposed method to large systems, as well as the

⁶ The proposed methodology is implemented in the TEPES model (Long-Term Transmission Expansion Planning Model for an Electric System). This model is a decision support system developed by the IIT for defining the transmission expansion plan of a large electric system (Lumbreras, Ramos & Banez-Chicharro 2017).

possible real-life applications of these results. These include the allocation of the cost of new projects within the expansion plan and the identification of priority projects.

In order to achieve these objectives, this thesis has yielded several contributions. From a conceptual, or theoretical, point of view, the main contributions are listed next:

- Identification and discussion of the different properties that should be featured by a method to assess the benefits and beneficiaries produced by expansion projects within a plan. Then, existing methods are analyzed using these properties.
- Proposing a novel formulation of the Aumann-Shapley concept, where expansion projects are considered as players of the cooperative game.
- Identification of the continuous and discrete benefits produced by expansion projects in the cooperative game formulated. Then, separate games are formulated to allocate these benefits (continuous and discrete) to expansion projects.
- Formulation, for the first time, of the Aumann-Shapley game to the computation of the continuous benefits obtained by network users from expansion projects.
- Adaptations of the conventional Aumann-Shapley game to allocate to network users the discrete benefits produced by expansion projects, which has never been done. The discrete benefits of individual projects are those that do not evolve continuously with the size of projects but are realized all of a sudden once one or several of these projects have reached a certain size. Then, a method to determine which specific expansion projects are responsible of the discrete changes occurring in the benefits of users was devised.

From an application point of view, the main contributions of this thesis are:

- Proposing a method, based on the Aumann-Shapley concept, to determine the benefits and beneficiaries of the projects comprised in an expansion plan. The method proposed is consistent with the technical and economic principles that rule the expansion of the network.
- Implementation of the proposed method in a computationally efficient way. The proposed method is finally implemented in a transmission expansion planning model.
- Application of the proposed method to two case studies of different sizes.

The contributions just mentioned have resulted in two journal articles (Banez-Chicharro et al. 2017b; Banez-Chicharro et al. 2017a):

- F. Banez-Chicharro, L. Olmos, A. Ramos, and J. M. Latorre, “Estimating the benefits of transmission expansion projects: An Aumann-Shapley approach,” *Energy*, vol. 118, pp. 1044–1054, Jan. 2017.
- F. Banez-Chicharro, L. Olmos, A. Ramos, and J. M. Latorre, “Beneficiaries of Transmission Expansion Projects of an Expansion Plan: An Aumann-Shapley Approach,” *Applied Energy*, vol. 195, pp. 382–401, June 2017.

1.3 POSSIBLE REAL-LIFE APPLICATIONS OF THE PROPOSED METHOD

The estimates of the benefits obtained by individual network users, groups of them, of the system as whole, from each expansion project in a plan, or group of projects, may be applied to several main aspects of the organization and regulation of the expansion of the transmission grid. Some possible real-life uses of the benefits computed are described in the following sections.

1.3.1 Ranking or identifying priority projects

The benefits assigned to individual projects in the expansion plan –or group of projects– considered following the approach proposed in this thesis may be used to rank these projects according to their importance. This ranking of projects could be used to define priority projects in those regions where this is being done. We depict some situations in the EU context where the application of the methodology here developed to rank expansion projects should be useful.

At *national level*, local Transmission System Operators (TSOs) are usually responsible to plan the expansion of the grid in most EU countries. National TSOs individually carry out periodic planning studies to determine the network expansion that is required, with the objective of improving national system reliability or economic efficiency. The expansion plan obtained is then proposed to national regulatory authorities (NRA), which must decide on the approval of each expansion project proposed by TSOs. In this context, the authorities may employ the method developed to determine the relevance of the expansion projects proposed. Regulators can, then, give priority to the most beneficial projects.

At the *EU level*, project evaluation is accomplished by the planning entities in each of the regions defined. These entities are also responsible for the ranking of projects. Then, ACER (Agency for the Cooperation of Energy Regulators) gives its opinion on the ranking proposed by regions and, based on all this, the EC eventually defines the list of

PCI projects⁷. In this context, the methodology here developed could be used by the expansion planning entity in each region to compute the ranking of projects in this region. ACER could also use this methodology to determine the identity and features of projects in the final PCI list.

1.3.2 Applications related to the approval and fine-tuning of the projects to undertake

Third-party (merchant) projects are also allowed in the EU for interconnectors. The process in this case is similar to the national planning process: project promoters identify the need and propose the project to NRAs, which evaluate the proposal. Based in this evaluation, NRAs may approve the expansion project, reject it, or propose modifications to it and decide on the exemptions that have been required by the project promoters. Again, the methodology proposed here could be employed to evaluate these merchant proposals while taking also into consideration the regulated expansion plan, or investments, proposed by the TSO.

Although not specifically designed for this purpose, the method proposed could be applied to *modify the regulated transmission expansion plan*⁸. According to this, the estimates made of the benefits created by each project, computed in this case using the proposed approach, could potentially be used to determine whether each of these projects should actually be undertaken, or advice changes to be made to the projects originally defined. However, one should be aware that changing the set of projects to be undertaken would automatically result in a change in the benefits created by each project, according to most of the existing benefit assessment methods, including the one proposed in this thesis. Then, making use of the proposed approach to define the specific network investments to undertake could potentially lead to a development of the grid that departs from the most efficient one.

1.3.3 Categorize expansion projects: understand its objective/function

As previously argued, expansion plans normally comprise hundreds of projects. Moreover, as previously mentioned, the expansion of the network is currently evolving to include wider regions and involve a larger number of projects. As a consequence, the objective and function of transmission investments and expansion projects is less clear in the

⁷ In order to be labeled as a PCI, the expansion project has, at least, to: be necessary for the implementation of the energy infrastructure priority corridors and areas; be economic, social and environmental viable; involve at least two member states (crossing the border of one or more member states or being located in a member state and having a significant cross-border impact).

⁸ This approach was followed in (Contreras et al. 2009), as we will see with more detail in Chapter 2.

current context. Therefore, it would be interesting to understand the purpose, or function, of the individual expansion projects within a plan.

When ranking or identifying priority projects, only the global benefits created by expansion projects are computed. However, in order to understand the purpose of the individual expansion projects, and thus the expansion plan, it may be necessary to separately compute how much benefits of each type are expected to be produced by individual expansion projects⁹. Some specific types of benefits created by expansion projects that could be assigned to individual ones include the increase, or change, of the production of RES generation achieved through each expansion project (measuring the additional amount of RES generation it manages to integrate into the system), the reduction in energy losses, that in CO₂ emissions, or the increase in system security, achieved through each expansion project. The most relevant projects to integrate RES generation and increase system security (probably, the priority ones in many regions) could also be identified following the approach here proposed. For example, in the USA, reinforcements aimed at integrating RES generation have a priority status, as established in the Energy Policy Act, 2005, and the American Recovery and Reinvestment Act, 2009. Thus, the methodology here developed could be used to identify the contribution of each expansion project to the different types of benefits –somehow related to the SW– that are produced by the expansion plan.

1.3.4 Cost allocation: beneficiary pays principle

The costs of transmission investments are paid, directly or indirectly by the users of the network. In the case of *regulated* network investments, whose costs are recovered from network charges, there is the need to determine who should pay for transmission investments and how much. This involves the allocation of the costs of these projects to the users of the network using certain criteria. In the case of *merchant (third-party)* projects, still part of their cost could be recovered from network charges, depending on the agreement reached between the promoters and authorities to achieve their construction. Normally, a relevant fraction of the cost of these lines is recovered by investors from the congestion rents corresponding to these assets in the dispatch or the sale of rights to use these assets (Coxe & Meeus 2010).

⁹ For example, in the USA, transmission projects traditionally have been categorized by the primary purpose they serve: reliability, economic efficiency, or generator interconnection. A fourth category has recently appeared: public policy (for example, to meet renewable generation targets). These categories are explicitly recognized in FERC Order No. 1000.

There is a wide range of cost allocation methods applied to determine who should pay which fraction of the regulated costs of transmission assets. However, most of the existing methods do not allocate the regulated cost of each project in proportion to the benefits that each network user is expected to obtain from them (“beneficiary pays” principle), which is one of the basic principles that should guide network cost allocation (Rivier et al. 2013). This principle has been recently adopted by EU and US authorities in order to overcome some of the deployment problems of international or interregional expansion projects.

The allocation of the investment costs of expansion projects should be fair, efficient and provide strong enough incentives to achieve the construction of the investments required. At a *national or country level*, the cost allocation methodologies applied usually do not provide efficient economic signals to consumers and generators. Consumers normally pay for –almost– all the investment costs of expansion projects regardless of the benefits the former obtain from the latter. At a *regional or system level*, the cost of new infrastructures crossing a border is usually allocated to the countries or systems sharing this border on a 50%-50% basis. On the other hand, projects within a country are normally paid only by the network users located within this country. This may provide some counterproductive incentives for the construction of these projects. Both ACER and FERC, have recently regulated to solve this problem in the EU and the USA, respectively.

Therefore, the method proposed in this thesis may be employed by regulatory authorities to compute the fraction of the regulated costs of network investment projects that should be paid by each individual network user, or each country or state in a regional context, according to the benefits that this network user, or users in this country or state, are expected to obtain from these projects. Additionally, the method could be employed to determine the maximum remuneration to be perceived by investors in an expansion project, which should never exceed the benefits produced by this project¹⁰.

1.4 OUTLINE OF THE DOCUMENT

This document is structured in five chapters and three appendices in order to provide a comprehensive document whose structure is aligned with the objectives of the thesis.

In Chapter 2, a review of the existing methodologies to analyze the benefits, and beneficiaries of expansion projects is provided. After this review, the characteristics required for a methodology to accurately determine the benefits of expansion projects, and those obtained from them by the individual users of the network, are discussed. Previously

¹⁰ Please, see footnote 2.

proposed methods are analyzed in the light of these characteristics. In order to illustrate all the concepts discussed, a case example is employed throughout this chapter.

Chapter 3 is the core one in this thesis. It describes the method proposed for estimating the benefits of expansion projects, and the benefits obtained by the individual users of the system from these projects. After providing the methodological framework, the method proposed is particularized, i) first, to compute the economic benefits produced by expansion projects that are considered in the dispatch, and those of this type obtained by the individual network users, and ii) second, to determine the contribution of the individual expansion projects to the benefits of other types obtained by the system and the individual network users. The method proposed is finally assessed according to the desirable characteristics of it described in chapter 2.

In Chapter 4, several case studies of different sizes are analyzed using the proposed method. A first case study (9-bus power system) is analyzed in detail applying both the proposed method and the ones currently employed in the EU. After that, a second case study (118-bus power system) of a larger size is also considered. This allows one to apply the method proposed to a system of a real-life size in order to select the priority projects within the expansion plan, understand their objective (or function), and allocate their cost to the individual network users, or the several zones defined within the system, according to the “beneficiary pays” principle.

Finally, Chapter 5 provides the main conclusions and results of this thesis. This chapter also highlights the main contributions of this work and proposes several potential topics for further research.

Appendix A provides the reader with the main theoretical background required to compute the sensitivities of variables and dual variables of the optimal power flow and economic dispatch problems. These sensitivities are required for the application of the proposed methodology.

Appendix B discusses the main mathematical developments used in this thesis for the implementation of the proposed methodology. Making use of these developments allows to apply the method proposed in a computationally efficient way.

The data of the large case study analyzed in Chapter 4 is presented in Appendix C.

Chapter 2

State of the art and critical review

After the previous introductory chapter, where the importance and applications of estimating the benefits of individual expansion projects have been discussed, this chapter presents a review of what has been done so far to solve this problem. First, a review of existing methodologies is performed. Then, the characteristics that are required for a methodology to estimate correctly the benefits and beneficiaries of projects within an expansion plan are discussed. Existing methodologies are analyzed based on these characteristics. In order to clarify all the concepts, an illustrative example is presented.

2.1 INTRODUCTION

FERC Order No. 1000, issued on 21 July 2011 in the USA, states that the cost allocation of new transmission facilities must be assigned to the facilities' beneficiaries *"in a manner that is at least roughly commensurate with estimated benefits"* (Federal Energy Regulatory Commission (FERC) n.d.). In the European Union (EU), the Regulation (EU) No 347/2013 (European Union 2013) established in 15 May 2013 requests ENTSO-E to establish a *"methodology, including on network and market modelling, for a harmonised energy system-wide cost-benefit analysis at Union-wide level for projects of common interest"* (Art. 11). As acknowledged by these regulations, accurately computing the benefits provided by expansion projects, and the individual users that are benefiting from these projects must be a priority.

Although Cost-Benefit Analysis has a long tradition in Europe¹¹, transmission infrastructures in the power sector were traditionally built in order to meet some technical criteria (to ensure the reliability of the system) and not based on the costs and benefits of these infrastructures. Determining the benefits and beneficiaries of expansion projects is not an easy task, and it is becoming even more difficult.

This chapter deals with the problem of estimating the benefits of individual expansion projects within a plan, or group of projects, and the computation of the benefits obtained by individual users of the power system from these projects. As will be seen through this chapter, this is a difficult problem to solve and existing –and currently being applied– methodologies have not solved this issue correctly.

2.2 ESTIMATING THE BENEFITS OF EXPANSION PROJECTS. WHAT HAS BEEN DONE SO FAR?

The computation of the costs and benefits of transmission projects is not straightforward. A large number of works focus on the development of methodologies for the CBA of projects in a multiplicity of contexts, such as infrastructure investments (Florio et al. 2008) and smart grid projects (Giordano et al. 2012). Most research works focus on identifying and characterizing the types of benefits provided by expansion projects, or on

¹¹ The origin of CBA is traditionally attributed to the French engineer Jules Dupuit (1804-1866), and it was further developed by the British economist Alfred Marshall (1842-1924). However, the practical development of the CBA comes thanks to the Federal Navigation Act of 1936, which required that the projects to improve the waterway system were developed when the total benefits of a project to whomsoever they accrued exceed the costs of that project.

the measurement and comparison of benefits of different kinds. A comprehensive catalog of potential benefits of expansion projects is presented in (Chang et al. 2013). Authors in (Nooij 2011) carry out a CBA of two new EU interconnections and provide recommendations for further research. The CBA methodology developed in California by CAISO (CAISO 2004) is an important reference in this field. The EU has also funded numerous research projects to estimate the benefits and costs of projects. Cost-benefit analysis methodologies have been developed in (Migliavacca et al. 2011) and (Sanchis et al. 2015). The authors in (Migliavacca et al. 2011) provide a methodology to jointly consider all types of benefits of infrastructure investments in the EU, while the authors in (Sanchis et al. 2015) jointly determine the benefits of a set of projects to be deployed in the long-term leading to a transformed network.

2.2.1 Traditional approach

Typically, when analyzing large transmission expansion plans (TEP) or groups of projects¹², benefits are assessed for the whole plan, and not for each individual project in it. Then, the systems costs in the situation where the whole plan is implemented (Fig. 2.1-b) are compared to the costs where no project of this plan is deployed (Fig. 2.1-a). However, the allocation of the benefits of the whole expansion plan to each one of the individual expansion projects that comprise it remains largely unexplored.

A growing number of authors highlights the need to assess the benefits of each specific project as part of a TEP to be deployed in a certain time frame (Neuhoff et al. 2012) or the potential of these projects for bringing these benefits depending on the different uncertainties present, such as the Real Options Valuation approach in (Lumbreras et al. 2016). Assessing the benefits of projects as part of a plan –or group of projects– implies taking into account interactions occurring among these projects. Ignoring these interactions may imply misestimating the effects of expansion projects on the system operation. Thus, the CBAs of projects that are carried out on an individual project basis may be deemed inappropriate. The benefits of individual projects have been traditionally determined adopting a simple, though arguably inaccurate, approach. This involves comparing the system social welfare (SW) in two operation situations: the so-called “with” situation, where the expansion project being assessed is deemed to be in place in the system, and the “without” situation, where this project is considered not to be deployed.

¹² A transmission expansion plan can be obtained as a whole (top-down approach) (Lumbreras et al. 2015) or by joining different groups of projects (bottom-up approach) (ENTSO-E 2014). The methodology proposed here can be applied in both cases.

2.2.2 ENTSO-E approaches: TOOT and PINT

In order to overcome the lack of research in this field, ENTSO-E¹³ proposes two approaches to estimate the benefits created by each expansion project within a set of them in its CBA methodology (ENTSO-E 2013): the Take Out One at a Time (TOOT) and the Put In one at a Time (PINT) methodologies. In the TOOT methodology¹⁴, the benefits produced by each expansion project are computed comparing the operation of the system in the situations with and without this project while assuming that the rest of the expansion projects proposed have already been undertaken. Thus, the benefits of each expansion project are calculated according to (2.1). On the other hand, in the PINT methodology¹⁵, the benefits of the concerned project are computed by comparing the operation of the system with and without this project when none of the rest of projects considered has been undertaken, as in (2.2). The situations compared when using the PINT and TOOT methodologies are represented in Fig. 2.1 (c-f).

$$Ben_{TOOT}^l = SW_w^{TEP} - SW_{wo}^{TEP} \quad \forall l \in TEP \quad (2.1)$$

$$Ben_{PINT}^l = SW_w^{\emptyset} - SW_{wo}^{\emptyset} \quad \forall l \in TEP \quad (2.2)$$

where l are the expansion projects, w represents the with situation and wo represents the without situation of the expansion project considered; the value of the superscript ‘ TEP ’ represents that all the expansion projects included in the plan are installed (except the one being assessed), and the value ‘ \emptyset ’ for this superscript represents that none of these expansion projects are installed (except the one being assessed).

¹³ European Network of Transmission System Operators for Electricity.

¹⁴ The definition provided in (ENTSO-E 2013) says that the TOOT method “...consists of excluding grid element projects from the forecasted network structure on a one-by-one basis and to evaluate the load flows over the lines with and without the examined network reinforcement (a new line, a new substation, a new PST, ...)”.

¹⁵ The definition provided in (ENTSO-E 2013) says that the PINT method “...considers each new item grid element on the given network structure one-by-one and evaluates the network flows over the lines with and without the examined network reinforcement”.

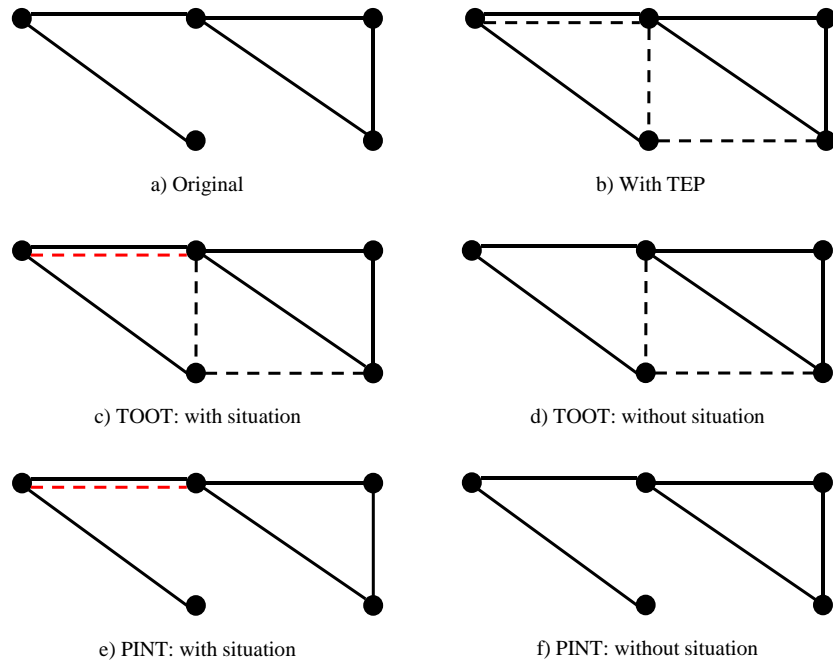

Fig. 2.1. Situations compared when using the TOOT and PINT methodologies. The original network, in a), is represented with continuous lines, while the expansion plan proposed, in b), is represented with dashed lines. The 'With' and 'Without' situations employed when using TOOT and PINT are represented in c)-f). The expansion project whose benefits are to be assessed is indicated in red.

Illustrative example

A stylized 3-bus power system (employed only for didactic purposes) will be used to illustrate the TOOT and PINT methodologies. This example will be used through the whole chapter.

The power system represented in Fig. 2.2 has three nodes (A, B and C) originally isolated. The TEP (expansion plan) includes lines AB1, AB2 and AC connecting them. Their features (all the line have the same features) are depicted in Fig. 2.2. For the sake of simplicity, we consider only one operation situation, representing the operation of the system over the 8,760 hours of the year in the target operation horizon. The overall benefits produced by the plan amount to €258M/year, which correspond to the same reduction in the operational costs achieved by producing all the power needed with the units located in nodes B and C instead of the units located in node A.

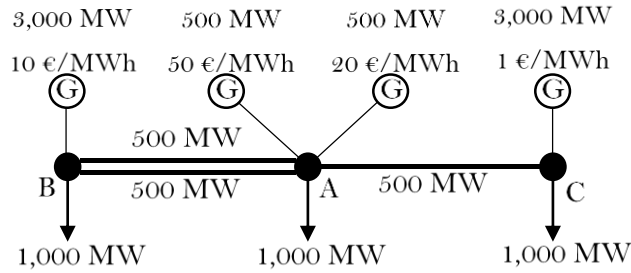

Fig. 2.2. 3-bus power system schematic representation.

We consider that lines AB1 and AB2 are one single project (called Project AB) and line AC is another project (Project AC). The operational costs of the system for the different situations considered when applying PINT and TOOT are displayed in Table 2.1.

Table 2.1. Operational costs [€/year] in the situations considered for the PINT and TOOT methodologies

Project	PINT		TOOT	
	With	Without	With	Without
AB	184	403	144.5	188
AC	188	403	144.5	184

Therefore, the benefits produced by each project, according to both methodologies, are computed using (2.1) and (2.2), and are shown in Table 2.2.

Table 2.2. Dispatch benefits [€/year] of the expansion projects computed using the PINT and TOOT methodologies

Project	PINT	TOOT
AB	$403-184=219$	$188-144.5=44$
AC	$403-188=214$	$184-144.5=39$
Total	433	83

ENTSO-E recommends to employ the TOOT methodology for the cost-benefit analysis of an expansion plan, like the TYNDP, while the PINT methodology is recommended for individual project assessments (ENTSO-E 2013). Anyhow, both TOOT and PINT methodologies have been employed by ENTSO-E for the assessment of the projects in the TYNDP (ENTSO-E 2014). Besides, in (Roustaei et al. 2014), the authors employ TOOT to evaluate the benefits provided by each of a set of previously defined projects. In (von der Fehr et al. 2013) and (Mezosi & Szabo 2014), the authors recommend that benefits of projects be estimated both using the PINT and TOOT methodologies. Then, if the benefits estimated with both methodologies differ significantly, the authorities should carry out further analyses to obtain a reliable estimate of these benefits¹⁶.

2.2.3 Shapley Value

More elaborate, or complex, approaches have also been proposed to estimate the benefits of expansion projects. Works in (Hasan et al. 2014) and (Contreras et al. 2009) involve the application of the Shapley approach for the allocation of the benefits of an expansion plan, or group of projects, to the projects comprising this plan, or group. In (Hasan et al. 2014), the authors determine the benefits of four transmission projects in Australia using the Shapley value. In (Contreras et al. 2009), the Shapley value is used to compute the incentives, or remuneration, that should be provided to transmission investors¹⁷.

The Shapley value¹⁸ is a cooperative game theory solution concept that results in a unique allocation to the individual players of the total benefit produced by the cooperation (or coalition) of all the players in the game. It assigns to each player his “average marginal contribution” in the game to the global benefit, rather than being based on strategic considerations. It can be calculated according to (2.3).

$$\phi_i(v) = \sum_{S \subseteq N: i \notin S} \frac{|S|!(n-|S|-1)!}{n!} (v(S \cup \{i\}) - v(S)) \quad (2.3)$$

¹⁶ Besides, authors in (Mezosi & Szabo 2014) acknowledge that, “*if the timing of construction of the interconnectors were according to schedule, the analysis could be carried out based on the construction order, ...*”. This point is further discussed in Section 2.3.

¹⁷ Notice that changing the set of projects to be undertaken would automatically result in a change in the benefits produced by each project, which could potentially lead to a network expansion that departs from the most efficient one.

¹⁸ The Shapley value receives its name in honor of Lloyd Shapley, who introduced it in 1953. More details about the Shapley value may be found in (Winter 2002; Roth 1988).

where ϕ_i is the Shapley value, $v(\cdot)$ is the benefits function, N is the set of players (or grand coalition or the coalition of all players), n is the number of players and S is a coalition of players¹⁹. An equivalent formula for the Shapley value is indicated in (2.4).

$$\phi_i(v) = \frac{1}{n!} \sum_R [v(P_i^R \cup \{i\}) - v(P_i^R)] \quad (2.4)$$

where the sum ranges over all $n!$ orders of the players is R and P_i^R is the set of players in N which precede i in the order R .

According to this approach, the benefits created by each expansion project are estimated as the average incremental benefit resulting from its deployment over all the possible orderings of deployment of projects in the plan.

Illustrative example

The Shapley methodology is illustrated here using the same example as before. In order to compute the Shapley value of an expansion project, all the possible orders of deployment of projects included in the expansion plan are considered. In this case, we have two possible orders:

1. Project AB is deployed first and Project AC is deployed second.
2. Project AC is deployed first and Project AB is deployed second.

The incremental benefits produced by each expansion project when they are deployed in the different orders are indicated in Table 2.3. Finally, the benefits produced by each project, according to their Shapley value, are the average of the incremental benefits in the different orders, and are indicated in the last column of Table 2.3²⁰.

¹⁹ This formula can be interpreted as follows: imagine that the coalition considered is only composed by one player each time, and that each player demands its contribution to the total benefit of the whole $v(S \cup \{i\}) - v(S)$ as its compensation. Then, the compensation for each player is computed as the average contribution of this player over the possible different permutations in which the coalition can be formed.

²⁰ Note that, as displayed in Table 2.3, the estimated benefits of the expansion project AB using the Shapley method (the Shapley value of this project) amount to 131€M/yr. The incremental benefits produced by project AB when it is the first one deployed (i.e. project AC is deployed in the second place) amount to 219€M/yr; while the incremental benefits produced by project AB when it is the second one deployed (i.e. project AC is deployed first) amount to 44€M/yr. Therefore, the Shapley value of project AB, which is computed as the average of 219€M/yr and 44€M/yr, amounts, indeed, to 131€M/yr. However, one should note that, for none of these two possible orders of deployment of projects, shall project AB produce an incremental benefit of 131€M/yr (neither when it is deployed first, nor when it is deployed second). Hence, assigning to an expansion project a benefit that is equal to its Shapley value involves assuming that the

Table 2.3. Dispatch benefits [€M/year] of the expansion projects computed using the Shapley methodology

Project	Incremental benefits		Benefits
	First order	Second order	
AB	219	44	$(219+44)/2=131$
AC	40	215	$(40+215)/2=127$
Total	258	258	258

2.3 CHARACTERISTICS REQUIRED FOR A METHODOLOGY TO DETERMINE THE BENEFITS AND BENEFICIARIES OF TRANSMISSION EXPANSION PROJECTS AND CRITICAL REVIEW OF EXISTING METHODOLOGIES

Benefits produced by expansion projects within a plan drive the design of this plan, i.e. the selection of which projects to undertake. Thus, any methodology to estimate the benefits and beneficiaries produced by expansion projects must be consistent with the technical and economic principles ruling the expansion of the network. Bearing this in mind, this section discusses the characteristics that the process of assigning benefits to projects in a plan should have. In addition, the existing methodologies are assessed in the light of these properties.

The characteristics required for a methodology are listed as follows:

- 1) Benefits should take into account interactions among expansion projects.
- 2) Benefits should not depend on the order of deployment of projects in the plan (or assume a specific order).

benefits created by this project differ from the incremental ones that would, in any case, result from the deployment of this project in real-life. This is why the Shapley value of an expansion project can be considered an artificial construct, as was mentioned in section 3.2.2 of Chapter 3 (see footnote 40).

- 3) Benefits assigned to projects are a function of the changes these, and other projects in the plan, produce in the network, and not of how the investments are clustered into projects.
- 4) The benefit assessment methodology should be applicable to real-life systems and large expansion plans.
- 5) The benefit assessment methodology should be easy to understand.

2.3.1 Benefits should take into account interactions among expansion projects

Benefits assigned to expansion projects aim to reflect the impact that they would have on the SW. However, the impact that a single project has on the system –the benefits– is clearly dependent on other projects undertaken together with the concerned one. On one hand, there are some projects that must be deployed together in order to realize some benefits (complementary projects). On the other hand, there are some other benefits that can be produced by any of several possible projects to deploy (alternative projects, in this regard). Then, if one of these later projects is considered already in place, implementing afterwards a second project within this group would not produce any benefits of the type considered (these benefits will be obtained even if this second project is not undertaken).

Consequently, almost every project in an expansion plan is somehow related to others in this plan. Hence, any CBA of expansion projects carried out on an individual basis, i.e. for each project in isolation, should be deemed inappropriate. Assessing the benefits of projects as part of an expansion plan implies taking into account the interactions occurring among these projects. Ignoring these interactions may lead authorities to underestimate, or overestimate, the effects of expansion projects on system operation and, therefore, their benefits. This would lead to an error in the computation of the benefits and beneficiaries obtained from expansion projects. Thus, the benefits of each project in the expansion plan should be assessed jointly with those of the rest of projects²¹.

²¹ For example, the Desertec Initiative was aimed at connecting the north of Africa and the Middle East with Europe in order to consume in the latter region part of the energy produced in the two former ones (Desertec Initiative (Desertec Foundation 2009)). This requires both interconnecting the north of Africa and the Middle East (MENA region) with the European continental network and reinforcing the existing network in Europe. Interconnection projects (the first type ones) and projects strengthening the grid within Europe (second type) are complementary. This means that the amount of benefits produced by interconnection projects between Europe and the MENA regions is dependent on the deployment of those projects strengthening (meshing) the European grid and vice versa. Thus, only interconnecting Europe and the MENA region would still provide some benefits, but the benefits produced would be significantly larger if the network within Europe is also reinforced, which could result in a larger amount of electricity produced in the MENA region being consumed in Europe and the electricity produced by offshore wind generation in

Note that the PINT methodology overestimates the benefits that can be produced by any of several projects (benefits produced by alternative projects), and underestimates those benefits only realized when several projects are all undertaken (benefits produced by complementary projects). On the other hand, TOOT underestimates the benefits that can be produced by any of several projects, while it overestimates the benefits produced by complementary projects. This problem was already indicated by the authors in (von der Fehr et al. 2013), as mentioned previously. Given that Shapley methodology considers all possible deployment orders of projects, it is able to take into account the interactions occurring among projects. Hence, this methodology is distributing both, benefits rendered by any of several projects, and benefits that are contingent on the deployment of several other projects, among all those projects that contribute to these benefits.

Illustrative example

Table 2.4 summarizes the benefits of expansion projects calculated previously accordingly to the PINT, TOOT and Shapley (see Table 2.2 and Table 2.3). As can be seen, each project's benefits largely depend on the methodology applied. Note that only Shapley provides project benefits that add up to the total benefits actually produced by the whole plan (€258M/year). In contrast, PINT and TOOT provide extreme values. These extreme values are a consequence of PINT and TOOT being unable to take into account all interactions taking place among the two projects.

Table 2.4. dispatch benefits [€M/year] of the expansion projects computed using the different approaches reviewed

Project	PINT	TOOT	Shapley
AB	219	44	131
AC	214	39	127
Total	433	83	258

In this case, PINT overestimates the benefits provided by projects, while TOOT underestimates them, because neither TOOT nor PINT takes into account the fact that part of the benefits produced by the TEP are not exclusive of a specific project,

the North Sea complementing imports from the Middle East and Africa in making the renewable electricity supply into Europe more stable and reliable.

but can instead be provided by several projects²². This is the case here, because projects AB and AC are alternative projects helping to replace the expensive energy produced by the generator located in node A with the cheaper energy produced by generation units located in nodes B and C.

2.3.2 Benefits should not depend on the order of deployment of projects in the plan (or assume a specific order)

Computing the benefits produced by projects when they are deployed in a certain order is simple. Determining the benefits created by each project as the change in the SW brought by this project with respect to the situation when the project is not implemented also seems intuitively correct. However, projects within a plan are decided at the planning stage jointly, not considering a specific order of deployment²³. In fact, expansion projects remain in operation and producing benefits for the system and its users over a long period of time (for example, Spain recognizes a 40-year life cycle for regulated network investments²⁴). Thus, the benefits that drive the decision to undertake these expansion projects are not the result of considering a certain order of deployment of these projects. As a consequence, the computation of benefits from them should not consider a specific order, even if the order considered is the one eventually implemented²⁵.

Considering a specific order is an arbitrary decision because, in most cases, the final deployment order in which projects are actually deployed depends on a variety of non-controllable circumstances that are not related with the intrinsic value –benefits– of the

²² An extreme problem of not fulfilling this characteristic was also detected in TYNDP for Security of Supply (SoS) benefits. As recognized by ENTSO-E, “*The TYNDP methodology fails to capture the benefits of projects regarding Security of supply*” (ENTSO-E 2014). ENTSO-E also states that, “*by nature, the TOOT method, which consists of measuring the marginal benefit of a project, also limits any energy not supplied in the valuation*”. This is so because “*... the benefit of each interconnection is assessed separately assuming all others already been commissioned, its marginal benefit with respect to ensuring the power supply is zero*”. The reader is referred to footnote 30 in this chapter to see the situation just described in the illustrative example presented through this section.

²³ In the TYNDP 2014 (ENTSO-E 2014), for example, the Baza project (ID-13), the RES in Alentejo project (ID-85), the Celtic Interconnector project (ID-107) and the Lake Geneva South project (ID-199) are all scheduled to be commissioned in 2025.

²⁴ Royal Decree 1047/2013.

²⁵ Only projects undertaken in the same time frame are considered. It does not make sense to make this assumption for projects that are going to be carried out in different time horizons.

projects. For example, public opposition to the deployment of a project, administrative delays in the permitting process, lack of funds for the construction of the project, or the lack of agreement on the allocation of the costs of the new projects, may delay the deployment of expansion projects, regardless of the value it has for the system²⁶.

Furthermore, considering a specific order (there are as many possible orders of deployment of these projects as permutations of them) implies not being able to capture all the interactions occurring among expansion projects. Hence, the benefits that each individual user is obtaining from each project, and the whole plan, computed according to some methods may not be coherent with those actually obtained by each user from this project, or the plan, when the whole expansion plan is implemented.

Actually, computing a ranking of projects according to their benefits should affect the order of deployment of these projects so as to ensure –or facilitate– the deployment of the most important ones. Then, it would not make sense that arbitrarily choosing a specific project deployment order conditions the benefit assigned to each project.

It can be concluded, therefore, that the estimation of the benefits of each project included in an expansion plan cannot be made considering a specific order of deployment of projects.

Note that some of the methodologies to compute the benefits of expansion projects discussed above implicitly assume a certain order for the deployment of these projects. Thus, when assessing the benefits of each project, the TOOT methodology assumes that the project assessed is the last one deployed, while the PINT methodology assumes that each project is the first one deployed. On the contrary, benefits assigned by the Shapley value do not result from assuming any specific order (all possible deployment orders are considered), as required.

Illustrative example

In the analysis of project AB, PINT considers that it is the first one to be deployed, while the TOOT considers that it is the last one to be deployed. Similarly, the analysis of project AC using the PINT methodology considers that it is the first project deployed, while the TOOT considers that it is the last one deployed. Shapley

²⁶ For example, about 53% of the projects included in the pan-EU significance projects of the CSW (Continental South-West) region in the TYNDP 2012 are delayed, rescheduled or cancelled for a variety of reasons (ENTSO-E 2014).

however, assumes no specific order.

2.3.3 Benefits assigned to projects are a function of the changes these, and other projects in the plan, produce in the network, and not of how the investments are clustered into projects

As previously mentioned, when planning the expansion of the grid, the expansion projects to undertake are chosen according to their costs and benefits (increase in the SW). Given a certain expansion plan to be fully deployed, and assuming that all new transmission assets built as part of the plan are available, the increase in the SW caused by any group of projects within an expansion plan is a function of the changes in the operation of the system caused by: 1) the changes to the corridors in the network (increases in the capacity and/or admittance of these corridors) resulting from these projects; and 2) the additional changes to corridors resulting from the deployment of the remaining projects in the expansion plan. Then, the total benefits caused by this group of projects do not depend on which specific projects the network investments (reinforcements of existing assets or new ones) within this group are divided into, nor on which projects the rest of the expansion plan is divided into.

Note that neither TOOT, PINT nor Shapley produce results that comply with this property: PINT overestimates the benefits that can be produced by any of several (alternative) projects, and underestimates those produced by complementary projects. On the other hand, TOOT underestimates the benefits that can be produced by any of several (alternative) projects, while it overestimates the benefits produced by complementary projects. Benefits assigned by Shapley to a subset of the reinforcements in the expansion plan depend on the features (number and size) of the projects these reinforcements are clustered into, as well as the features of the projects that the rest of reinforcements in the plan are clustered into. Therefore, none of the currently existing methods analyzed features this property. There are several implications of a benefit allocation method featuring this property:

- a) *Benefits assigned to projects should add up to the total benefits of the plan or group of projects considered. In other words, the project benefit function should be additive*

The benefits assigned to the individual projects of a group of them belonging to the expansion plan should add up to the benefits that would be assigned to this group as a whole if considered as a single project. In other words, the function 'f' of the benefits caused by projects within a certain expansion plan should be additive, i.e. for any two projects x and y of the plan, $f(x+y)=f(x)+f(y)$. Note that the estimated benefits of

individual projects, or groups of them, may change when the whole set of investments to be undertaken (the expansion plan) changes. However, given an expansion plan, it can be stated that the benefits produced by the overall set of investments comprising it, or by any subset of investments within this plan, does not depend on the set of projects into which the plan is divided. This is illustrated below with the help of an example.

Let us assume that, as a result of the implementation of an expansion plan, two nodes A and B get connected through two identical lines (circuits). These two lines may be built as part of the same project. Alternatively, it is also possible to consider each line as an independent project²⁷. As mentioned above, the benefits produced by each project are a direct consequence of the changes to the network –and later, to the system’s operation– resulting from the deployment of this project, and of the others in the plan. Therefore, considering one or two projects for the connection of these two nodes does not affect the operation of the power system. Thus, the benefits assigned to the deployment of both lines should add up to the same amount in both situations (either when they are considered one or two projects). In both situations, the effects on system operation of the construction of the two circuits are the same.

Illustrative example

Please note that only Shapley provides project’s benefits that add up to the total benefits actually produced by the whole plan (€258M/year). In contrast, as already mentioned, PINT and TOOT provide extreme values (see Table 2.2 or Table 2.4), i.e. the total benefits computed with PINT and TOOT do not add up to the total benefits of the expansion plan.

- b) *Benefits assigned to each project should be independent of the rest of projects that the plan is divided into*

Benefits assigned to a project within a plan should not depend on the set of projects into which the rest of investments within the plan are grouped, since this is certainly not related to the value that investments within the former project have for the system –and for the network users– in the context of the expansion plan. In the previous example, benefits assigned to the rest of projects in the plan should not depend on whether the two

²⁷ Imagine that each line, or project, is proposed by different investors and each line does not need the other line to be installed.

new circuits linking nodes A and B are considered a single project or two separate ones. The fact that considering one project or two may change the benefits estimated –and then the ranking– of projects, or the beneficiaries of these projects is not a desirable characteristic. This may encourage some network promoters to subdivide projects into others, or merge them, in order to obtain an estimation of the benefits produced by their projects that is more favorable for them (larger benefits assigned to these projects) –and then a higher ranking for these projects–. They may also alter the definition of projects to affect the computation of the benefits that each user obtain from these projects and therefore the allocation of their cost²⁸.

Illustrative example

Let us now consider a different set of projects within the TEP. Instead of considering that lines AB1 and AB2 are a single project, we consider each line to be a separate project (for example, because they are proposed by different agents). The benefits of each project, according to the different methods considered, are provided in Table 2.5. Note that the characteristics of the plan (and in particular of the investments affecting corridor A-B) are the same as before.

Table 2.5. Dispatch benefits [€M/year] of the expansion projects computed using the different approaches reviewed

Project	PINT	TOOT	Shapley
AB1	175	0	73
AB2	175	0	73
AC	214	39	112
Total	565	39	258

Comparing Table 2.4 and Table 2.5, it can be seen that the benefits assigned to project AC using the Shapley approach change (from €127M/yr. to €112M/yr.) when

²⁸ Having the benefits and beneficiaries of projects affected by their definition may encourage project promoters (or countries in a multinational system) to group network investments into projects in order to obtain a more favorable allocation of the cost of these projects (a promoter could prefer to recover the costs from users that are considered more reliable), assuming that the allocation of the cost of expansion projects is driven by benefits allocated to each user.

lines AB1 and AB2 built are considered separate projects with respect to the situation where both lines are considered within the same project (see section 2.3.1).

- c) *The benefits assigned to any elemental project, or investment, shall not depend on the size of the project it belongs to: comparability or isonomy requirement*

Expansion projects can be deemed to be comprised of a multiplicity of elemental projects of the unit size defined. According to the arguments just provided, the benefit assigned to each elemental project should not depend on the size of the overall project to which this elemental one belongs. This means that benefits assigned to projects should comply with the comparability or isonomy requirement. In the previous example, the benefit assigned to an elemental increase in the size of a circuit linking nodes A and B (both in terms of capacity and admittance) should not depend on whether each new circuit linking A and B is a separate project, or both circuits are the same project.

Illustrative example

When considering the alternative definition of projects just mentioned, where lines AB1 and AB2 are separate projects, the characteristics of the plan are the same as originally, where both circuits were considered a single project. Therefore, the changes in the network and operation of the power system caused by projects AB1 and AB2 as a whole are also the same, as well as the total benefits of the plan. Hence, the sum of the benefits assigned to projects AB1 and AB2 should be the same as the benefits assigned to the original project, AB. This would also mean that an elemental project comprising projects AB1 or AB2 has the same value as an elemental project comprising project AB (which has twice as many elemental projects as either project AB1 or project AB2).

Nonetheless, the results show that the overall benefits of projects AB1 and AB2 computed in any of the considered methodologies are different from those computed previously for project AB²⁹. This result also implies that, according to these methodologies, the elemental projects comprising AB1 or AB2 are assigned a different benefit from the one assigned to elemental projects of the project AB considered as a single one. For instance, the application of the TOOT approach

²⁹ Note that this result is also related to implication a) previously described.

results in zero benefits being assigned to elemental projects comprising projects AB1 and AB2³⁰ while these elemental projects are assigned a positive benefit when they are considered part of a single project (project AB).

2.3.4 The benefit assessment methodology should be applicable to real-life systems and large expansion plans

Reinforcing the network expansion has traditionally involved undertaking a large number of projects. Moreover, transmission expansion planning is undergoing a process of coordination at regional level. Hence, the number of projects within expansion plans has grown (and is expected to grow even more) as transmission expansion planning is coordinated over larger regions. For instance, the new Ten Year Network Development Plan 2016 (TYNDP 2016) (ENTSO-E 2016) jointly developed in Europe by ENTSO-E and ACER foresees 200 expansion projects. Therefore, the benefit allocation methodology employed should be able to cope with large expansion plans.

Note that both the PINT and TOOT methodologies are simple to apply. On the other hand, due to its combinatorial nature, the Shapley methodology is, computationally speaking, very demanding. The size of the problem to solve under Shapley increases fast with the number of projects in the expansion plan (the number of permutations to consider all the deployment orders with N projects is N!). Thus, application of the Shapley methodology to real systems would be very challenging, if not impossible³¹.

Illustrative example

The application of the Shapley value, when projects AB and AC are considered, involves considering two deployment orders (2!): one where project AB is deployed first and another one where project AC is deployed in the first place. However, if

³⁰ Note that, in this case, benefits estimated for projects AB1 and AB2 using TOOT are zero. This is an extreme case that shows the consequences of the inability of this methodology to take into account interactions among projects. Projects AB1 and AB2 are alternative projects performing the same function and thus, TOOT is underestimating the benefits of each project. This situation is similar to the one happening in the TYNDP and mentioned in footnote 22.

³¹ Given that the TYNDP 2016 foresees 200 expansion projects in transmission and storage, the application of the Shapley methodology to compute the value of these projects would require to consider 200! deployment orders (more than 10^{374}). This is not affordable.

projects AB1, AB2 and AC are considered, the number of deployment orders increases to six (3!):

- 1) AB1 first, AB2 second and AC third.
- 2) AB1 first, AC second and AB2 third.
- 3) AB2 first, AB1 second and AC third.
- 4) AB2 first, AC second and AB1 third.
- 5) AC first, AB2 second and AB1 third.
- 6) AC first, AB1 second and AB2 third.

2.3.5 The benefit assessment methodology should be easy to understand

The methodologies analyzed are to be used by regulatory and planning authorities, part of whose personnel may not be knowledgeable about the technical functioning of the system. Moreover, the uncertainty about the result of the assessment process of expansion projects and a possible delay –or excessive duration– of this process may decrease the value that the proposed expansion projects have for the system (or for the private investors proposing them). Therefore, it is relevant that the benefit allocation method is as simple as possible in order to facilitate its understanding and to avoid possible future complaints and reduce the uncertainty faced by network developers and market parties in the system about the benefits to be assigned to the projects promoted by the former and the fraction of the cost of new lines to be paid by the latter (see (Saphores et al. 2004) for a discussion about this issue).

Due to its simplicity, both PINT and TOOT are very easy to understand. The Shapley value is more complex, but it is an intuitive approach and a recognized method for the allocation of costs and benefits in other disciplines.

2.4 CONCLUSIONS

As acknowledged by recent regulations enacted in the EU and USA, estimating correctly the benefits produced by individual expansion projects within an expansion plan, or group of projects, is an important task. However, until now, the computation of the fraction of the **benefits** of the whole expansion plan, or group of projects, that can be **attributed to** each one of the individual **expansion projects** that comprise the plan **remains largely unexplored**.

This chapter has reviewed the main methodologies employed for this purpose. Additionally, this chapter includes a detailed discussion of the main characteristics that should be featured by a methodology for it to determine correctly the benefits produced by expansion projects comprised in a plan and correctly determine their beneficiaries. Existing methodologies have then been analyzed in the light of these characteristics, showing the main drawbacks they have.

The review of existing methodologies and its analysis based on the characteristics discussed are illustrated with a very small case example. It can be realized that, **even in this small case, where only three new transmission investments are considered and uncertainty is not taken into account, none of the existing methodologies features most of the characteristics described.**

A summary of how the existing methodologies perform according to the properties just described is provided in Table 2.6.

Table 2.6. Main characteristics of the benefit assessment methodologies considered

Characteristic	TOOT	PINT	Shapley
Benefits of projects take interactions into account	No	No	Yes
Benefits of projects do not depend on their order of deployment	No	No	Yes
Benefits of investments do not depend on the projects they belong to	No	No	No
The methodology is applicable to real-life systems and large expansion plans	Yes	Yes	No
The methodology is easy to understand	Yes	Yes	Yes

Chapter 3

Methodology for benefit analysis

The previous chapter reviews the main methodologies that have been proposed to determine the benefits of expansion projects, within an expansion plan, and to identify the individual users benefitting from these projects. Moreover, a series of characteristics that should be featured by any methodology were discussed, and the methodologies are compared with respect to these characteristics. None of the methodologies reviewed features all of these characteristics.

In this chapter, the method proposed to determine the allocation of the benefits, and the beneficiaries, produced by an expansion plan, or group of projects, to the individual projects comprising this plan (or group) is described. I then describe the specific application of this method to estimate the economic benefits produced by expansion projects and to determine the individual users benefitting from these projects. Moreover, I also discuss its application to calculate the contribution of expansion projects to other type of benefits produced in the dispatch. Finally, the methodology proposed is evaluated in the light of the characteristics described in Chapter 2.

3.1 INTRODUCTION

Cooperative game theory is a very important area within game theory. It deals with the problem of allocating the joint benefits –or costs– produced by the cooperation of several players, or to decide if these players would finally collaborate (form coalitions) in order to produce these benefits –or incur these costs. The characteristic function is the function to be allocated to the players that are collaborating. It describes how much benefit the set of players collaborating in a coalition would obtain (or cost would incur). It has been applied in several –energy or not energy– fields. For instance, it has been applied for proposing solutions for bankruptcy situations (Alonso-Meijide & Carreras 2011), or to analyze voting coalitions (Alonso-Meijide & Carreras 2011). The previous chapter showed the lack of a suitable method to determine the benefits produced by the individual projects that an expansion plan comprises. Cooperative game theory seems to be a promising option in order to be applied for this purpose. In fact, in the power sector, the Shapley³² and Nucleolus³³ solution concepts have been widely applied. For example, the Shapley value has been proposed to allocate the cost of transmission networks of electricity to the network users (Hasan et al. 2014; Stamtsis & Erlich 2004; Zolezzi & Rudnick 2002; Tan & Lie 2002; Tsukamoto & Iyoda 1996), allocate the profits obtained from wind-hydro coordination among the producers coordinating their production (Zima-Bočkarjova et al. 2010), allocate the fixed start-up costs of generation units among loads (Hu Zhaoyang et al. 2006), optimally allocate the resources shared (together with agent-based techniques) in smart grids and allocate the joint benefits obtained for their cooperation among the resources in the smart grid (Nguyen et al. 2013), allocate emission reductions achieved among the regions contributing to them (Chang et al. 2016), and allocate the profits obtained by a Virtual Power Plant (VPP) to the DER assets that comprise the VPP (Dabbagh & Sheikh-El-Eslami 2015). The Nucleolus method has been employed, for instance, also to solve the network cost allocation problem (Stamtsis & Erlich 2004; Zolezzi & Rudnick 2002; Tsukamoto & Iyoda 1996), allocate the fixed start-up costs of generation units among loads (Hu Zhaoyang et al. 2006), allocate the joint benefits of a RES portfolio (to reduce the risk) formed by assets belonging to different companies among these assets (Freire et al. 2015), and allocate the profits of a VPP to the DER in this VPP (Dabbagh & Sheikh-El-Eslami 2015).

³² As explained in Chapter 2, the Shapley value assigns to each player his average marginal contribution in the game to the global benefit (or to the global costs).

³³ The idea behind the Nucleolus solution concept is to assign to each player a payoff that makes the largest dissatisfaction (with the payoffs assigned) as small as possible.

The Aumann-Shapley approach (AS) is a generalization of the Shapley value that overcomes the latter's disadvantages³⁴ (Young 1994). This approach –or methods based on it– has also been widely used in several fields. For example, it has been applied to the allocation of telephone costs (Billera et al. 1978) to users, CO₂ emissions of a refinery to the products of the former (Pierru 2007), costs of waterworks to distribution or production services (Bogetoft et al. 2016), firm-energy rights to hydro plants (Faria et al. 2009), and electricity losses (Molina et al. 2010), congestion costs (Bakirtzis 2001; Wu et al. 2004; Yang & Xiao 2012), and reactive costs (Frias et al. 2008; Lin et al. 2006) to network users. It has also been employed in the transportation field (Samet et al. 1984), as well as to determine the use of the transmission network by each user. In the latter context, players in the game are the network users (generators and demands). Based on these results, AS can also be applied to the allocation of the fixed costs of existing electricity and gas transmission networks³⁵ (Junqueira et al. 2007; Zolezzi & Rudnick 2002; Morais & Marangon Lima 2007; Molina et al. 2013; Hadush et al. 2011) and for the determination of the inter-TSO compensations between countries in Europe (Dietrich et al. 2008)³⁶. A summary of the applications of the AS approach in the power sector is displayed in Table 3.1.

Table 3.1. Applications of the Aumann-Shapley approach in the power sector

Reference	Application	Characteristic Function	Players
(Bakirtzis 2001)	Allocate the increase in the costs required to relieve a congestion	Congestion cost	Loads
(Lin et al. 2005)	Reactive ancillary services cost allocation	Reactive cost	Loads
(Frias et al. 2008)	Allocate VAR capacity market costs	VAR suppliers and system operation costs	Loads
(Molina et al. 2010)	Allocate active and reactive losses	Losses (dependent of current)	Generators/loads

³⁴ As explained in Chapter 2, one of the biggest disadvantages of the Shapley value is that it is, computationally speaking, very difficult (or even impossible) to apply to real power systems. The other problem refers to the lack of isonomy: benefits assigned to players depend on how these players are aggregated.

³⁵ Please note that when AS is applied in this context, the shares of the fixed costs to be paid by generators, on the one hand, and demands, on the other, has to be determined ex-ante.

³⁶ More information about the application of AS to pricing can be found in (Roth 1988).

(Morais & Marangon Lima 2007)	Cost allocation of gas and electricity transmission networks	System operation costs	Generators/loads
(Junqueira et al. 2007)	Cost allocation of transmission network	Power flows multiplied by costs	Generators/loads
(Dietrich et al. 2008)	Inter-TSO compensation	Power flows multiplied by length of lines	Generators/loads
(Hadush et al. 2011)	Cost allocation of the transmission network: new and existing assets	Power flows multiplied by network cost	Generators/loads
(Molina et al. 2013)	Cost allocation of the transmission network	Power flows	Generators/loads

In this chapter, a method to determine the allocation of the benefits (economic and of other types) and beneficiaries among the projects within an expansion plan, or group of projects, is proposed. The following sections provide a description of the method proposed and demonstrate that it complies with the requirements described in the previous chapter.

3.2 METHODOLOGICAL FRAMEWORK TO DETERMINE THE BENEFITS AND BENEFICIARIES OF TRANSMISSION EXPANSION PROJECTS

This section explains the main concepts upon which the method proposed to determine the benefits of expansion projects within a plan is based. This method is described with more detail in the following sections.

3.2.1 Overview of the method

Computing the benefits produced by each project of an expansion plan and identifying their beneficiaries involves determining which of the benefits –positive or negative– obtained by the system (or the individual network users in a more disaggregated context) and provided by the plan, or group, can be allocated to each expansion project. This thesis proposes to make this allocation based on the AS concept (Aumann & Shapley 1974). Aumann-Shapley is a generalization of the Shapley value that “splits” original players in the Shapley cooperative game into “smaller” sub-players of a common size (hereafter called elemental players). Then, the contribution of these sub-players to the common goal is computed as the average incremental value that each one of them produces taking into account all the possible orders of introduction of these sub-players in the game. In our case, I am proposing to consider expansion projects as the players of the AS game. Therefore, expansion projects are divided into “smaller” elemental projects of –

theoretically— infinitesimal size. Then, the average incremental benefit obtained by the system (or the network users) thanks to an elemental project is determined as its value in the AS game³⁷. Finally, the benefits produced by an expansion project (a discrete one) are determined by aggregating the AS value of the elemental projects comprising this project.

In principle, the number of permutations when considering elemental projects considerably increases, becoming a combinatorial problem much larger than the computation of the Shapley value³⁸. Nonetheless, the AS method can be analytically solved: thanks to splitting expansion projects into infinite elemental projects —of infinitesimal size— (Aumann & Shapley 1974; Curien 2003), and using the properties of the hypergeometric probability distribution and the law of large numbers, it can be proved that the limiting process of agent splitting and permutation of the agent entrance order leads to the same solution as the AS allocation method (Aumann & Shapley 1974; Junqueira et al. 2007).

If $f(S)$ is a continuously differentiable benefit function and $f(\lambda S)$ is the benefit calculated for a fraction of the size of expansion project $ep(\lambda S)$, where $\lambda \in [0,1]$, the benefit provided by each expansion project ep can be analytically computed using (3.1).

$$B_{ep} = S_{ep} \cdot \int_0^1 \frac{\partial f(\lambda S)}{\partial S_{ep}} d\lambda \quad (3.1)$$

where λ is the integration factor and S_{ep} is the size of the expansion project ep . Note that the term inside the integral is the marginal benefit provided by a project with a size of λS . In fact, it is also the benefit of adding an elemental project to a project of size λS . Hence, the per unit benefit of projects computed using the AS approach (benefits produced by projects per unit of size of these projects) corresponds to the average of the marginal benefits of these projects with respect to their size when this size increases homothetically for all these projects from zero to their total size. Hence, the total benefit produced by a project according to AS can also be interpreted as the average benefit provided by an elemental project belonging to the aforementioned project multiplied by the size of this same project; or as the sum of the average benefits of all the elemental projects comprising this project. Please, note also that the integral in (3.1) implies a continuous increase of λ in

³⁷ The average incremental benefit obtained by the system (or the users) from an elemental project is the average difference in the system's (this user's) benefits resulting from the deployment of this elemental project when all the elemental projects are successively deployed and all the permutations of the deployment order of elemental projects are considered.

³⁸ Remember that, due to its combinatorial nature, the size of the Shapley value problem increases exponentially with the number of players being considered. Thus, the method becomes computationally unfeasible for large problems.

the interval $[0,1]$. This continuous increase simulates, or represents, the gradual deployment of the expansion plan –or the projects within it–. This integral (3.1) can be numerically calculated by discretizing the variable λ in K values in the interval $[0,1]$, if K is sufficiently large. Of course, the accuracy of this numerical integration process is directly related to the number of steps K taken.

3.2.2 Considering expansion projects as players of the Aumann-Shapley game

As previously mentioned, the approach here proposed differs from previous AS approaches in the fact that I consider that the players of the AS game are the expansion projects being assessed. This way, I am able to assign to expansion projects the benefits being evaluated. Note that the usual approach (network users as players of the game³⁹), evaluates the effects that users (generators and loads) have on the use of the lines of the power system. Then, the identity of the users causing network investments is inferred by analyzing these effects.

It is important to remark that splitting the expansion projects into elemental ones does not mean that I consider that network investments can be physically divided into these elemental projects, i.e. that they are continuous. Expansion projects are discrete and therefore, their benefits and beneficiaries to consider when planning the expansion of the network are also discrete.

However, once the set of investments to be undertaken within the expansion plan has been defined, the computation of the value of each investment or the benefits that each user obtains from each expansion project, or reinforcement within it, should only depend on the overall reinforcements made to the network within the expansion plan, or overall increase in the size of each network asset affected by the expansion plan, and on the set of network users in the system and their profile. Benefits assigned to expansion projects should never depend on how network investments are grouped into projects. Splitting discrete projects –therefore using elemental ones instead of them– can be considered an artifact employed to determine the contribution of each expansion project to the benefits obtained by the system and its users (generation, demand, or transmission owner) from the plan per unit of size of this expansion project. Based on the per unit benefit obtained, one can compute the benefits and beneficiaries of expansion projects while complying with the properties discussed at length in Chapter 2.

The reader should note that the Shapley value of a project in the expansion plan is also an artificial construct. The estimated benefits and beneficiaries obtained for each project

³⁹ Please, see Table 3.1 to have examples of the players normally considered when using the AS approach.

when using this approach (average ones over all orders of deployment of expansion projects) are not obtained in reality under any possible order of implementation of the projects⁴⁰.

3.2.3 Mathematical formulation of the economic dispatch problem

The benefits produced by an expansion plan correspond to the increase in SW this plan creates. The increase in SW caused by the whole plan can be computed by deducting the SW in the situation where the plan is not deployed from the SW corresponding to the situation where the plan is deployed⁴¹. Social Welfare is computed as the utility obtained by demand from energy consumed minus the cost of electricity supply. In this work, as far as the computation of results is concerned, only the reductions in operational costs, CO₂ emissions or energy not served (ENS)⁴² these projects create, are considered as dimensions of the increase in SW produced by network expansion projects.

Assuming that demand in the system is completely inelastic, the problem of maximizing the SW turns out to be equivalent to that of minimizing the costs in the energy dispatch (Pérez-Arriaga 2013). The SW should be computed for a set of operation situations (snapshots or time periods) that are representative of all those that may occur, and a set of scenarios on the evolution of the system that are representative of all those that may unfold over the economic life of the projects in the plan⁴³. However, for the sake of

⁴⁰ Please, see footnote 20 (in Chapter 2) for an example of the artificial construct of the Shapley value.

⁴¹ The increase in Social Welfare can be computed in this way if not undertaking the expansion projects within an expansion plan is a rational alternative to deploying this plan. If the rational alternative to deploying the plan were to undertake another set of reinforcements and/or modify the distribution of generation and demand within the system, the social welfare both with the expansion plan in place and in this second –alternative– situation would have to be computed to determine the overall benefits brought about by the plan. Benefits of the plan would, then, amount to the difference between the social welfare in the latter two situations.

⁴² Actually, other components of SW may be considered when computing the increase in SW, such as, for example, the environmental benefits or the reduction achieved in the cost of reserves (Chang et al. 2013). This work only considers these ones for simplicity reasons. However, extending the formulation applied here to other types of benefits is possible.

⁴³ Dealing with short- and long-term uncertainty in transmission expansion planning involves considering several operational situations and scenarios. An example of the consideration of scenario uncertainty in expansion planning is described by ENTSO-E in its TYNDP-2014 (ENTSO-E 2014), though other approaches are possible. In (ENTSO-E 2014), the CBA of projects is performed independently for future scenarios considered as possible. Due to the inherent uncertainty existing about the scenario to be eventually realized, the CBA results for each expansion project are presented as ranges (between the minimum and maximum values computed for any of the scenarios). More information on snapshot selection processes can be found in (Fitiwi et al. 2015; Ploussard et al. 2016).

simplicity, and in order to describe the method proposed easily, only one future scenario is considered in the problem formulation provided here. When considering several scenarios, the benefits obtained by users from projects should first be computed separately for each of them. Then, benefits computed for individual scenarios should be combined according to the objective pursued in the analysis. A possible formulation of the economic dispatch problem for each time period is presented in (3.2)–(3.7)⁴⁴.

$$\min OpCost_t = \min[\sum_g VC_g gp_{g,t} + CO2Cost \sum_g ECO2_g gp_{g,t} + \sum_c ENSCost \cdot ens_{c,t}] \quad (3.2)$$

subject to:

$$\sum_{g \in i} gp_{g,t} - \sum_{j \in l(ij)} f_{l(ij),t} + \sum_{c \in i} ens_{c,t} = \sum_{c \in i} D_{c,t} \quad \forall i, t \quad (3.3)$$

$$f_{l(ij),t} = (\theta_{i,t} - \theta_{j,t}) y_{l(ij)} \quad \forall l(ij) \in AC, t \quad (3.4)$$

$$-\overline{F_{l(ij)}} \leq f_{l(ij),t} \leq \overline{F_{l(ij)}} \quad \forall l(ij), t \quad (3.5)$$

$$0 \leq gp_{g,t} \leq \overline{GP_g} \quad \forall g, t \quad (3.6)$$

$$0 \leq ens_{c,t} \leq D_{c,t} \quad \forall c, t \quad (3.7)$$

where VC_g is the variable production cost of unit g ; $gp_{g,t}$ is the power production of unit g in time period t ; $CO2Cost$ is the per unit cost of CO_2 emissions; $ECO2_g$ is the CO_2 emission rate of unit g ; $ENSCost$ is the unit cost of ENS; $ens_{c,t}$ is the amount of energy demanded by a consumer c that is not served in time period t ; $D_{c,t}$ is the power consumption of consumer c in time period t ; $f_{l(ij),t}$ is the power flow through line l , which connects nodes i and j , in time period t ; $\theta_{i,t}, \theta_{j,t}$ are the voltage angles of nodes i and j , respectively, in time period t ; $y_{l(ij)}$ is the admittance of line l ; $\overline{F_{l(ij)}}$ is the power flow capacity of line l ; and $\overline{GP_g}$ is the maximum power production of unit g . The flow through l , $f_{l(ij),t}$, is positive when it takes place from node i to node j . Eq. (3.2) is the objective function whose value is to be minimized in the problem, which considers variable production costs, CO_2 emission costs and the costs due to energy not supplied; the energy

⁴⁴ For the sake of simplicity, this formulation considers a linearized version of the power flow (DC model) without line losses, a single circuit per line, and a single snapshot. However, the analysis carried out could be generalized to consider several snapshots, several circuits in each line, line losses, and even an AC formulation of the load flow. In fact, the example presented through this chapter considers several circuits. Besides, this formulation assumes that the power flow capacity in both directions of each line is the same and the minimum output of a generation unit is zero. However, it could also be generalized to consider a specific transmission capacity for the power flow in each direction in each line and non-zero minimum load for generation units.

balance equation for each node an time period is represented by (3.3) and Kirchhoff's second law (only applicable for AC lines, since here it is assumed that the flow in HVDC is fully controllable) is represented by (3.4). Eqs. (3.5)-(3.7) represent the upper and lower bounds of power flowing in each line, power produced by generators, and ENS, respectively.

3.2.4 General implementation of the method

As previously mentioned, the method proposed considers that the expansion projects within the plan are the players of the AS game. Applying AS involves dividing the investments undertaken within projects –increases in the transmission capacity, and/or admittance of lines, or corridors– into elemental projects so that the valuation of these investments is carried out in unit terms, regardless of the specific projects they belong to.

Expansion projects may consist of AC or HVDC investments. As just mentioned, the power flow through AC assets is modelled using a DC power flow model, and the power flow through HVDC assets is modelled using a transport power flow model (Kirchhoff's second law is not considered). Due to this modeling decision, corresponding to the assumption that the flow on each link of a multi-terminal HVDC network can be fully controlled separately from the flow on the rest of HVDC links, the admittance of HVDC assets or lines does not affect the operation of the power system.

Changes in the different dimensions of the size of each asset are considered when simulating the inclusion of a new elemental player in the great coalition of the AS game (i.e. deployment of a new elemental project or simulation of the gradual deployment of the expansion plan).

Only changes in the capacity are considered for HVDC assets, while both changes in the capacity and admittance are considered for projects involving AC assets. Thus, there are two possible approaches -hereafter referred to as approach a) and b)- to splitting each discrete AC expansion project into elemental parts:

- a) Considering that the capacity and admittance of transmission expansion projects, and the reinforcements associated with them, are related through a one-to-one correspondence: $y_{l(ij)} = h(\overline{F}_{l(ij)})$ ⁴⁵. The function $h(\cdot)$ links the initial and final values of the capacity and the initial and final values of the admittance of the expansion

⁴⁵ For example, the installation of a new AC line in the system results in an increase of both the capacity and the admittance of the transmission corridor where this line is installed. Thus, increases in the capacity and admittance of the affected transmission assets are intimately linked in this case, i.e. they can be considered to be related through a one to one correspondence.

projects, and the reinforcements associated with them. This function depends on the type of investment being undertaken.

- b) Assuming that both dimensions of the size of an expansion project are independent from one another, and therefore the reinforcement of an asset affected by the project can affect its capacity and admittance separately⁴⁶.

This parameterization of the size of expansion projects implies changes in (3.4) and/or (3.5) only for the assets being affected by the transmission expansion plan. In the case of AC expansion projects, if the capacity and the admittance of asset l are related, parameter λ_l is used to parameterize the evolution of the size of the expansion project. Then, (3.4)-(3.5) must be replaced by (3.8)-(3.9).

$$f_{l(ij),t} = (\theta_{i,t} - \theta_{j,t})h(\lambda_l \overline{F_{l(ij)}}) \quad \forall t, l(ij) \in TEP \quad (3.8)$$

$$-\lambda_l \overline{F_{l(ij)}} \leq f_{l(ij),t} \leq \lambda_l \overline{F_{l(ij)}} \quad \forall t, l(ij) \in TEP \quad (3.9)$$

Instead, if the capacity and admittance of this asset are independently affected by an expansion project, (3.4)-(3.5) must be replaced by (3.10)-(3.11). In this case, parameters $\lambda_{l,y}$ and $\lambda_{l,F}$ represent the separate evolution of the admittance and capacity of this asset.

$$f_{l(ij),t} = (\theta_{i,t} - \theta_{j,t})\lambda_{l,y}y_{l(ij)} \quad \forall t, l(ij) \in TEP \quad (3.10)$$

$$-\lambda_{l,F} \overline{F_{l(ij)}} \leq f_{l(ij),t} \leq \lambda_{l,F} \overline{F_{l(ij)}} \quad \forall t, l(ij) \in TEP \quad (3.11)$$

In the case of HVDC expansion projects, this parameterization only implies changes in (3.5), since the equation enforcing the 2nd Kirchhoff law does not apply to these assets. In this case, the parameter $\lambda_{l,F}$ may be used to represent the evolution of the capacity of this asset. Equation (3.11) can then be used to replace equation (3.5) corresponding to the assets affected by the HVDC expansion project.

As stated in section 3.2.1 in this chapter, the continuous increase in the size of assets affected by the expansion projects is represented by varying λ_l (capacity and admittance are related), $\lambda_{l,y}$ and $\lambda_{l,F}$ (capacity and admittance are independent), or $\lambda_{l,F}$ (only capacity affects the system operation) within the interval $[0,1]$. Note that, according to the formulation considered, reinforcements to existing transmission assets are considered new assets. Therefore, their initial capacity and admittance are set to zero.

⁴⁶ For example, lifting the utility poles of an already existing line only affects the capacity of the corresponding line (not the admittance). Furthermore, installing a FACTS (Flexible Alternating Current Transmission System) only affects the admittance of the line or corridor where it is located, since a FACTS can be considered a variable admittance. In the latter two cases, increases in the capacity and admittance of the affected transmission assets have to be considered independently.

Again, according to the law of large numbers, changes in parameter λ_l (or those in $\lambda_{l,y}$ and/or $\lambda_{l,F}$) can be considered the same for all projects in the plan. Therefore, a single parameter λ_l (or a single one, $\lambda_{l,y}$ and another single one, $\lambda_{l,F}$) can be used to represent the increase in the size of all expansion projects simultaneously. Thus, the K steps of the implementation of the AS algorithm can be deemed equivalent to simulate the gradual deployment of the expansion plan. And, as previously stated (see Section 3.2.1), the numerical computation of the integral in (3.1) in order to compute the benefits and beneficiaries provided by expansion projects can be performed by discretizing the variation of the single integration parameter λ_l in K values in the interval $[0,1]$. Of course, the accuracy of this numerical integration process is directly related to the number of steps taken in the value of parameter λ_l ⁴⁷.

Determining the benefit provided (effect produced in the characteristic function) by each elemental expansion project affecting a transmission asset l for the different levels of deployment of the expansion plan (steps k taken in the implementation of the AS process) requires comparing the SW, computed in (3.2)–(3.7), in two situations:

- 1) When capacity and/or admittance of expansion projects, and reinforcements associated to them, $\overline{F_{l(ij)}}$ and $y_{l(ij)}$, are those before the elemental project is implemented.
- 2) When the marginal reinforcement of asset l has taken place (the elemental project has been deployed). The definition of this second situation depends on the type of expansion project considered (AC or HVDC) and on how elemental reinforcements, or expansion projects, are defined:
 - a. In the case of AC assets, if the capacity and admittance of l are deemed related through a one-to-one correspondence, then both of them marginally increase.
 - b. In the case of AC assets, if the capacity and admittance of l are deemed independent, either the capacity or admittance of l shall increase marginally.

⁴⁷ The number of steps taken should be the minimum needed to compute an accurate enough estimate of the benefits produced by expansion projects. The lower the number of steps taken, the smaller the computational burden. In order to check if the number of steps is large enough, one can compare the sum of the benefits assigned to all expansion projects in the plan with the benefits resulting from the implementation of the whole expansion plan, which can be easily computed by comparing the system operation cost with and without the expansion plan in place. The more accurate the estimate of the benefits produced by expansion projects is, the closer the sum of the benefits assigned to all projects, B1, is to the global benefits produced by the expansion plan as a whole, B2. Then, a tolerance can be set for the absolute value of the difference between the ratio of B1 to B2 and 1.

- c. In the case of HVDC assets, only the capacity is increased marginally.

It is important to remark that there could be cases (as later explained in section 3.3.2 in this chapter) where the benefit function (the characteristic function to be allocated to projects or market agents) is not continuous with respect to the size of expansion projects. In other words, the evolution of the benefits obtained by market agents from the deployment of projects, which is modeled as taking place in K steps in the implementation process of AS (the simulation of the gradual deployment of expansion projects), is not continuous with respect to the level of deployment of these projects. Therefore, benefits assigned to the expansion projects can be of two different types:

- 1) Continuous benefits are the result of adding up the marginal benefits obtained from the deployment of the elemental expansion projects. These benefits are normally associated with the continuous change in the production of generation units and the ENS of consumers.
- 2) Discrete benefits occur as a result of discontinuities of the function of benefits to be allocated with respect to the size of expansion projects. In these cases, the discrete changes in benefits cannot only be assigned to the last elemental project deployed before these changes take place, since those benefits are also the responsibility of all those elemental projects that have been previously deployed and therefore, have also contributed to these discrete changes in benefits taking place⁴⁸.

The total benefits assigned to the expansion projects being assessed are obtained by adding up the continuous and –if they occur– discrete benefits caused by these projects.

The following sections provide all the details of the method just proposed to determine the global benefits in the dispatch –economic or of other types– produced by the expansion projects within a plan, as well as the fraction of these benefits obtained by each party.

3.3 PARTICULARIZATION OF THE METHODOLOGY TO ESTIMATE THE ECONOMIC BENEFITS PRODUCED BY EXPANSION PROJECTS IN THE OPERATION OF THE POWER SYSTEM

This section explains in detail the method proposed to calculate the economic benefits produced in the dispatch by the projects that comprise an expansion plan and the benefits obtained by individual network users (beneficiaries) from these expansion projects.

⁴⁸ The approach developed to allocate the discrete benefits of network users to expansion projects is an important contribution of this thesis. It is further discussed in section 3.3.2.2.

3.3.1 Description of the methodology to determine the benefits of expansion projects

The Aumann-Shapley method proposed involves splitting expansion projects (and the investments comprised) into elemental expansion projects. In this case, the AS concept is applied in order to assign the benefits obtained by the system from the expansion plan to the projects that comprise it. Using cooperative game jargon, the main concepts considered in this game are defined next:

- The characteristic function is the increase in SW. The increase in SW corresponds to the function $f(\mathcal{S})$ previously mentioned when introducing the method.
- The players in the game are the expansion projects, which are an input to the method.
- The size of the players relates to the increase in the transmission capacity ($\overline{F}_{l(ij)}$), and admittance ($y_{l(ij)}$) of assets caused by the deployment of the expansion projects.
- The great coalition is the expansion plan, or group of projects, decided at the planning stage.

The authors in (Olmos et al. 2013) have developed analytical expressions to compute the marginal impact of changes to line parameters on the cost of the economic dispatch. According to (Olmos et al. 2013), if the capacity and admittance of each asset l are related through a one-to-one correspondence (approach a) in section 3.2.4), the marginal benefit in the dispatch produced by a marginal change in the size of this asset for each time period t can be computed using (3.12). The reader should note that this is the benefit of deploying an elemental project affecting asset l .

$$\left(\frac{\partial Ben}{\partial l}\right)_t = \tau_{f_{l,t}} f_{l,t} \frac{h'(\lambda_l \overline{F}_l)}{h(\lambda_l \overline{F}_l)} - \gamma_{f_{l,t}}^+ - \gamma_{f_{l,t}}^- \quad (3.12)$$

where $\tau_{f_{l,t}}$ is the dual variable of the equation (3.4) determining the flow through l ; h' is the derivative of h ⁴⁹; and $\gamma_{f_{l,t}}^+$ and $\gamma_{f_{l,t}}^-$ are the dual variables of (3.5) setting an upper and lower limit to the flow through l , respectively.

If capacity and admittance of asset l associated with expansion projects are assumed to be independent from one another (approach b) in section 3.2.4), the marginal benefit in the dispatch produced by elemental expansion projects for each time period t is defined in terms of the capacity of each asset l , \overline{F}_l , on the one hand, and/or its admittance, y_l , on the

⁴⁹ Remember that the function $h(\cdot)$, which depends on the type of investment, links the initial and final values of the capacity and the initial and final values of the admittance of the expansion projects, and the reinforcements associated with them.

other. As derived in (Olmos et al. 2013), the benefits of a marginal change in the capacity of asset l for each time period t can be computed according to (3.13).

$$\left(\frac{\partial Ben}{\partial \bar{F}_l}\right)_t = -\gamma_{f_l,t}^+ - \gamma_{f_l,t}^- \quad (3.13)$$

while the benefits produced by a marginal change in the admittance of asset l for each time period t is computed as in (3.14).

$$\left(\frac{\partial Ben}{\partial y_{l(ij)}}\right)_t = \tau_{f_l,t}(\theta_{i,t} - \theta_{j,t}) \quad (3.14)$$

In the case of HVDC expansion projects, as previously mentioned, it can be considered that the Kirchoff's 2nd law does not apply to these assets. Therefore, only the capacity of these assets affects system operation. Hence, the marginal benefit in the dispatch produced by elemental expansion projects of this type for each time period t is defined in terms of the capacity of each asset l , \bar{F}_l . Please note that, in this case, the expression to compute the benefits of a marginal change in the capacity of asset l for each time period t coincides with the benefits of a marginal change in the capacity of asset l when capacity and admittance are assumed to be independent (3.13).

Note that (3.12) and (3.13)-(3.14) are expressed in terms of system operation variables and dual variables of constraints that are computed, as a byproduct, when solving the economic dispatch problem for each time period t .

As previously stated, the benefits provided by expansion projects can be calculated using a discretized version of (3.1). The increase in social welfare in each time period t , $\Delta Ben_k^{l(ij),t}$, achieved by reinforcing $l(ij)$ in each discrete step k of the process of the AS algorithm (simulated process of gradual deployment of the expansion plan), when the capacity and admittance of an expansion project, and the reinforcement of asset l associated with it, are related through a one-to-one correspondence (approach a) in section 3.2.4), is calculated according to (3.15).

$$\Delta Ben_k^{l,t} = \left(\frac{\partial Ben}{\partial l}\right)_k^t \Delta l_k \quad (3.15)$$

where Δl_k is the increase in the size of l and $\left(\frac{\partial Ben}{\partial l}\right)_k^t$ is the derivative of system benefits with respect to a change in the size of l , in step k of the process of deployment of all elemental projects in the expansion plan (deployment of the expansion plan) for the time period t .

For the case when the capacity and admittance of an expansion project, and therefore the reinforcement of an asset l affected by this project, are assumed to be independent from

one another (approach b) in section 3.2.4), the process is completely analogous⁵⁰. Parameters $\lambda_{l,y}$ and $\lambda_{l,F}$ represent the deployed fraction of all the elemental expansion projects affecting the admittance and capacity of transmission assets built within the expansion plan, respectively. The increase in SW for each time period t caused in each step k of the process of deployment of the expansion plan by independently reinforcing the capacity and admittance of asset $l(ij)$ are calculated according to (3.16) and (3.17), respectively.

$$\Delta Ben_k^{l,t} = \left(\frac{\partial Ben}{\partial \overline{F}_l} \right)_k^t \Delta \overline{F}_{l,k} \quad (3.16)$$

$$\Delta Ben_k^{l,t} = \left(\frac{\partial Ben}{\partial y_{l(ij)}} \right)_k^t \Delta y_{l,k} \quad (3.17)$$

where $\Delta \overline{F}_{l,k}$ and $\Delta y_{l,k}$ are the increases in the capacity and admittance of asset l , respectively, and $\left(\frac{\partial Ben}{\partial \overline{F}_l} \right)_k^t$ and $\left(\frac{\partial Ben}{\partial y_{l(ij)}} \right)_k^t$ are the derivatives of system benefits with respect to a change in the capacity and admittance of $l(ij)$ in step k of the implementation process of the expansion plan for each time period t .

In the case of HVDC expansion projects, the increase in SW for each time period t caused in each step k of the process of deployment of the expansion plan coincides with (3.16).

Benefits are computed for each step increase Δl_k , $\Delta y_{l,k}$ and $\Delta \overline{F}_{l,k}$, or $\Delta \overline{F}_{l,k}$ (depending on the type of expansion project considered) in the size of asset l caused by the deployment of elemental projects in the plan. Then, the benefit of the expansion project affecting asset l for each time period t is computed as the sum of the benefits $\Delta Ben_k^{l,t}$ corresponding to all the steps k considered in the process of deployment of the elemental projects in the plan obtained in time period t , (3.18).

$$Ben^{l,t} = \sum_k \Delta Ben_k^{l,t} \quad (3.18)$$

Finally, the total benefits of the expansion project affecting asset l are computed as the sum of the benefits of this project corresponding to all the time periods t considered, $Ben^{l,t}$, multiplied by the weight (or duration) associated to each time period W_t , (3.19). This weight (or duration) represents the duration in hours of each time period considered

⁵⁰ Notice that the case when transmission admittance and capacity are independent from each other, and the case when they are related through a one-to-one correspondence produce the same subset of permutations. Thus, $\lambda_l = \lambda_{l,y} = \lambda_{l,F}$ for each step k .

for the target year of operation. Thus, the sum of these weights is equal to the number of hours of the target year.

$$Ben^l = \sum_t W_t \cdot Ben^{l(ij),t} \quad (3.19)$$

The diagram in Fig. 3.1 illustrates the process of application of the method described in this section to compute the benefits provided by expansion projects. I solve K optimal power flow (OPF) and economic dispatch (ED) problems corresponding to the K steps taken in the implementation of the AS algorithm, which simulates the gradual deployment of expansion projects in the plan. For each problem k , the OPF and ED problems are solved and, then, the variables and dual variables from the optimal solution of the problem are obtained. Then, they are used to compute the marginal benefits resulting from the marginal deployment of projects in the plan in each step. These benefits are saved in each iteration k . Finally, when all the K steps have been considered (the whole expansion plan is deployed in the simulated process of deployment), the total benefits provided by expansion projects are calculated.

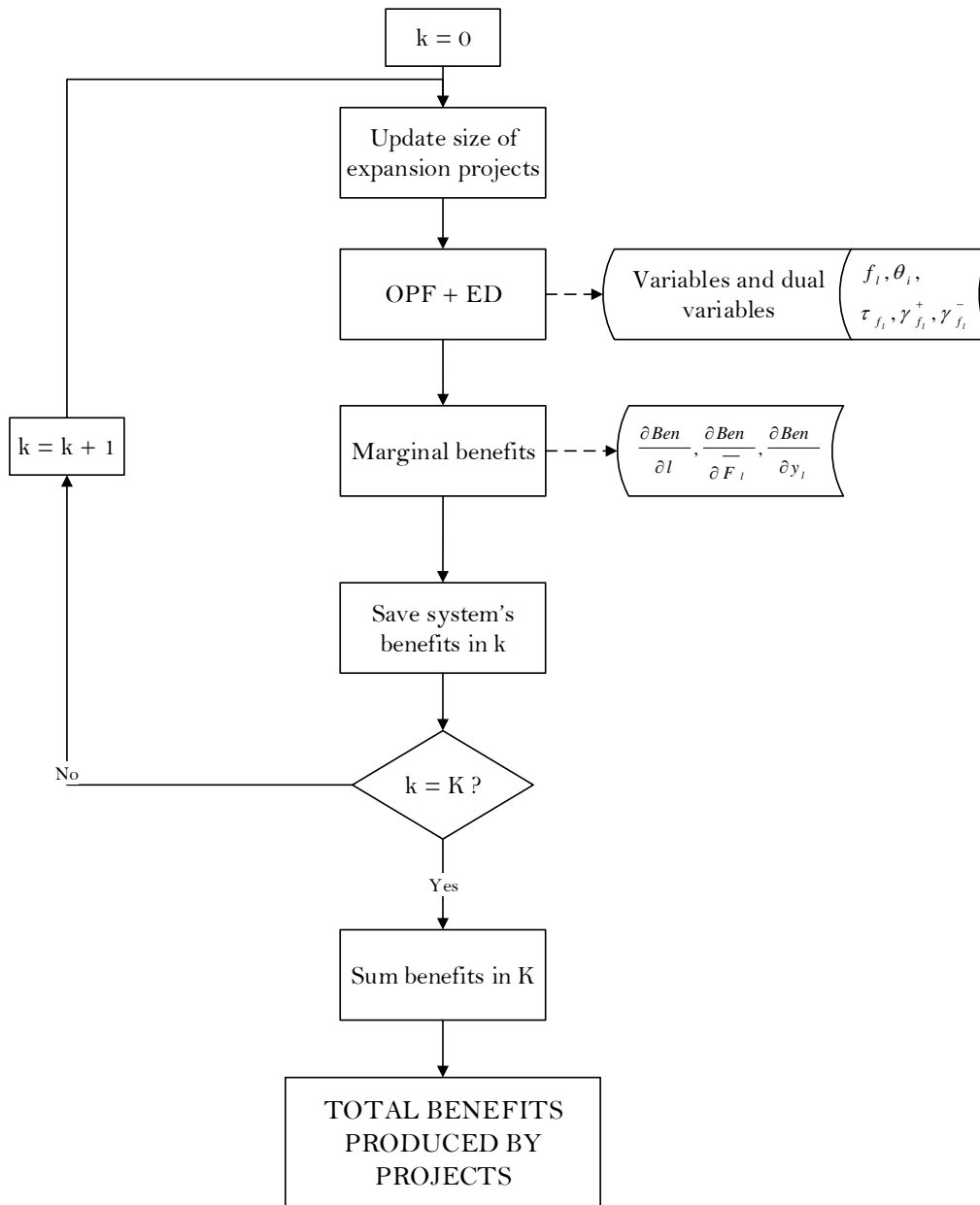

Fig. 3.1. Simplified scheme of application of the proposed method to determine the benefits of individual expansion projects for each time period t considered. All data required to calculate project's benefits is obtained by solving K optimal power flow and economic dispatch problems.

Illustrative example: application of AS to determine the benefits of expansion projects

Let us go back to the illustrative example employed in the previous chapter (Fig. 3.2 reproduces this example here for the sake of clarity).

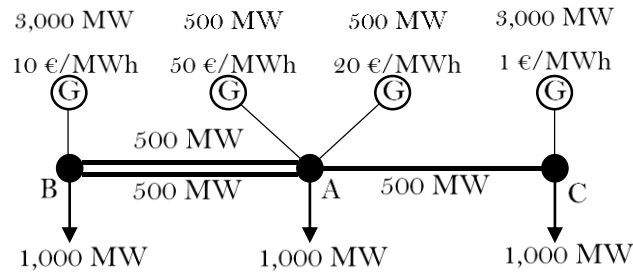

Fig. 3.2. 3-bus power system schematic representation. This power system was first introduced in Chapter 2.

The implementation made of AS involves simulating the gradual deployment of the expansion plan and integrating in discrete steps the benefits obtained by the system in this process. These discrete steps correspond to the deployment of the elemental projects that real expansion projects have been divided into. In order to apply the method, a linear relationship is assumed between the transmission capacity and admittance of expansion projects ($y_{l(ij)} = \alpha \overline{F_{l(ij)}}$), because all the projects are full AC lines.

Fig. 3.3 displays the ED and OPF results (productions and power flows in lines) computed in all the steps of the process. In the first steps, elemental projects deployed reduce, and eventually fully avoid the production with the most expensive generator –unit A1– in the system (located in node A) and enable the production with the cheaper units located in nodes B and C. Note that the deployment of the elemental projects causes an increase in the power flow through the corresponding expansion projects.

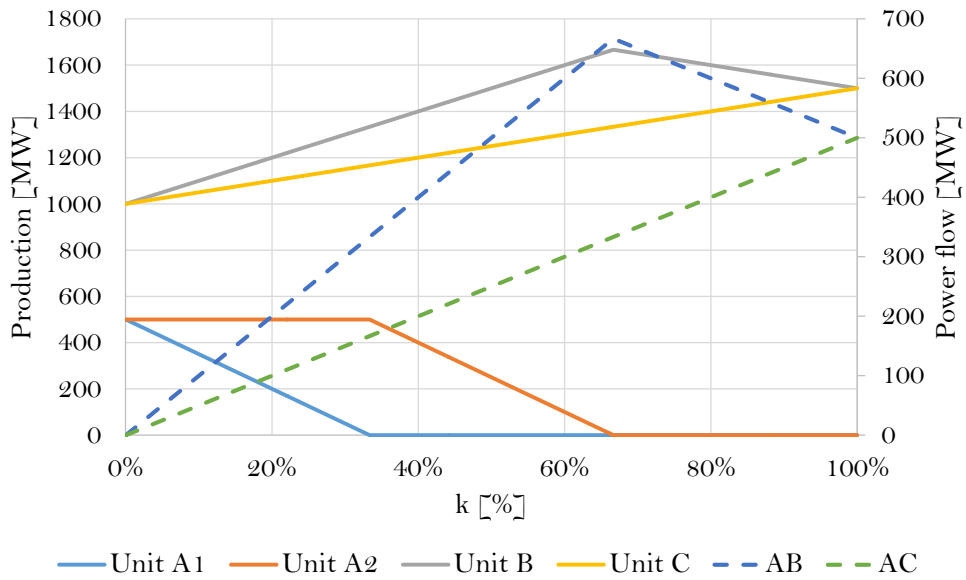

Fig. 3.3. Evolution of the production of the different generator units (continuous lines and left axis) and the power flow of the expansion projects (dashed lines and right axis) through all the steps k of the application of the AS approach (gradual deployment of the plan simulated in AS).

As soon as the unit A1 stops producing energy, it is replaced as the marginal unit by unit A2 and then, the price in node A is reduced to 20€/MWh, as can be seen in Fig. 3.4.

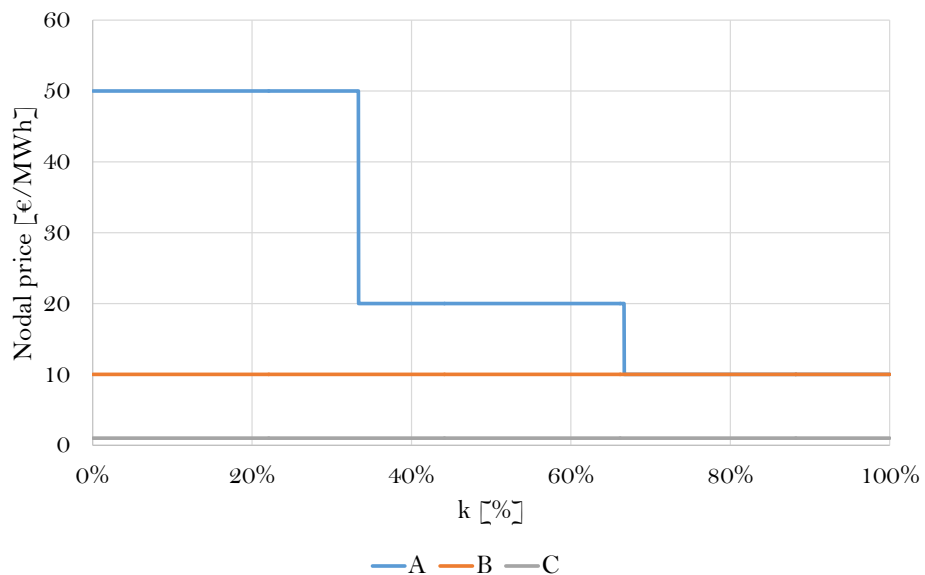

Fig. 3.4. Evolution of the nodal prices through all the steps k of application of the AS approach (gradual deployment of the plan simulated in AS).

As indicated in (Olmos et al. 2013), if the admittance of a project is a linear function of the capacity of this project, the marginal benefit of an expansion project in (3.12) can be simplified as in (3.20).

$$\left(\frac{\partial Ben}{\partial l(ij)}\right)_t = (\mu_{j,t} - \mu_{i,t}) \frac{f_{l,t}}{F_i} \quad (3.20)$$

where $\mu_{i,t}$ and $\mu_{j,t}$ are the marginal prices at nodes i and j , respectively, for each time period t (marginal prices for all the nodes are available in Fig. 3.4).

Using this expression, the marginal benefits of expansion projects throughout the whole process of deployment of the expansion plan, which are displayed in Fig. 3.5, can be computed. The sum of the marginal benefits of both projects is equal to the slope of the curve of evolution of the system benefits with the deployment of the expansion plan (i.e. marginal benefits of the system for this deployment process in each step of it), which is displayed later in Fig. 3.7.

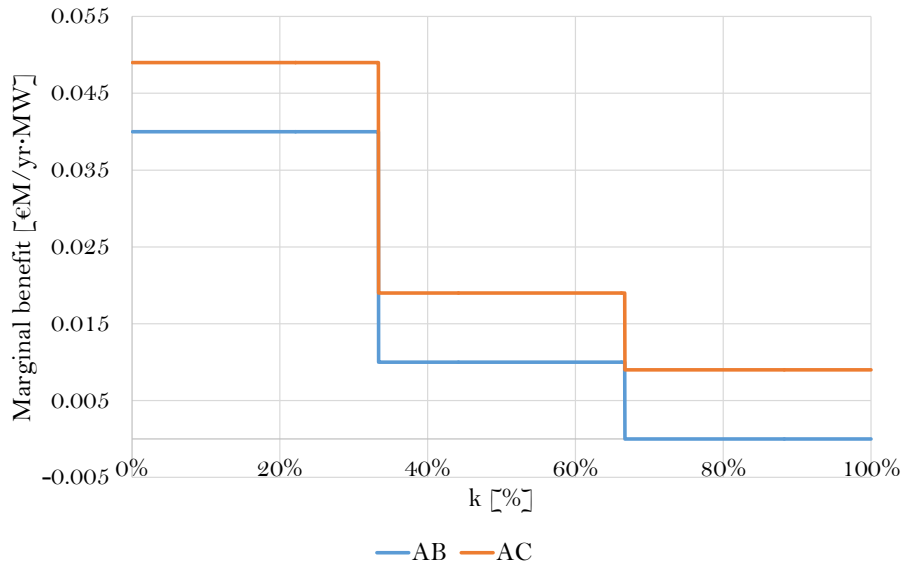

Fig. 3.5. Evolution of the marginal benefits provided by expansion projects through all the steps k of application of the AS approach (gradual deployment of the plan simulated in AS).

Finally, the benefits of expansion projects are computed using (3.15) and (3.18)-(3.19), resulting in benefits of €146M/yr and €112M/yr for projects AB and AC, respectively.

Although the marginal benefits of project AC are higher than the marginal benefits of project AB, the overall benefits of expansion project AB are higher than those of

project AC. This is so because project AB would be able to provide more benefits if project AC were not deployed, or, at least, not fully deployed, than those that would be produced by project AC in the absence of project AB (project AB is able to play the same function as project AC, in some way). Please note that if project AC was not deployed (or not fully deployed), the flow through the assets in project AB would increase. On the contrary, the flow through the assets in project AC could not increase if project AB is not deployed, since the line comprising project AC is already congested when project AB is deployed.

3.3.2 Description of the methodology to determine the benefits obtained by individual users from expansion projects

In the previous sub-section, the benefit allocation method proposed to compute the increase in SW –total benefits– provided by expansion projects in the economic dispatch was particularized. But the SW can also be seen as the sum of the benefits obtained by the different network users of the power system: generators, consumers and transmission owners (TOs). Therefore, the objective of this sub-section is to describe the method to be applied to compute the benefits obtained by individual network users (beneficiaries) of the power system from expansion projects.

In order to compute the beneficiaries of the expansion projects included in the plan –and their benefits–, each network user of the system must be considered separately. However, the AS game to be formulated for the computation of the benefits obtained by each user depends on its type: consumers, generators and transmission owners. Using cooperative game jargon, the main concepts of the AS games to model are defined next:

- The characteristic function, which is the function of the social benefits resulting from the system dispatch, is here decomposed into the benefits of each generator (3.21), consumer (3.22) and transmission owner (3.23) in the system. The benefit of each user corresponds to the function $f(S)$ previously mentioned when introducing the method. Thus, I can assume that the overall characteristic function of the game of allocation of the benefits of users to expansion projects comprises in reality many functions, each one representing the benefit of each user in the dispatch.
- The players in the game are the expansion projects, which are an input to the method.
- The size of the players is related to the increase in the transmission capacity ($\overline{F}_{l(ij)}$), and admittance ($y_{l(ij)}$) of assets affected by the deployment of the expansion projects.

- The great coalition is the expansion plan decided at the network expansion planning stage.

Note that, formally speaking, solving this cooperative game involves allocating the benefits obtained by each user from the expansion plan to the expansion projects within the plan, which is equivalent to computing the beneficiaries of these projects.

It is interesting to remark that AS has been already applied in previous works by other authors to compute the benefits obtained by network users (generators and demands) from the transmission lines of the network in order to allocate their cost⁵¹. In these previous works, the use made by the network users of the transmission lines is considered as a proxy of the benefits. This approach allocates the power generated (power consumed) by generation units (by consumers) among the transmission lines that carry this power. This way, the players of the cooperative game are, in this case, the network users. However, generators and demands are not considered as players of the same game, instead they are considered separately, i.e. two separate games are formulated: one for generators and another for demands. The total cost to be allocated is therefore split between generators and consumers according to a relative weight that is usually established ex-ante, e.g. this relative weight can be 50%-50%, so that the total cost is paid 50% by generators and 50% by consumers according to their use, or 90%-10%, so that generators paid 90% of the total cost and the consumers paid the remaining 10%. Another limitation of this approach is that it is not able to distinguish between different possible uses of the lines, and then the benefits provided, e.g. a line that reduces the ENS probably provides more benefits than another line that “only” enables a cheaper generation unit to be dispatched. As it will be seen through this section (and in the case studies presented in Chapter 4), the proposed method overcomes these limitations.

If a nodal pricing scheme is assumed, the benefits obtained by a generator (g) in the energy dispatch amount to its revenues from the sale of electricity produced (gp_g), valued at the spot price where this generator is located ($\mu_{i(g \in i)}$), minus the variable costs incurred by this generator (VC_g) when producing the energy sold, (3.21). Each consumer (c) obtains a benefit in the energy dispatch that is equal to the utility it obtains from the electricity it consumes (VB_c) less the cost of purchasing this electricity at the corresponding spot price ($\mu_{i(c \in i)}$), (3.22). The revenues of each TO ($l(ij)$) in the dispatch are the congestion rents resulting from the application of spot prices to the energy produced and consumed in the network, or set of lines, it owns. Congestion rents produced by each line in the dispatch correspond to the difference between spot prices at

⁵¹ Please see section 3.1 for more details.

both ends of this line times the power flow in the line ($f_{l(ij)}$), (3.23). These benefits (3.21)-(3.23) should be computed for each time period or operation situation t of the set of them considered.

$$GB_g^t = (\mu_{i(g \in i)}^t - VC_g)gp_g^t \quad (3.21)$$

$$CB_c^t = (VB_c - \mu_{i(c \in i)}^t)(D_c^t - ens_c^t) \quad (3.22)$$

$$TB_{l(ij)}^t = (\mu_j^t - \mu_i^t)f_{l(ij)}^t \quad (3.23)$$

where $l(ij)$ are the lines and TO the transmission owners (it is assumed that every line has a different TO by default); GB_g^t , CB_c^t , $TB_{l(ij)}^t$ are the generators', consumers' and TOs' benefits in the dispatch for each time period t ; μ_i^t and μ_j^t are the marginal prices at nodes i and j , respectively, for each time period t ; $g \in i$ are the generators located in node i (more than one generator could be located in each node); D_c^t is the power consumption of consumer c for each time period t ; ens_c^t is the amount of energy demanded by consumer c that is not served in each time period t ; $f_{l(ij)}^t$ is the power flow through line l , which connects nodes i and j , for each time period t . Note that these benefits can then be summed up to obtain the social benefits of whole areas, countries or regions.

Similarly to the what occurs in the computation of the global benefits of projects, and as previously stated (see section 3.2.4), the numerical computation of the integral in (3.1) for each user can be carried out by discretizing the variation of the single integration parameter λ_l in K values in the interval $[0,1]$ ⁵². Nevertheless, in this case, the reader should note that the benefits obtained by the users of the electricity transmission network (generators, consumers, and TOs) from the gradual deployment of projects in the plan (i.e., the K steps of the implementation of the AS algorithm) are not always continuous. In other words, the benefit functions of network users, (3.21)-(3.23), are not always continuous with respect to the size of expansion projects. This is so because nodal prices may abruptly change (undergo a discrete change) when there is a change in the marginal generation unit in the system dispatch. Therefore, benefits obtained by users from the continuous, or gradual, deployment of expansion projects in the plan, simulated when applying the AS algorithm for computing the overall benefits obtained by network users from these projects, can be of two types:

- 1) Benefits resulting from the continuous change in the production of generation units, the ENS of consumers, power flow through the lines and nodal prices of the power

⁵² Please, see footnote 47 for details about the accuracy of this numerical integration.

system, as considered in benefit functions in (3.21)-(3.23). These are called continuous benefits.

- 2) Benefits resulting from a discrete change in nodal prices and, then, in the benefits obtained by network users. Discrete changes in the nodal prices occur when a generation unit replaces another generator as the marginal unit in the economic dispatch. These benefits normally correspond to a redistribution of the system benefits among the different users of the transmission network (the ones being affected by the concerned discrete change in nodal prices). These are called discrete benefits.

The total benefits obtained from the expansion projects within a plan by the individual network users correspond to the sum of the continuous and discrete benefits caused by these projects. The computation of the continuous and discrete benefits obtained by network users from each project are formulated separately.

3.3.2.1 Continuous benefits obtained by network users from expansion projects

When applying (3.1), if benefits produced by the gradual deployment of expansion projects (when applying the AS method) are continuous, the marginal benefit that each network user obtains from the undertaking of an elemental project that affects asset l can be computed using (3.24)-(3.26) for every λ_l , or $\lambda_{l,y}$ and $\lambda_{l,F}$. These equations are obtained by deriving (3.21)-(3.23) with respect to the size of asset l . Note that (3.24)-(3.26) only include system variables and dual variables computed when solving the economic dispatch problem, and sensitivities of these variables $\left(\frac{\partial gp_g}{\partial l(ij)}, \frac{\partial \mu_n}{\partial l(ij)}, \frac{\partial ens_c}{\partial l(ij)} \text{ and } \frac{\partial f_{l'}}{\partial l(ij)}\right)$ that can also be obtained from the solution of this problem⁵³.

$$\left(\frac{\partial GB_g}{\partial l(ij)}\right)_t = (\mu_{n(g \in n)}^t - VC_g) \left(\frac{\partial gp_g}{\partial l(ij)}\right)_t + \left(\frac{\partial \mu_n}{\partial l(ij)}\right)_t gp_g^t \quad (3.24)$$

$$\left(\frac{\partial CB_c}{\partial l(ij)}\right)_t = -(D_c^t - ens_c^t) \left(\frac{\partial \mu_n}{\partial l(ij)}\right)_t - (VB_c - \mu_c^t) \left(\frac{\partial ens_c}{\partial l(ij)}\right)_t \quad (3.25)$$

$$\left(\frac{\partial TB_{l'}(ij)}{\partial l(ij)}\right)_t = f_{l'}^t \left(\frac{\partial \mu_{j'}}{\partial l(ij)} - \frac{\partial \mu_{i'}}{\partial l(ij)}\right)_t + (\mu_{j'}^t - \mu_{i'}^t) \left(\frac{\partial f_{l'}}{\partial l(ij)}\right)_t \quad (3.26)$$

where $\left(\frac{\partial GB_g}{\partial l(ij)}\right)_t$, $\left(\frac{\partial CB_c}{\partial l(ij)}\right)_t$, $\left(\frac{\partial TB_{l'}(ij)}{\partial l(ij)}\right)_t$ are the marginal benefits in each time period t that a generator g , a consumer c and the owner of a transmission asset l' obtain from a marginal increase in the size of asset l affected by an elemental project, respectively; $\frac{\partial gp_g}{\partial l(ij)}$, $\frac{\partial \mu_n}{\partial l(ij)}$,

⁵³ For more details about the calculation of these marginal increases or sensitivities, the reader is referred to Appendix A.

$\frac{\partial \text{ens}_c}{\partial l(ij)}$ and $\frac{\partial f_{l'}}{\partial l(ij)}$ are the marginal changes taking place in the production of g , the marginal price at node n , the ENS of consumer c , and the power flow through line l' , respectively, in each time period t , when there is a marginal increase in the size of asset l due to the implementation of an elemental project.

Therefore, the contribution of each expansion project to the continuous benefits obtained by each network user can be calculated by solving the AS game just formulated. This game is formulated in terms of the derivatives of the continuous benefits of users with respect to the size of the aforementioned project, see (3.24)-(3.26).

3.3.2.2 Discrete benefits obtained by network users from expansion projects

As mentioned above, discrete changes in the benefits of network users are associated with discrete changes in energy –nodal– prices, which are caused by changes in the marginal generation unit in the economic dispatch. In optimization jargon, changes in the marginal generation unit are caused by changes in the set of basic variables of the economic dispatch problem. In other words, the marginal generation unit changes because a basic variable of the economic dispatch problem reaches its upper or lower bound, becomes a non-basic variable, and is replaced by another variable in the basis. Therefore, a change in the marginal generation unit is actually caused by those specific network investments having previously led to changes in the value of the basic variable that is eventually leaving the basis of the dispatch problem when this change in the marginal generation unit takes place.

Then, applying the causality criterion, one can state that the contributions of individual projects to the discrete benefits obtained by users can be deemed to coincide with the contributions of these same projects to those changes in a variable eventually leading this variable to leave the problem basis when the aforementioned discrete benefits occur⁵⁴. But changes taking place in the variable leaving the basis of the problem are generally continuous with the level of deployment of expansion projects. Consequently, the contributions of individual projects to changes in a basic variable of the problem can be formulated as an AS game, as previously done for the computation of the contributions of projects to the continuous benefits obtained by users from the development of the grid.

⁵⁴ A similar problem is caused in energy pricing by the discrete nature and cost associated with start-up and other operation decisions made by generation units. Analogously to the benefit allocation method we propose, some electricity pricing schemes involve the application of uplifts on marginal prices to prevent agents from incurring a loss when making the decision to start-up a unit to produce power (Liberopoulos & Andrianesis 2014).

First, for each time period t , the change in the problem basis in step k (formally between k and $k-1$) and thus, the variable leaving the basis when this change occurs, are detected. Then, discrete changes in the benefits of users, in each time period t , occurring at step k of the AS algorithm (simulated process of gradual deployment of the expansion plan) can be computed as in (3.27)-(3.29).

$$\Delta GB_g^{k,t} = \Delta \mu_{i(g \in i)}^{k,t} gp_g^{k-1,t} = \Delta \mu_{i(g \in i)}^{k,t} gp_g^{k,t} \quad (3.27)$$

$$\Delta CB_c^{k,t} = -\Delta \mu_{i(c \in i)}^{k,t} (D_c^t - ens_c^{k-1,t}) = \Delta \mu_{i(c \in i)}^{k,t} (D_c^t - ens_c^{k,t}) \quad (3.28)$$

$$\Delta TB_{l(ij)}^{k,t} = (\Delta \mu_j^{k,t} - \Delta \mu_i^{k,t}) f_{l(ij)}^{k-1,t} = (\Delta \mu_j^{k,t} - \Delta \mu_i^{k,t}) f_{l(ij)}^{k,t} \quad (3.29)$$

where $\Delta \mu_i^{k,t}$, $\Delta \mu_j^{k,t}$ are the incremental changes in the marginal price of nodes i and j between steps $k-1$ and k , respectively, in each time period t and $gp_g^{k,t}$, $ens_c^{k,t}$ and $f_{l(ij)}^{k,t}$ are the production of unit g , the amount of ENS in node c and the flow through l in step k of the process, respectively⁵⁵, for each time period t .

The AS game formulated to compute the contribution of individual projects to the discrete benefits of users in (3.27)-(3.29) is analogous to that described at the beginning of this section, except for the characteristic functions considered. The new characteristic functions are the changes undergone by the variable leaving the problem basis up to the step when this change in the basis occurs and the corresponding discrete benefits are realized. Variables leaving the basis of the dispatch problem can be (a) the production of a generation unit; (b) the ENS in a node, which may begin to grow starting from zero or may become zero having previously been larger⁵⁶; or (c) the power flow through a line, which may reach its limit (line capacity).

If the variable leaving the basis in step k for time period t is the production of generation unit g' , the relative contribution of an expansion project l to the change in the production of this unit for this time period t ($Cgp_g^{l,t}$) is computed according to (3.30). This results from dividing the total change caused by this project in the production of g' in t ($Vgp_g^{l,t}$), which is calculated according to the new AS game using (3.31), by the sum of the overall changes caused by every project of the plan in the production of this same unit for this same time period t .

⁵⁵ Note that if K is large enough, gp_g^k , ens_c^k and $f_{l(ij)}^k$ would be equal to gp_g^{k-1} , ens_c^{k-1} and $f_{l(ij)}^{k-1}$, respectively.

⁵⁶ This is equivalent to having the power production by the virtual generator supplying ENS at this node increasing beyond zero or becoming zero.

$$Cgp_{g'}^{l,t} = \frac{Vgp_{g'}^{l,t}}{\sum_{l'}^{TEP} Vgp_{g'}^{l',t}} \quad (3.30)$$

$$Vgp_{g'}^{l,t} = \sum_{k'} \left(\frac{\partial gp_{g'}}{\partial l} \right)_{k'}^t \Delta l_{k'} \quad k' < k \quad (3.31)$$

Finally, the discrete benefits of users, in each time period t , taking place in step k of the simulated process of gradual deployment of the expansion plan are allocated to individual projects based on their relative contribution to the variation of the level of the production of g' eventually leading to the change in the marginal generation unit at this step k , as in (3.32)-(3.34).

$$DGB_{g,k}^{l,t} = \Delta GB_g^{k,t} \cdot Cgp_{g'}^{l,t} \quad (3.32)$$

$$DCB_{c,k}^{l,t} = \Delta CB_c^{k,t} \cdot Cgp_{g'}^{l,t} \quad (3.33)$$

$$DTB_{l',k}^{l,t} = \Delta TB_{l'}^{k,t} \cdot Cgp_{g'}^{l,t} \quad (3.34)$$

Discrete benefits, in each time period, occurring when the ENS of consumer c' , or the power flow through line l'' are the variables leaving the problem basis in step k of the AS process (deployment of the expansion plan) and can be calculated in an analogous way:

- The contribution $Cgp_{g'}^{l,t}$ in (3.30) and in (3.32)-(3.34) should be replaced by $Cens_{c'}^{l,t}$ or $Cf_{l''}^{l,t}$, respectively.
- The overall change in the level of the variable leaving the basis caused by each project l , $Vgp_{g'}^{l,t}$, previously computed as in (3.31), should be replaced, both in (3.30) and (3.31), by $Vens_{c'}^{l,t}$ or $Vf_{l''}^{l,t}$, respectively. Then, in (3.31), $\frac{\partial gp_{g'}}{\partial l}$ would also be replaced by $\frac{\partial ens_{c'}}{\partial l}$ or $\frac{\partial f_{l''}}{\partial l}$.

Then, the total benefits obtained by each network user, which are allocated to each expansion project l in each time period t (considering both continuous and discrete benefits), are determined according to (3.35)-(3.37). Note that when discrete benefits occur in step k , the sum of the continuous and discrete benefits of users in this step are computed jointly as the change in the benefits of users in this step k (difference in the benefits of users between steps k and $k-1$)

$$GB_g^{l,t} = \sum_{k=1}^K \left(\frac{\partial GB_g}{\partial l} \right)_k^t \Delta l_k + DGB_{g,k}^{l,t} \quad (3.35)$$

$$CB_c^{l,t} = \sum_{k=1}^K \left(\frac{\partial CB_c}{\partial l} \right)_k^t \Delta l_k + DCB_{c,k}^{l,t} \quad (3.36)$$

$$TB_{l'}^{l,t} = \sum_{k=1}^K \left(\frac{\partial TB_{l'}}{\partial l} \right)_k^t \Delta l_k + DTB_{l',k}^{l,t} \quad (3.37)$$

Finally, the total benefits obtained by each individual network user from each expansion project l are computed as the sum of the benefits of each user allocated to each expansion project over all the time periods t considered, $GB_g^{l,t}$, $CB_c^{l,t}$, $TB_{l'}^{l,t}$, multiplied by the weight (or duration) associated to each time period W_t , (3.38)-(3.40).

$$GB_g^l = \sum_t W_t \cdot GB_g^{l,t} \quad (3.38)$$

$$CB_c^l = \sum_t W_t \cdot CB_c^{l,t} \quad (3.39)$$

$$TB_{l'}^l = \sum_t W_t \cdot TB_{l'}^{l,t} \quad (3.40)$$

The diagram in Fig. 3.6 illustrates the process of application of the proposed method. I solve K optimal power flow and economic dispatch problems corresponding to the K steps taken in the implementation of the AS algorithm (simulated process of deployment of the expansion plan). For each problem k , I solve the OPF and ED problems and, then, obtain the basis⁵⁷ of the optimal solution (as well as the variables and dual variables of the optimal solution). Then, I compute the discrete or continuous (marginal) benefits resulting from the marginal deployment of projects in the plan, depending on whether or not a change in the basis of the economic dispatch problem occurs in this step k . These benefits are saved in each iteration k . Once the K steps have been taken, the discrete benefits obtained by each network user are allocated to expansion projects, as described above. Finally, we calculate the benefits obtained by users from projects as the sum of the continuous and discrete benefits of users attributable to each of these projects.

⁵⁷ The basis of the problem can be defined as the set of basic variables that comprise the optimal solution of the problem. The basic variables are those whose level is neither at its lower nor at its upper bound.

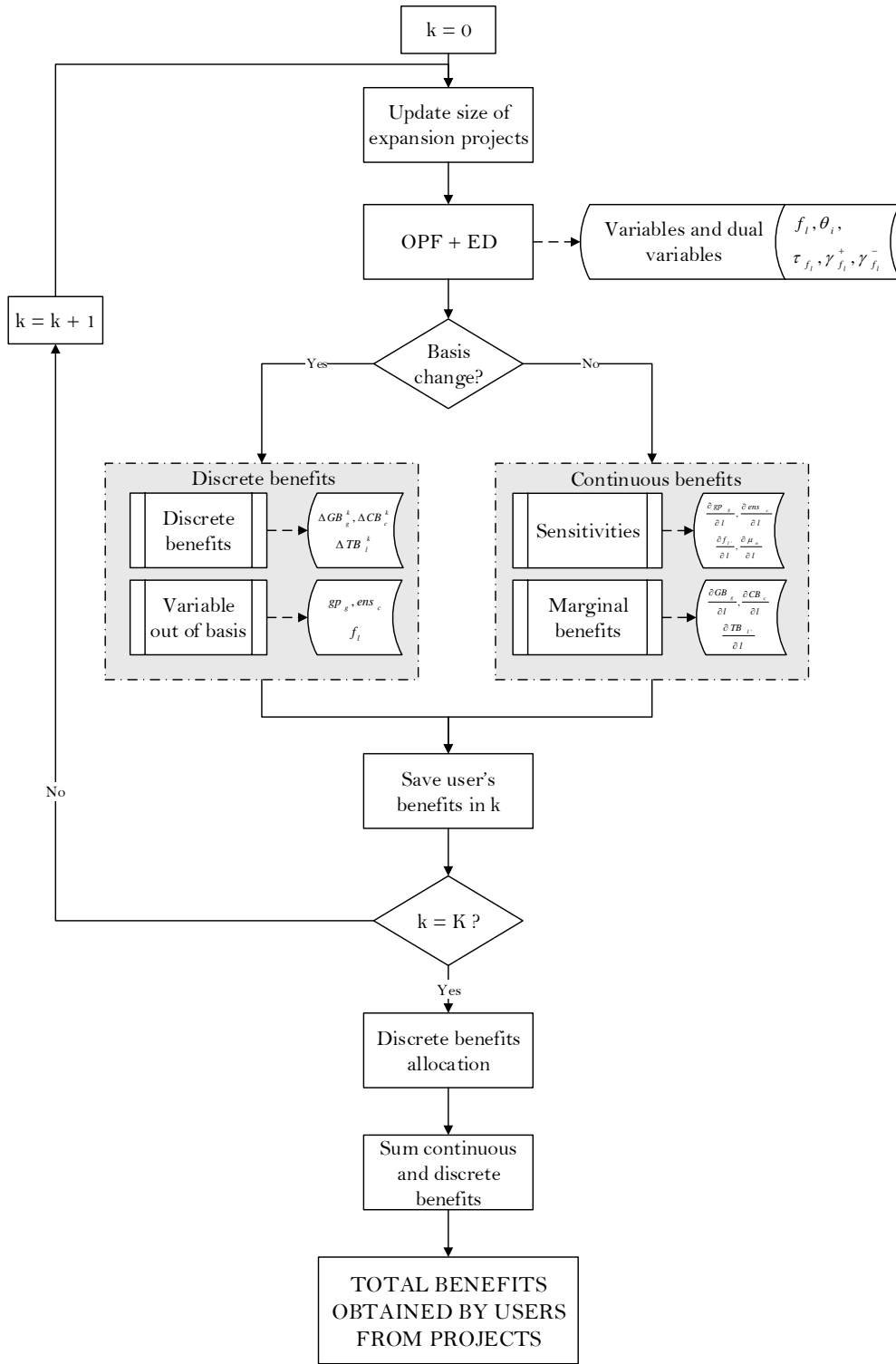

Fig. 3.6. Simplified scheme of application of the proposed method to determine the beneficiaries of individual expansion projects, and the benefits that each network user (beneficiary) obtains from each project, for each time period t considered. All data required to calculate project's beneficiaries is obtained by solving K optimal power flow and economic dispatch problems.

Illustrative example: application of AS to determine the benefits of individual users (beneficiaries) obtained from expansion projects

As previously said, in the small illustrative case example discussed throughout this chapter, the deployment of the expansion projects results in the replacement of the expensive generators (located in node A) with the cheaper units (located in nodes B and C). Fig. 3.7 shows the evolution of the benefits of the whole system, and the slope of this evolution, through the application of the proposed method. As showed in Fig. 3.7, progressively replacing the production of the most expensive generator with the production of cheaper units produces a steep increase in the system benefits (interval 0%-33% in the figure). As soon as the unit A1 stops producing energy⁵⁸, there is a change in the basis of the optimal solution of the dispatch problem, indicated with *1 in Fig. 3.7. This results in a discrete change –reduction– of the energy price in node A (from 50€/MWh to 20€/MWh), as showed in Fig. 3.4 before. After this change in the basis, the ongoing deployment of the expansion plan leads to the progressive substitution of the energy produced by unit A2 with the energy of the units located in nodes B and C, which are cheaper units. Note that, in this second phase of the process of simulation of the gradual deployment of the plan, the increase in system benefits is smaller than in the first one, because the generator unit being replaced is less expensive (interval 33%-67%). Another change in the basis of the dispatch problem – and thus a discrete change in nodal prices– occurs when the production of the unit A2 reaches its minimum capacity, i.e. stops producing, indicated with *2 in Fig. 3.7. From then on, the energy produced by the unit located in node B is progressively replaced by the energy produced by the cheapest generator in the system (unit C). Please note that, again, the increase in system benefits is smaller than before (interval 67%-100%).

⁵⁸ Therefore, the variable production of this unit reaches its lower bound –zero– and goes out of the basis.

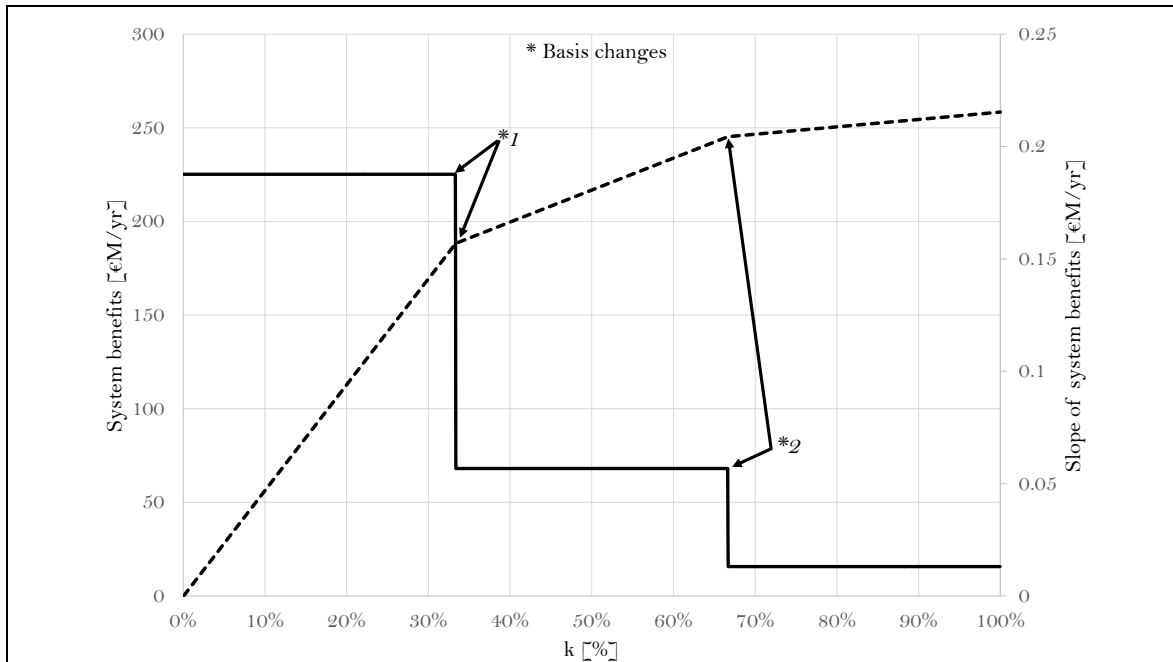

Fig. 3.7. Evolution of the benefits of the whole system (dashed line measured on the left axis) and their rate of change, or slope (continuous line measured on the right axis), throughout all the steps k of application of the AS method (gradual deployment of the plan simulated in AS). Changes in the basis of the problem are indicated with an $*$.

The discrete change in nodal prices occurring when unit A1 stops producing (basis change $*1$ in Fig. 3.7) involves a redistribution of the system benefits among users in this step, as displayed in Fig. 3.8. There is a need to determine the contribution of each expansion project to the discrete changes in benefits, or discrete benefits, obtained by users from this price change. As previously explained, the contribution of each expansion project to the discrete benefits of users is proportional to the contribution of this same project to previous changes in the variable leaving the basis of the problem at the same time this discrete benefit occurs. In this case, the variable leaving the basis is the production of unit A1. As seen in Fig. 3.9, project AB and AC are the ones contributing, though differently, to the reduction of the production of unit A1. Therefore, all the corresponding discrete (changes in the) benefits of users resulting from this change in prices are to be allocated to these projects.

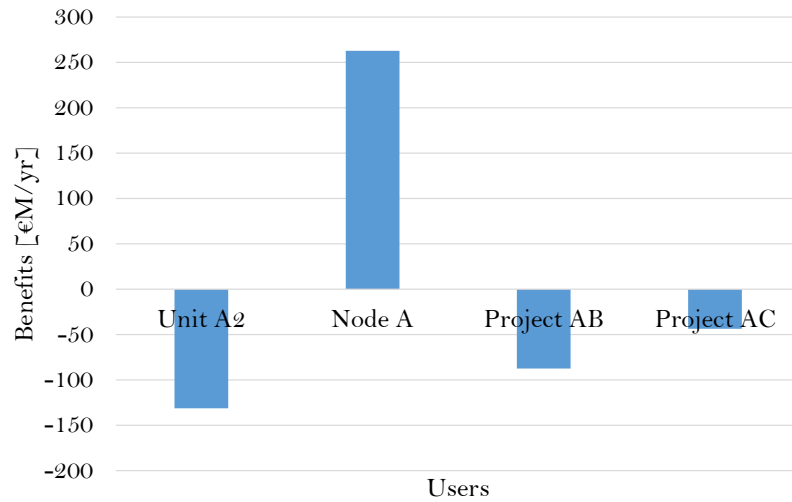

Fig. 3.8. Discrete benefits obtained by users from the change in the problem basis *1. Consumers located in node A are the most favored by this, due to the resulting reduction taking place in the price of this node.

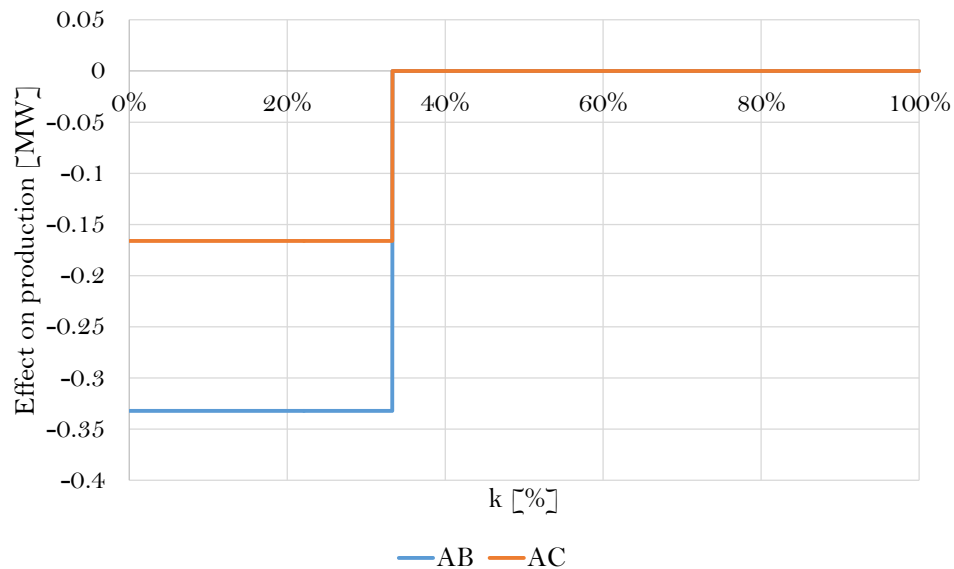

Fig. 3.9. Contribution of each expansion project to the change of the production of unit A1 through all the steps k of the application of the AS method (gradual deployment of the plan simulated in AS).

Finally, the benefits obtained by individual users from expansion projects, indicated in Table 3.2, are computed by adding up the continuous benefits and discrete benefits occurring with the two changes in the basis (*1 and *2) obtained by each network user from each project.

Table 3.2. Dispatch benefits [€M/year] obtained by the users of the power system from each expansion project using the method proposed

Users		AB	AC	Total
Generators	Unit A1	0	0	0
	Unit A2	-66	-66	-131
	Unit B	0	0	0
	Unit C	0	0	0
Consumers	Consumer A	175	175	350
	Consumer B	0	0	0
	Consumer C	0	0	0
Transmission Owners	TO AB	73	-73	0
	TO AC	-36	76	39
Total		146	112	258

The objective of both projects is to connect node A with nodes B and C to replace the production of the expensive generators located in node A with that of the cheaper ones located in nodes B and C. Thus, both expansion projects are benefitting the consumers in node A (to the same extent), and causing negative benefits to the generator unit A2 (also to the same extent). However, they are not providing the same benefits to the different TOs. Each project is, of course, benefitting its owner and reducing the benefits (causing negative benefits) to the owner of the other project. Both projects are causing negative benefits to the owners of the other project because they are helping to reduce the price difference between the nodes connected by those projects. Nonetheless, project AC is causing higher negative benefits to the owner of project AB because it is also causing the power flow between nodes A and B to be lower. Note that, if project AC did not exist (or were not fully deployed), the power flow through the new lines in project AB would be higher, because these lines can accommodate more power. This would not happen the other way around, i.e. if project AB did not exist (or were not fully deployed), the power flow through the new line in project AC would not be higher, because it is already congested.

The approach developed in this thesis to allocate the discrete benefits of network users to expansion projects is necessary in order to calculate correctly the benefits and beneficiaries. In order to illustrate its importance, the proposed method is applied again, but without performing the allocation of the discrete benefits obtained by

network users in the simulated process of gradual deployment of the expansion plan. Table 3.3 indicates the benefits obtained by individual network users from the expansion projects when the discrete benefits are not allocated.

Table 3.3. Dispatch benefits [€M/year] obtained by the users of the power system from each expansion project using AS without the allocation of the discrete benefits of network users

Users		AB	AC	Total
Generators	Unit A1	0	0	0
	Unit A2	0	0	0
	Unit B	0	0	0
	Unit C	0	0	0
Consumers	Consumer A	0	0	0
	Consumer B	0	0	0
	Consumer C	0	0	0
Transmission Owners	TO AB	146	0	146
	TO AC	0	112	112
Total		146	112	258

It is important to see that in this case, without the allocation of the discrete benefits, the total benefits computed are the same as before (€258M/yr), but the total benefits obtained by the network users differ. In fact, only the owners of each project are obtaining benefits, but neither the consumers nor the generators are obtaining benefits. This does not make sense, because now consumers in node A are paying less for the electricity they are consuming (they are obtaining some benefits) and the unit A2 is not selling any electricity (it is obtaining negative benefits). Under this approach consumers are not obtaining any benefit because the change in price occurs in discrete steps (see Fig. 3.4) and the demand (and ENS) does not change. Generators are also affected by the discrete changes in prices. However, contrary to the consumers, its production level changes continuously (see Fig. 3.3). The evolution of the production level does not produce any benefit to the generators because unit A2 is replacing unit A1 as the marginal unit and the price in node A always is equal to the cost of the marginal unit.

3.4 PARTICULARIZATION OF THE AS METHOD TO ESTIMATE THE CONTRIBUTION OF EXPANSION PROJECTS TO OTHER TYPES OF BENEFITS RELATED TO THE OPERATION OF THE POWER SYSTEM

In the previous section, a method to compute the global increase in SW –economic benefits related to the system dispatch– provided by expansion projects and to determine how expansion projects contribute to the benefits obtained by individual network users of the system was proposed. Nonetheless, SW is comprised, as stated in section 3.2, of different cost components, such as the reduction in operational costs, CO₂ emissions or energy not served. These benefits may be considered, or represented, as components of the SW and, then, be measured in economic terms. However, these benefits may also be considered as independent benefits (in accordance with the objectives defined by the authorities). This last option is the approach considered here. Therefore, the objective of this section is to discuss the application of the method proposed to calculate the benefits of each type (components of the SW) produced by each expansion project. Then, I will be able to identify the main function of, or objective pursued by the undertaking of, each expansion project. Thus, benefits related to Security of Supply (SoS), Socio Economic Welfare (referred as SW in this document), RES integration and CO₂ emissions are computed next.

In order to compute the benefits of each type produced by the expansion projects included in the plan, each type of benefit considered in the SW must be considered separately. Using cooperative game jargon, the main concepts of the game to formulate are described next:

- The characteristic function, which is the function of the social benefits resulting from the system dispatch, is here decomposed into the several benefits considered in the SW that may be considered as benefits by themselves: the reduction of CO₂ emissions, the increase of Security of Supply (or reduction in the existing ENS) and the reduction in the production costs of the power system (largely fuel costs). As previously said, another type of benefit can be considered: the increase in the amount of RES generation integrated. Each of these types of benefits corresponds to the function $f(S)$ previously mentioned when introducing the method. Thus, one can assume that the overall characteristic function of the game of allocation of the different types of benefits to expansion projects is divided into many functions, each one representing each type of benefit of the system in the dispatch.
- The players in the game are the expansion projects, which are an input to the method.
- The size of the players is related to the increase in the transmission capacity ($\overline{F}_{l(u)}$), and admittance ($y_{l(ij)}$) of assets affected by the deployment of the expansion projects.

- The great coalition is the expansion plan decided at the network expansion planning stage.

The solution of this cooperative game involves, formally speaking, the allocation of the different types of benefits produced by the deployment of the expansion plan to the projects within the plan. Considering the mathematical formulation introduced in section 3.2.3, the types of benefits in the dispatch just mentioned could be easily defined:

- a. The level of Security of Supply is measured in terms of the amount of energy not served in the system, which is computed as the sum of the energy not served of all the consumers in the network, (3.41). Thus, this benefit is associated with the reduction in the energy not served.
- b. The level of compliance with environmental objectives, or those on the level of emissions, is measured in terms of the total CO₂ emissions produced in the system dispatch, which can be calculated as the sum of the CO₂ emitted by generators when producing the energy sold in the market, (3.42). Thus, this benefit is associated with the reduction in emissions.
- c. The amount of RES energy integrated in the system is the sum of the energy produced by all the RES generators, (3.43). Thus, this benefit is associated with the increase in RES energy produced.

Security of Supply and RES integration benefits can be expressed in energy units (MWh or GWh), while the benefits resulting from the reduction of CO₂ emissions can be expressed in MtCO₂.

$$SoSB^t = \sum_c ens_c^t \quad (3.41)$$

$$CO2B^t = \sum_g ECO2_g \cdot gp_g^t \quad (3.42)$$

$$RESB^t = \sum_{g \in res} gp_g^t \quad (3.43)$$

As stated in section 3.2.4, the numerical computation of the integral in (3.1) for each type of benefit can be carried out by discretizing the variation of the single integration parameter λ_l in K values, or subintervals, in the interval $[0,1]$ ⁵⁹. The marginal increase in the several benefit functions with respect to the size of expansion projects is computed by deriving (3.41)-(3.43) with respect to the size of each project, and its expression is provided in (3.44)-(3.46).

$$\left(\frac{\partial SoSB}{\partial l} \right)_t = \sum_c \left(\frac{\partial ens_c}{\partial l} \right)_t \quad (3.44)$$

⁵⁹ Please see footnote 47 for details about the accuracy of this numerical integration.

$$\left(\frac{\partial CO2B}{\partial l}\right)_t = \sum_g ECO2_g \cdot \left(\frac{\partial gp_g}{\partial l}\right)_t \quad (3.45)$$

$$\left(\frac{\partial RESB}{\partial l}\right)_t = \sum_{g \in res} \left(\frac{\partial gp_g}{\partial l}\right)_t \quad (3.46)$$

where $\left(\frac{\partial gp_g}{\partial l}\right)_t$, $\left(\frac{\partial ens_c}{\partial l}\right)_t$ are the marginal increases (positive or negative) taking place in the production of unit g and the ENS of consumer c , respectively, in each time period t , when there is a marginal increase in the size of asset l due the deployment of an elemental expansion project⁶⁰.

Using the discretized version of (3.1) for each time period t , the increases in each type of benefit, in each discrete step k of the AS algorithm (simulated process of gradual deployment of the expansion plan) are calculated according to (3.47)-(3.49).

$$\Delta SoSB_k^{l,t} = \left(\frac{\partial SoSB}{\partial l}\right)_{t,k} \Delta l_k \quad (3.47)$$

$$\Delta CO2B_k^{l,t} = \left(\frac{\partial CO2B}{\partial l}\right)_{t,k} \Delta l_k \quad (3.48)$$

$$\Delta RESB_k^{l,t} = \left(\frac{\partial RESB}{\partial l}\right)_{t,k} \Delta l_k \quad (3.49)$$

These benefits are computed for each step increase Δl_k in the size of asset l affected by the deployment of the elemental expansion projects within the plan. Then, the contribution of each expansion project to the benefits of each kind, for each time period t , are computed as the sum of the benefits corresponding to all the steps k considered in the simulated process of gradual deployment of the expansion plan when applying the AS algorithm, see (3.50)-(3.52).

$$SoSB^{l,t} = \sum_k \Delta SoSB_k^{l,t} \quad (3.50)$$

$$CO2B^{l,t} = \sum_k \Delta CO2B_k^{l,t} \quad (3.51)$$

$$RESB^{l,t} = \sum_k \Delta RESB_k^{l,t} \quad (3.52)$$

As in the previous section, the total benefits of each kind produced by an expansion project are computed as the sum of the benefits of this project corresponding to all the time periods t considered multiplied by their weight (or duration), W_t , as in (3.53)-(3.55).

$$SoSB^l = \sum_t W_t \cdot SoSB^{l,t} \quad (3.53)$$

⁶⁰ For more details about the calculation of these marginal increases or sensitivities, the reader is referred to Appendix A.

$$CO2B^l = \sum_t W_t \cdot CO2B^{l,t} \quad (3.54)$$

$$RESB^l = \sum_t W_t \cdot RESB^{l,t} \quad (3.55)$$

The diagram in Fig. 3.10 illustrates the process of application of the proposed method. As in the previous sections, I solve K optimal power flow and economic dispatch problems corresponding to the K steps taken in the implementation of the AS algorithm (simulated process of deployment of the plan). For each problem k , I solve the ED and OPF problems and, then, compute the sensitivities of the production of generation units and the ENS of consumers, respectively, with respect to the size of asset l . These sensitivities are used to compute the marginal benefits of different types resulting from the marginal deployment of projects in the plan in each step. These benefits are saved in each iteration. Finally, I calculate the contribution of each expansion project to the different types of benefits provided by the expansion plan by summing the marginal benefits in the K steps.

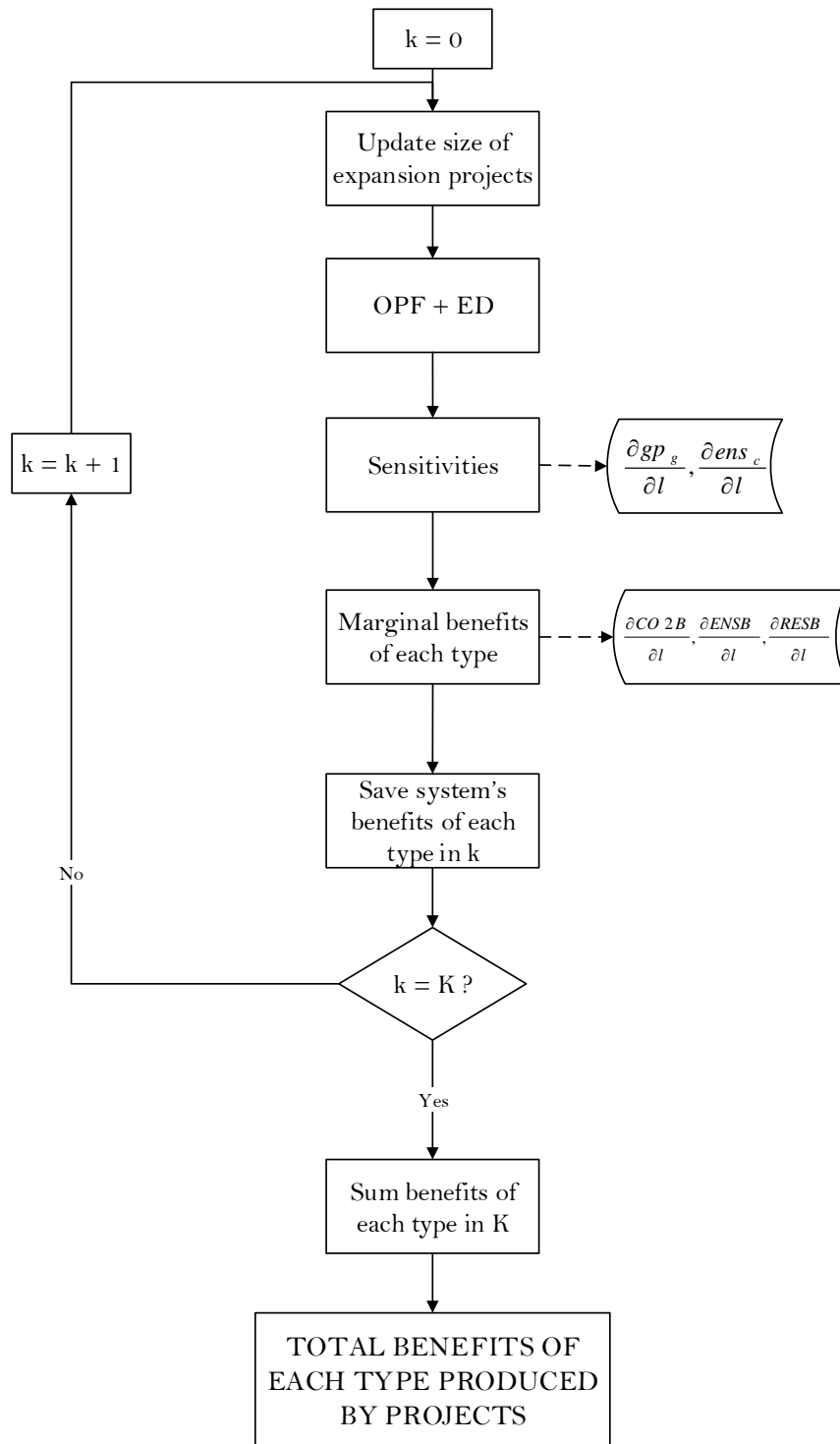

Fig. 3.10. Simplified scheme of application of the proposed method to determine the amount of benefits of several types produced by individual expansion projects for each time period t considered. All data required to calculate project's benefits –of the different types of them– is obtained by solving K optimal power flow and economic dispatch problems.

Illustrative example: application of AS to determine the contribution of expansion projects to the different types of benefits considered

Let us consider the same case example that have been used throughout this chapter to illustrate the application of AS. Let us assume that units A1, A2 and B are thermal units and unit C is a wind generator. The CO₂ emission rate of units A1 and A2 is 0.575tCO₂/MWh, while the rate of unit B is 0.375tCO₂/MWh. Unit C does not produce CO₂ emissions.

The contribution of the different expansion projects to the reduction of CO₂ emissions and to the integration of RES generation in each of the K steps of the process of deployment of the expansion plan is displayed in Fig. 3.11. The system does not have any energy not supplied originally. Then, the security of supply cannot be improved. Consequently, there is no contribution to security of supply that can be achieved by expansion projects.

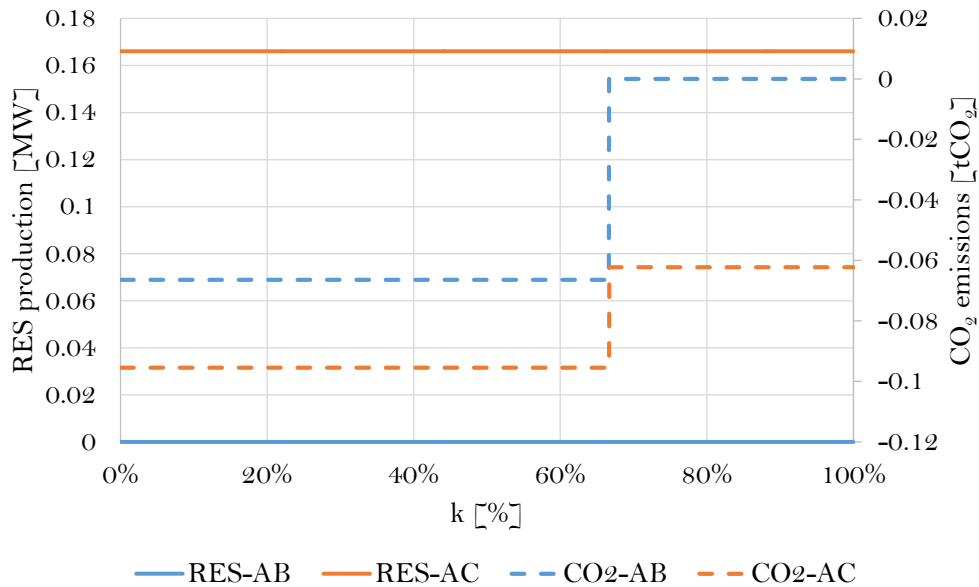

Fig. 3.11. Contribution of each expansion project to the integration of RES generation (continuous lines and left axis) and the reduction of CO₂ emissions (dashed lines and right axis) through all the steps k of the application of the AS algorithm (gradual deployment of the plan).

Finally, the total contribution of the expansion projects can be computed. Expansion projects AB and AC cause a reduction of CO₂ emissions of 1,167ktCO₂ and 2,226ktCO₂, respectively. Project AC is the only one contributing to the integration of additional RES generation. This is an intuitive result, because project AC is the

one connecting the wind generator, which is located in node C, to the rest of the system.

3.5 COMPLYING WITH THE REQUIREMENTS OF A SOUND ANALYSIS OF THE BENEFITS OF PROJECTS: ASSESSMENT OF THE AUMANN-SHAPLEY METHOD

This section evaluates the method proposed in the light of the properties discussed in Chapter 2 that a sound analysis of the benefits of projects should comply with. Analogously to what has been done in that chapter, the compliance of the AS method with each of these characteristics is analyzed using the same case example that has been considered throughout this chapter.

3.5.1 Benefits should take into account interactions among expansion projects

The method proposed considers all possible orders of deployment of expansion projects. In fact, it considers all possible orders of deployment of the elemental expansion projects that comprise the discrete expansion projects. Therefore, the method is able to take into account that some benefits may be provided by several projects (alternative projects) and that some other benefits require the deployment of several other projects (complementary projects) in order to be realized.

Illustrative example

The results obtained with the methods so far analyzed (PINT, TOOT and Shapley) are compared with the results calculated with the method proposed in this section (AS). The distribution of benefits among projects using each method is indicated in Table 3.4.

Table 3.4. Dispatch benefits [€M/year] of the expansion projects computed using the several methods reviewed and the AS method proposed

Project	AS	PINT	TOOT	Shapley
AB	146	219	44	131
AC	112	214	39	127
Total	258	433	83	258

Note that the method here proposed is able to provide projects benefits that add up to the total benefits actually produced by the whole plan (€258M/year), while PINT and TOOT do not.

3.5.2 Benefits should not depend on the order of deployment of projects in the plan (or assume a specific order)

As just said, benefits computed using the method proposed do not result from considering, or assuming, any specific order, because all orders are considered.

3.5.3 Benefits assigned to projects are a function of the changes these, and other projects in the plan, produce in the network, and not of how the investments are clustered into projects

Thanks to the use of the artifact of elemental expansion projects, the method proposed is able to fulfill this characteristic. As explained in the previous chapter, this characteristic has several implications that will be analyzed, and explained, separately:

a) Benefits assigned to projects should add up to the total benefits of the plan or group of projects considered: the project benefit function should be additive

Cooperative game theory allocates a characteristic function among the players of the game. Therefore, the method proposed, which is based on a cooperative game solution concept, guarantees that the benefits estimated for expansion projects add up to the total benefits of the plan.

Illustrative example

As indicated when analyzing the interactions among projects, the AS approach computes project benefits that amount to the total benefits actually produced by the expansion plan as a whole (€258M/year).

b) Benefits assigned to each project should be independent of the rest of projects that the plan is divided into

The method proposed computes the benefits produced by each of the elemental projects that make the several projects defined in the plan. The benefits produced by each elemental project depend on the level of deployment of the plan, or development achieved

by each network element, i.e. on the reinforcements made to the network, but not on which specific projects have been carried out, or, in other words, how these reinforcements that are deemed to have already been deployed have been grouped into projects. Hence, the benefits computed for each project are independent on how the rest of projects are defined.

Illustrative example

Again (as in the previous chapter), one may consider now a different set of projects: each line is now a stand-alone project. Thus, I have projects AB1, AB2 and AC. Their benefits as resulting from all the methodologies are gathered in Table 3.5.

Table 3.5. Dispatch benefits [€M/year] of the expansion projects computed using the several approaches reviewed and the AS method proposed when projects AB1 and AB2 are considered

Project	AS	PINT	TOOT	Shapley
AB1	73	175	0	73
AB2	73	175	0	73
AC	112	215	39	112
Total	258	565	39	258

The reader should note that the definition of projects AB1 and AB2 instead of project AB does not affect the benefits allocated to project AC with the method proposed (please, compare Table 3.4 and Table 3.5). Remember that this is not the case when using the Shapley method (please, compare Table 2.4 and Table 2.5).

c) The benefits assigned to any elemental project, or investment, shall not depend on the size of the project it belongs to: comparability or isonomy requirement

The method proposed is based on computing the benefits of real (discrete) expansion projects as the sum of the benefits produced by elemental ones. Thanks to this approach, one can compute the benefits produced by any project as the average ones produced by a unit increase in the size of the network elements affected by this project times the size of the project. Then, no matter what the size of the discrete project is, the benefits assigned to this project per unit of size of it shall always be the same.

Illustrative example

When considering whatever two separate projects for the expansion of the corridor AB, AB1 and AB2, or a single project AB, instead, the value of these projects computed according to AS is based on computing the average value of an elemental project making the former. This means that the elemental projects comprising projects AB1 and AB2, and the original project AB are always assigned the same value, regardless of which discrete projects are defined, i.e. the benefit provided by these projects per unit of size is always deemed to be the same. Thus, the different size of each project (projects AB1 and AB2 have a size of 500MW each, while project AB has a size of 1,000MW) is not affecting the estimation of its benefits per unit of it. As a result, the proposed method provides benefits for projects AB1 and AB2 that add up to the benefits of the original project AB (€146M/yr).

Please, note that this result is also related to point a) previously discussed.

3.5.4 The benefit assessment method should be applicable to real-life systems and large expansion plans

Thanks to the law of large numbers, the AS method can be applied very efficiently (computationally speaking), because it allows not to consider all the orders of deployment of the elemental expansion projects, which would be, in any case, impossible. The implementation of this method allows computing the benefits and beneficiaries of expansion projects considering a reasonable number of K steps in the process. It is important to remark that the number of K steps considered would be, approximately, the same for small and large power systems –and expansion plans–. Therefore, the number of economic dispatch problems and optimal power flows to solve (K) would also be, approximately, the same.

Illustrative example

The considered case example does not allow to demonstrate that the AS method can be applied to large cases (a bigger case study will be provided in Chapter 4). However, it is important to remark that the same number of economic dispatch problems are to be solved when only projects AB and AC are considered as when the projects considered are AB1, AB2 and AC.

3.5.5 The benefit assessment methodology should be easy to understand

I have to acknowledge that the method proposed here is not fully intuitive. The use of elemental expansion projects is not an easy concept to understand. Besides, the method itself can be deemed sophisticated somehow. However, it has been shown that the implementation proposed for the method has a clear interpretation: it simulates the gradual deployment of the expansion plan and compute the average value of each elemental project over it to determine the aggregate value of each discrete project comprised by the former.

Illustrative example

Note that during the application of the method to the considered case example one is able to understand what the effects of the deployment of the expansion plan (and its elemental projects) are.

3.6 CONCLUSIONS

In this chapter, I have proposed a method to determine the benefits produced in the dispatch by the expansion projects within a plan. The proposed method relies on the idea that **projects within an expansion plan should be assessed together** with the other expansion projects in the plan, and not on an individual basis. Therefore, we make use of cooperative game theory for this, and, within it, of the **Aumann-Shapley concept**.

The Aumann-Shapley game formulated considers that **expansion projects are the players of the game**, and the function to be allocated are either the benefits of the system, or the benefits of individual users or groups of users of the network. I have focused on allocating the several types of benefits that can be considered in the dispatch. The proposed method is, then, particularized to address each objective pursued: computing the benefits, beneficiaries, or contribution to the different benefits of expansion projects.

Finally, I have to remark that the method proposed features **most of the desirable characteristics of a benefit allocation method described** in the previous chapter, which makes it coherent with the technical and economic principles ruling the expansion of the network. These characteristics include: a) the fact that the benefits computed take interactions of expansion projects into account; b) the ability not to assume a specific order of deployment of projects, which involves that the benefits computed do not depend on the order of deployment of the projects; c) the independence of the benefits assigned to

expansion projects of how the rest of investments in the expansion plan are grouped into other projects; and d) the fact that it is applicable to real-life systems. On the other hand, although it is not completely intuitive or easy to understand, its implementation has a clear interpretation.

Chapter 4

Case studies

In the previous chapter, a proposal for a benefit analysis methodology of expansion projects within a plan, or group of projects, has been presented. There, a simple case example is employed in order to illustrate the application of the method proposed and its characteristics. This new chapter includes several case studies, of different sizes, in order to show, in more detail, the results provided by the method, as well as its applications related to the transmission expansion planning and the regulation of the electricity transmission activity.

4.1 INTRODUCTION

The previous chapters have reviewed in detail the existing methodologies to determine the benefits and beneficiaries of expansion projects (Chapter 2), discuss at length the properties of a sound benefit assessment method (also in chapter 2) and propose a method to perform this assessment (Chapter 3). In these chapters, the reviews, discussions and proposals are illustrated by way of a very simple, illustrative, case example.

Nevertheless, the case example employed in those chapters is not able to demonstrate the applicability of the proposed method to support the planning of the expansion of the transmission grid and the regulation of the transmission activity, including, largely, the allocation of the cost of transmission assets. Hence, in this chapter I provide two case studies that I employ to illustrate the possible applications of the proposed method related to the aforementioned topics. Next, both case studies are described briefly:

- 9-bus power system. Although this case study is not of a large size, it allows to consider several network users and expansion projects that the former are benefiting from. This case is used to show, in more detail, the range of results that can be provided by the proposed method and their possible uses, as well as to highlight the drawbacks (and inconsistencies) of the existing methods when applied to support the planning of the expansion of the transmission grid and as a tool to guide some aspects of the regulation of electricity transmission.
- 118-bus power system. This second case study is used to prove the applicability of the proposed method to large-scale systems and transmission expansion plans. Thus, the proposed method is here applied to, i) rank expansion projects based on their benefits and select the ones that should be undertaken with the highest priority; ii) understand the objective, or main function, of each of the expansion projects selected as most relevant; and iii) apply the “beneficiary pays” principle in order to allocate the costs of these expansion projects to network users based on an estimate produced by the proposed benefit assessment method of the amount of benefits that each network user in the system, including generators, consumers, and owners of each transmission facility, is expected to obtain from each of the selected expansion projects. The analysis on the allocation of the cost of transmission projects based on the benefits that individual users, or groups of them, shall obtain from these projects is carried out taking as a reference the estimates of benefits produced by the benefit assessment method proposed in this work. These benefits are assumed to be representative of the actual ones obtained by network users, or groups of them, from projects, as well as of the estimates that these same network users, or groups of them, are making of the benefits they are

obtaining. This makes sense once we have argued that only the benefits computed using this method are sensible and representative of the real ones obtained by network users. Several possible cost allocation arrangements regarding the consideration made in them of the negative benefits obtained by groups of users from the projects to undertake are compared. This allows to draw some conclusions on which arrangement is most likely to achieve the construction of these projects.

4.2 CASE STUDY: 9-BUS POWER SYSTEM

The 9-bus power system represented in Fig. 4.1 is considered here to illustrate the application of the method proposed in this thesis. This case study, although not being a large power system, allows us to consider several network users and expansion projects, and clearly interpret the results obtained and compare them to those produced by the several methods already applied in the literature.

The data for this 9-bus system have been mainly drawn from (Rivier et al. 2013). However, the system considered there has been modified to be able to compute the benefits obtained by network users from transmission expansion projects in a context, like the foreseeable one in many real power systems, where there are large amounts of new clean generation of low variable costs (like RES) and a significant increase in the demand takes place due to the partial electrification of the transport system and other energy uses. The resulting TEP (see Table 4.1) comprises 12 reinforcements, or new lines, (two new lines, or circuits, for each corridor reinforced). Each of these new lines built is considered a separate project, and all of them are scheduled to be installed in the same time period. The main objective of the TEP is to connect the new RES generation (located in nodes 2 and 8) to the rest of the system and to avoid the ENS that would otherwise exist (in nodes 7 and 9). The generation and demand data are provided in Table 4.2, where new RES generation corresponds to that owned by Firm 2 and Firm 1 in nodes 2 and 8, respectively. The transmission data are provided in Table 4.1. For the sake of simplicity, only one operation situation is considered. Then, this operation situation is assumed to represent the operation of the power system over the 8,760 hours of the target year in the planning horizon. All the transmission reinforcements are new AC lines (circuits). As aforementioned, each of them is considered as a stand-alone project. When applying the method proposed⁶¹, a linear relationship is assumed to exist between the transmission capacity and admittance of the expansion projects in the plan ($y_{l(ij)} = \alpha \overline{F_{l(ij)}}$), since all of

⁶¹ The execution time of the proposed method in this case study was about 300 seconds.

these projects are full AC lines. However, other options for the relationship between the capacity and admittance of each asset affected by the plan could have been considered.

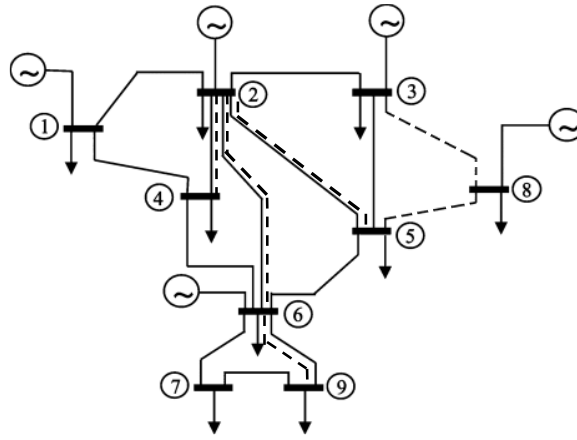

Fig. 4.1. 9-Bus power system schematic representation. The original network is depicted in continuous lines, while the new projects to be installed are depicted in dashed lines.

Table 4.1. Network data for the 9-Bus system

Line	Reactance	Capacity
	[p.u.]	[MW]
1-2	0.058	500.0
1-4	0.040	500.0
2-3	0.034	500.0
2-4	0.080	50.0
2-5	0.040	50.0
2-6	0.080	50.0
3-5	0.020	500.0
4-6	0.120	500.0
5-6	0.040	500.0
6-7	0.600	100.0
6-9	0.400	50.0
7-9	0.040	500.0
New transmission lines (TEP)		
2-4 (1,2)	0.040	500.0
2-5 (1,2)	0.040	500.0
2-6 (1,2)	0.080	250.0
3-8 (1,2)	0.160	250.0
5-8 (1,2)	0.160	250.0
6-9 (1,2)	0.080	500.0

Table 4.2. Generation and demand data for the 9-bus system

Node	Generation								Load	
	Firm 1 (F1)		Firm 2 (F2)		Firm 3 (F3)		Firm 4 (F4)		Demand	ENS
	Capacity	Cost	Capacity	Cost	Capacity	Cost	Capacity	Cost		Cost
	[MW]	[€/MWh]	[MW]	[€/MWh]	[MW]	[€/MWh]	[MW]	[€/MWh]	[MW]	[€/MWh]
1	600	30	150	65	250	70	200	75	1	1,500
2	200	59	1,000	10	100	74	-	-	480	1,500
3	320	30	200	61	100	76	100	80	80	1,500
4	-	-	-	-	-	-	-	-	320	1,500
5	-	-	-	-	-	-	-	-	480	1,500
6	400	30	-	-	-	-	-	-	160	1,500
7	-	-	-	-	-	-	-	-	200	1,500
8	200	15	-	-	-	-	-	-	30	1,500
9	-	-	-	-	-	-	-	-	200	1,500

4.2.1 Optimal dispatch of the power system

The optimal dispatch of the system for the considered operation situation, both without and with the TEP in place, is provided in Table 4.3. The economic dispatch is provided in this table as the amount of power produced by each firm in each node both without the expansion plan in place (left hand value of power production for each node and firm) and with it in place (right hand value). Besides, on the right hand column of the table, the amount of ENS in each node is provided both without the expansion plan in place (left hand value) and with the plan in operation (right hand one). The deployment of the TEP results in an increase of the SW of €4,225M/year, and the distribution of the benefits produced by the plan, as a whole, among network users is provided in Table 4.4 and Table 4.5. The benefit obtained by each user from the TEP is computed as the difference between the market (operation) benefits gained by this user (calculated according to equations (3.21)-(3.23) of Chapter 3)⁶² with and without the expansion plan in place. In Table 4.4 the annual energy market benefits obtained by each generation company and the load in each node are provided in €M/year. In Table 4.5, the annual energy market benefits obtained by the owner of each transmission facility from the expansion plan are provided. These benefits are also expressed in €M/year⁶³.

Table 4.3. Economic dispatch without/with the transmission expansion plan in place

Node	Price	Output				ENS
		F1	F2	F3	F4	
	[€/MWh]	[MW]	[MW]	[MW]	[MW]	[MW]
1	30/30	310/42	0/0	0/0	0/0	0/0
2	10/10	0/0	333/945	44/0	-	0/0
3	76/61	320/320	200/44	0/0	0/0	0/0
4	44/44	-	-	-	-	0/0

⁶² Remember that a nodal pricing scheme is assumed to be applied in all the case studies in this chapter. In addition, the benefit that consumers obtain from the electricity they consume is assumed here to be equal to the cost of the ENS. The cost of ENS considered here is 1,500€/MWh (see Table 4.2).

⁶³ Please note that the increase in the SW produced by the expansion plan, and the benefits obtained by the users of the network from this plan and the individual reinforcements in it, are dependent on the cost assigned to the ENS (and the value considered for the benefit that the consumers obtain from consuming electricity). In this case, the benefits obtained by consumers located in nodes 7 and 9, and TOs 6-7, 6-9 and 7-9 would change when considering a different cost for the ENS.

5	115/88	-	-	-	-	0/0
6	73/41	400/400	-	-	-	0/0
7	1,500/41	-	-	-	-	113/0
8	15/74	30/200	-	-	-	0/0
9	1,595/41	0/0	-	-	-	200/0

Table 4.4. Benefit [€M/yr] obtained by each generator and consumer from the TEP

Node	Generators				Load
	F1	F2	F3	F4	
1	0	0	0	0	0
2	0	0	0	-	0
3	-42	-26	0	0	11
4	-	-	-	-	0
5	-	-	-	-	114
6	-112	-	-	-	45
7	-	-	-	-	2,555
8	104	-	-	-	-16
9	-	-	-	-	2,555

Table 4.5. Benefit [€M/yr] obtained by each TO from the TEP

TOs	Benefit
1-2	19
1-4	-19
2-3	43
2-4	0
2-5	-12
2-6	22
3-5	-58
4-6	12
5-6	-47

6-7	-458
6-9	-667
7-9	42
2-4 (1,2)	30/30
2-5 (1,2)	34/34
2-6 (1,2)	12/12
3-8 (1,2)	-3/-3
5-8 (1,2)	7/7
6-9 (1,2)	0/0

The increase in SW produced by the deployment of the TEP comes from the reduction in the ENS (that of consumers located in nodes 7 and 9) and from the reduction in the operational costs of the system that the network reinforcements in the plan achieve. The RES units located in nodes 2 and 8 increase their production with the expansion of the network, and replace the production with expensive generators.

The main beneficiaries from the deployment of the TEP are the consumers of the system, who are having a reduction in the energy price they pay. Among the whole set of consumers, the ones that are obtaining the highest benefits are the consumers located in nodes 7 and 9 (see Table 4.4) due to the avoidance of the ENS they were incurring⁶⁴. However, as it is normal with the expansion of the network, not all the network users are benefiting from it. Consumers located in node 8 are obtaining negative benefits (being harmed) by the deployment of the TEP, because their energy price is increased. Before the TEP is deployed, these consumers are the only ones consuming the energy from the unit located in node 8, which is one of the cheapest. However, after the TEP is deployed, this node is connected to the rest of the network. Then, the production from this unit is also available for the rest of the consumers, causing that the price in node 8 increases.

The generators as a whole are obtaining negative benefits from the deployment of the TEP, because the energy price in most nodes of the network generally, decreases. Moreover, some of the generation units also see their production reduced. However, the generation unit located in node 8 is obtaining positive benefits from the plan, since, as a result of its deployment, this generator increases its production and the price in its node also increases.

⁶⁴ Remember that this result is dependent on the cost assigned to the ENS.

4.2.2 Estimating the benefits of expansion projects using the different methods discussed

As pointed out in Chapter 2, one of the main drawbacks of the Shapley value method is that it is, computationally speaking, very demanding. Therefore, its application is very difficult, or even intractable, for expansion plans of a real-life size, comprising more than a handful of projects. This is the case here. Note that, although this case study is not big, applying the method based on the Shapley value to determine the benefits and beneficiaries of expansion projects would require considering $12!$ (more than $4.7 \cdot 10^8$) deployment orders of the expansion projects, given that the plan comprises 12 expansion projects. Hence, this method cannot be applied here.

The benefits of expansion projects obtained by each network user in the system from each expansion project for each of the rest of benefit assessment methods previously reviewed in this thesis project (the PINT and TOOT ones described and assessed in Chapter 2), as well as those produced by the method proposed (AS), are shown in Table 4.6 to Table 4.8, for those benefits earned by consumers, Table 4.9 to Table 4.11, for those benefits earned by each generator in each node, and Table 4.12, for the benefits earned by TOs when the AS method is applied. Benefits obtained by TOs according to the TOOT and PINT methods are zero in this case, though this may not be the case in other cases. Benefits are expressed in €M/year of operation of the system in the target horizon. In each row of each table, the benefits obtained by the corresponding network user from each of the several projects are provided in a separate column. As the reader may notice (and as have been explained in chapters 2 and 3), the benefits deemed to be obtained by network users from projects largely depend on the benefit assessment method applied to compute them.

Table 4.6. Benefits [€M/yr] obtained by consumers from each TEP project using the AS approach

Consumer (node)	Project						Total
	2-4 (1,2)	2-5 (1,2)	2-6 (1,2)	3-8 (1,2)	5-8 (1,2)	6-9 (1,2)	
1	0.0/0.0	0.0/0.0	0.0/0.0	0.0/0.0	0.0/0.0	0.0/0.0	0.0
2	0.0/0.0	0.0/0.0	0.0/0.0	0.0/0.0	0.0/0.0	0.0/0.0	0.0
3	0.0/0.0	0.4/0.4	-0.1/-0.1	2.1/2.1	4.0/4.0	-1.2/-1.2	10.5
4	0.0/0.0	0.0/0.0	0.0/0.0	0.0/0.0	0.0/0.0	0.0/0.0	0.0
5	0.0/0.0	3.9/3.9	-1.3/-1.3	20.9/20.9	44.8/44.8	-11.1/-11.1	114.2
6	0.0/0.0	0.7/0.7	12.3/12.3	3.6/3.6	7.8/7.8	-2.0/-2.0	44.8
7	0.0/0.0	0.0/0.0	4.8/4.8	0.2/0.2	0.2/0.2	1,272.5/1,272.5	2,555.5
8	0.0/0.0	0.0/0.0	0.0/0.0	-1.9/-1.9	-5.9/-5.9	0.0/0.0	-15.6

9	0.0/0.0	0.0/0.0	4.4/4.4	0.2/0.2	0.2/0.2	1,273.0/1,273.0	2,555.5
Total	0.0/0.0	5.0/5.0	20.1/20.1	25.0/25.0	51.1/51.1	2,531.2/2,531.2	

Table 4.7. Benefits [€M/yr] obtained by consumers from each TEP project using the PINT approach

Consumer (node)	Project						Total
	2-4 (1,2)	2-5 (1,2)	2-6 (1,2)	3-8 (1,2)	5-8 (1,2)	6-9 (1,2)	
1	0.0/0.0	0.0/0.0	0.0/0.0	0.0/0.0	0.0/0.0	-0.4/-0.4	-0.7
2	0.0/0.0	0.0/0.0	0.0/0.0	0.0/0.0	0.0/0.0	42.1/42.1	84.2
3	0.0/0.0	10.5/10.5	0.0/0.0	10.5/10.5	32.2/32.2	-608.6/-608.6	-1,110.7
4	0.0/0.0	0.0/0.0	0.0/0.0	0.0/0.0	0.0/0.0	-208.8/-208.8	-417.6
5	0.0/0.0	100.2/100.2	0.0/0.0	100.2	307.2/307.2	-5,824.4/-5,824.4	-10,633.7
6	0.0/0.0	18.2/18.2	19.0/19.0	18.2/18.2	55.9/55.9	-1,074.1/-1,074.1	-1,925.7
7	0.0/0.0	0.0/0.0	0.0/0.0	0.0/0.0	0.0/0.0	72.3/72.3	144.6
8	0.0/0.0	0.0/0.0	0.0/0.0	-12.1/-12.1	-7.0/-7.0	0.0/0.0	-38.2
9	0.0/0.0	0.0/0.0	0.0/0.0	0.0/0.0	0.0/0.0	0.0/0.0	0.0
Total	0.0/0.0	128.9/128.9	19.0/19.0	116.8/116.8	388.3/388.3	-7,601.9/-7,601.9	

Table 4.8. Benefits [€M/yr] obtained by consumers from each TEP project using the TOOT approach

Consumer (node)	Project						Total
	2-4 (1,2)	2-5 (1,2)	2-6 (1,2)	3-8 (1,2)	5-8 (1,2)	6-9 (1,2)	
1	0.0/0.0	0.0/0.0	0.0/0.0	0.0/0.0	0.0/0.0	0.0/0.0	0.0
2	0.0/0.0	0.0/0.0	0.0/0.0	0.0/0.0	0.0/0.0	0.0/0.0	0.0
3	0.0/0.0	0.0/0.0	0.0/0.0	0.0/0.0	0.0/0.0	0.0/0.0	0.0
4	0.0/0.0	0.0/0.0	0.0/0.0	0.0/0.0	0.0/0.0	0.0/0.0	0.0
5	0.0/0.0	0.0/0.0	0.0/0.0	4.3/4.3	4.3/4.3	0.0/0.0	17.3
6	0.0/0.0	0.0/0.0	416.6/416.6	0.5/0.5	0.5/0.5	0.0/0.0	835.2
7	0.0/0.0	0.0/0.0	520.8/520.8	0.6/0.6	0.6/0.6	2,395.8/2,395.8	5,835.6
8	0.0/0.0	0.0/0.0	0.0/0.0	1.3/1.3	-1.1/-1.1	0.0/0.0	0.5
9	0.0/0.0	0.0/0.0	520.8/520.8	0.6/0.6	0.6/0.6	2,555.5/2,395.8	6,155.0
Total	0.0/0.0	0.0/0.0	1,458.1/1,458.1	7.4/7.4	5.0/5.0	4,951.3/4,951.3	

Table 4.9. Benefits [€M/yr] obtained by generators from each TEP project using the AS approach

Firm-Node	Project						Total
	2-4 (1,2)	2-5 (1,2)	2-6 (1,2)	3-8 (1,2)	5-8 (1,2)	6-9 (1,2)	
F1-Nd1	0.0/0.0	0.0/0.0	0.0/0.0	0.0/0.0	0.0/0.0	0.0/0.0	0.0
F1-Nd2	0.0/0.0	0.0/0.0	0.0/0.0	0.0/0.0	0.0/0.0	0.0/0.0	0.0
F1-Nd3	0.0/0.0	-1.6/-1.6	0.5/0.5	-8.4/-8.4	-16.1/-16.1	4.6/4.6	-42.0
F1-Nd6	0.0/0.0	-1.7/-1.7	-30.7/-30.7	-8.9/-8.9	-19.5/-19.5	4.9/4.9	-111.9
F1-Nd8	0.0/0.0	0.1/0.1	0.0/0.0	13.0/13.0	39.1/39.1	-0.2/-0.2	104.0
F2-Nd1	0.0/0.0	0.0/0.0	0.0/0.0	0.0/0.0	0.0/0.0	0.0/0.0	0.0
F2-Nd2	0.0/0.0	0.0/0.0	0.0/0.0	0.0/0.0	0.0/0.0	0.0/0.0	0.0
F2-Nd3	0.0/0.0	-1.0/-1.0	0.3/0.3	-5.3/-5.3	-10.1/-10.1	2.9/2.9	-26.3
F3-Nd1	0.0/0.0	0.0/0.0	0.0/0.0	0.0/0.0	0.0/0.0	0.0/0.0	0.0
F3-Nd2	0.0/0.0	0.0/0.0	0.0/0.0	0.0/0.0	0.0/0.0	0.0/0.0	0.0
F3-Nd3	0.0/0.0	0.0/0.0	0.0/0.0	0.0/0.0	0.0/0.0	0.0/0.0	0.0
F4-Nd1	0.0/0.0	0.0/0.0	0.0/0.0	0.0/0.0	0.0/0.0	0.0/0.0	0.0
F4-Nd3	0.0/0.0	0.0/0.0	0.0/0.0	0.0/0.0	0.0/0.0	0.0/0.0	0.0
Total	0.0/0.0	-4.3/-4.3	-29.9/-29.9	-9.7/-9.7	-6.6/-6.6	12.3/12.3	

Table 4.10. Benefits [€M/yr] obtained by generators from each TEP project using the PINT approach

Firm-Node	Project						Total
	2-4 (1,2)	2-5 (1,2)	2-6 (1,2)	3-8 (1,2)	5-8 (1,2)	6-9 (1,2)	
F1-Nd1	0.0/0.0	0.0/0.0	0.0/0.0	0.0/0.0	0.0/0.0	210.2	420.5
F1-Nd2	0.0/0.0	0.0/0.0	0.0/0.0	0.0/0.0	0.0/0.0	0.0/0.0	0.0
F1-Nd3	0.0/0.0	-42.0/-42.0	0.0/0.0	-42.0/-42.0	-128.9/-128.9	2,434.4/2,434.4	4,442.7
F1-Nd6	0.0/0.0	-45.5/-45.5	-47.5/-47.5	-45.5/-45.5	-139.6/-139.6	2,685.3/2,685.3	4,814.2
F1-Nd8	0.0/0.0	0.0/0.0	0.0/0.0	80.6/80.6	46.9/46.9	0.0/0.0	255.0
F2-Nd1	0.0/0.0	0.0/0.0	0.0/0.0	0.0/0.0	0.0/0.0	6.6/6.6	13.1
F2-Nd2	0.0/0.0	0.0/0.0	0.0/0.0	0.0/0.0	0.0/0.0	0.0/0.0	0.0
F2-Nd3	0.0/0.0	-26.3/-26.3	0.0/0.0	-26.3/-26.3	-26.3/-26.3	1,521.5/1,521.5	2,885.3
F3-Nd1	0.0/0.0	0.0/0.0	0.0/0.0	0.0/0.0	0.0/0.0	0.0/0.0	0.0
F3-Nd2	0.0/0.0	0.0/0.0	0.0/0.0	0.0/0.0	0.0/0.0	0.0/0.0	0.0
F3-Nd3	0.0/0.0	0.0/0.0	0.0/0.0	0.0/0.0	0.0/0.0	760.8/760.8	1,521.5

F4-Nd1	0.0/0.0	0.0/0.0	0.0/0.0	0.0/0.0	0.0/0.0	0.0/0.0	0.0
F4-Nd3	0.0/0.0	0.0/0.0	0.0/0.0	0.0/0.0	0.0/0.0	757.3/757.3	1,514.5
Total	0.0/0.0	-113.9/-113.9	-47.5/-47.5	-33.3/-33.3	-248.0/-248.0	8,376.1/8,376.1	

Table 4.11. Benefits [€/yr] obtained by generators from each TEP project using the TOOT approach

Firm-Node	Project						Total
	2-4 (1,2)	2-5 (1,2)	2-6 (1,2)	3-8 (1,2)	5-8 (1,2)	6-9 (1,2)	
F1-Nd1	0.0/0.0	0.0/0.0	0.0/0.0	0.0/0.0	0.0/0.0	0.0/0.0	0.0
F1-Nd2	0.0/0.0	0.0/0.0	0.0/0.0	0.0/0.0	0.0/0.0	0.0/0.0	0.0
F1-Nd3	0.0/0.0	0.0/0.0	0.0/0.0	0.0/0.0	0.0/0.0	0.0/0.0	0.0
F1-Nd6	0.0/0.0	0.0/0.0	-1,041.5/-1,041.5	-1.3/-1.3	-1.3/-1.3	0.0/0.0	-2,088.1
F1-Nd8	0.0/0.0	0.0/0.0	0.0/0.0	-9.0/-9.0	7.2/7.2	0.0/0.0	-3.6
F2-Nd1	0.0/0.0	0.0/0.0	0.0/0.0	0.0/0.0	0.0/0.0	0.0/0.0	0.0
F2-Nd2	0.0/0.0	0.0/0.0	0.0/0.0	0.0/0.0	0.0/0.0	0.0/0.0	0.0
F2-Nd3	0.0/0.0	0.0/0.0	0.0/0.0	0.0/0.0	0.0/0.0	0.0/0.0	0.0
F3-Nd1	0.0/0.0	0.0/0.0	0.0/0.0	0.0/0.0	0.0/0.0	0.0/0.0	0.0
F3-Nd2	0.0/0.0	0.0/0.0	0.0/0.0	0.0/0.0	0.0/0.0	0.0/0.0	0.0
F3-Nd3	0.0/0.0	0.0/0.0	0.0/0.0	0.0/0.0	0.0/0.0	0.0/0.0	0.0
F4-Nd1	0.0/0.0	0.0/0.0	0.0/0.0	0.0/0.0	0.0/0.0	0.0/0.0	0.0
F4-Nd3	0.0/0.0	0.0/0.0	0.0/0.0	0.0/0.0	0.0/0.0	0.0/0.0	0.0
Total	0.0/0.0	0.0/0.0	-1,041.5/-1,041.5	-10.3/-10.3	5.9/5.9	0.0/0.0	

Table 4.12. Benefits [€/yr] obtained by TOs from each TEP project using the AS approach

TOs	Project						Total
	2-4 (1,2)	2-5 (1,2)	2-6 (1,2)	3-8 (1,2)	5-8 (1,2)	6-9 (1,2)	
1-2	12.1/12.1	0.0/0.0	0.5/0.5	0.0/0.0	0.0/0.0	-3.0/-3.0	19.2
1-4	-12.1/-12.1	0.0/0.0	-0.5/-0.5	0.0/0.0	0.0/0.0	3.0/3.0	-19.2
2-3	0.0/0.0	13.3/13.3	2.6/2.6	-3.6/-3.6	30.5/30.5	-21.3/-21.3	42.9
2-4	0.0/0.0	0.0/0.0	0.0/0.0	0.0/0.0	0.0/0.0	0.0/0.0	0.0
2-5	0.0/0.0	-0.4/-0.4	0.1/0.1	-2.2/-2.2	-4.7/-4.7	1.2/1.2	-11.9
2-6	0.0/0.0	0.0/0.0	-3.7/-3.7	0.1/0.1	0.4/0.4	14.4/14.4	22.4

3-5	0.0/0.0	-13.0/-13.0	-2.3/-2.3	1.5/1.5	-37.0/-37.0	21.9/21.9	-57.9
4-6	0.0/0.0	0.2/0.2	1.3/1.3	0.8/0.8	1.9/1.9	1.9/1.9	12.0
5-6	0.0/0.0	-0.3/-0.3	4.7/4.7	-1.2/-1.2	-2.8/-2.8	-23.7/-23.7	-46.6
6-7	0.0/0.0	0.2/0.2	2.2/2.2	0.8/0.8	1.9/1.9	-234.3/-234.3	-458.3
6-9	0.0/0.0	0.2/0.2	2.8/2.8	1.1/1.1	2.5/2.5	-340.0/-340.0	-666.5
7-9	0.0/0.0	0.0/0.0	-0.5/-0.5	-0.1/-0.1	-0.3/-0.3	21.8/21.8	41.7
2-4 (1)	29.6/0.0	0.0/0.0	0.0/0.0	0.0/0.0	0.0/0.0	0.0/0.0	29.6
2-4 (2)	0.0/29.6	0.0/0.0	0.0/0.0	0.0/0.0	0.0/0.0	0.0/0.0	29.6
2-5 (1)	0.0/0.0	35.3/0.0	0.0/0.0	-0.3/-0.3	-0.4/-0.4	0.0/0.0	34.0
2-5 (2)	0.0/0.0	0.0/35.3	0.0/0.0	-0.3/-0.3	-0.4/-0.4	0.0/0.0	34.0
2-6 (1)	0.0/0.0	0.0/0.0	6.8/-2.5	0.0/0.0	0.0/0.0	3.8/3.8	11.8
2-6 (2)	0.0/0.0	0.0/0.0	-2.5/6.8	0.0/0.0	0.0/0.0	3.8/3.8	11.8
3-8 (1)	0.0/0.0	-0.2/-0.2	0.0/0.0	8.4/-1.2	-5.2/-5.2	0.2/0.2	-3.2
3-8 (2)	0.0/0.0	-0.2/-0.2	0.0/0.0	-1.2/8.4	-5.2/-5.2	0.2/0.2	-3.2
5-8 (1)	0.0/0.0	-0.3/-0.3	0.0/0.0	-5.2/-5.2	30.3/-13.6	0.5/0.5	6.8
5-8 (2)	0.0/0.0	-0.3/-0.3	0.0/0.0	-5.2/-5.2	-13.6/30.3	0.5/0.5	6.8
6-9 (1)	0.0/0.0	0.0/0.0	3.8/3.8	0.6/0.6	1.1/1.1	977.4/-988.4	0.0
6-9 (2)	0.0/0.0	0.0/0.0	3.8/3.8	0.6/0.6	1.1/1.1	-988.4/977.4	0.0
Total	29.6/29.6	34.7/34.7	19.1/19.1	-5.3/-5.3	0.1/0.1	-560.1/-560.1	

4.2.3 Analysis and discussion

The analysis of the benefits deemed to be produced by expansion projects and the benefits each of these projects provide to the individual users of the network, according to each method considered, allows an assessment of whether this benefit assessment method has each of the desirable features identified and discussed in Chapter 2.

Firstly, it has to be noticed that, within the three methods applied, only AS provides individual project's benefits that add up to the total benefits actually produced by the whole plan (€4,225M/year). This has already been highlighted in Chapter 2. Moreover, this also implies that benefits deemed to be obtained by network users from expansion projects only add up to the actual benefits obtained by these same users from the whole expansion plan when the AS method is applied to compute the former. This can be checked by comparing Table 4.6 to Table 4.12 with Table 4.3 and Table 4.4. For instance, Firm 1's generation unit in node 6 obtains a very large negative overall benefit from the

whole set of expansion projects according to TOOT ($-\text{€}2,088.1\text{M}/\text{yr}$), and a huge positive one according to PINT ($\text{€}4,814.2\text{M}/\text{yr}$), while the real overall benefits obtained by this unit from the expansion plan are negative and small in magnitude ($-\text{€}111.9\text{M}/\text{yr}$).

Going into greater detail, it can be seen that the results provided by PINT and TOOT are counterintuitive. For example, according to PINT, projects 6-9 (circuits 1 and 2) would not benefit consumers in node 9. This result does not make sense because the objective of these two projects is to strengthen the connection between node 9 and the rest of the system. Thus, both projects would benefit consumers located in this node by removing the ENS in this location. It is also interesting to note that, according to TOOT, projects 2-5 (circuits 1 and 2) do not benefit any user (consumers, generators or TOs). This is also counterintuitive, since these projects make low-cost generation located in node 2 available to consumers in other nodes. Therefore, these projects would actually positively benefit these consumers, who would pay a lower price for the energy consumed⁶⁵. On the other hand, these same projects would negatively affect generators located in other nodes, who would be partially replaced in the dispatch by the low-cost unit in node 2 and would sell their energy at a lower price. This is in line with the results produced by the method proposed. According to these, projects 2-5 (circuits 1, and 2) would benefit consumers located in nodes other than 2 and would reduce the market benefits of almost all generators except those in node 2, since they would help Firm 2 to increase the generation of its unit in node 2 (which is the cheapest one in the system).

As previously discussed in Chapter 2, PINT and TOOT assume a specific order of deployment of projects. This implies that these methods do not appropriately capture the interactions taking place among projects regarding the effect that the deployment of some has on the benefits produced by others. The incremental benefits produced by projects largely depend on which others have been installed before them. Then, the benefits produced by projects according to PINT and TOOT are not representative of all the incremental benefits that these projects may produce across the many possible orders in which the set of projects in the expansion plan may be deployed. Thus, for example, projects 2-5 (circuits 1 and 2) are deemed not to produce any benefit according to TOOT, because these two are alternative projects playing the same role. In this case, TOOT underestimates the benefits actually produced by each project. Contrary to this, applying

⁶⁵ The fact that these results are counterintuitive may also complicate the deployment of the projects, since the level of acceptance of these results, and therefore the corresponding allocation of the costs of the reinforcements concerned, by the stakeholders involved could be low. It would be difficult to explain the function carried out by a project, or objective of this expansion project, while the results provided by these two methods (PINT and TOOT) on the benefits the project creates point out to the fact that the project is carrying out another function.

PINT results in an overestimation of the benefits produced by these two projects, since the benefits that could be produced by either of the two projects alone are fully assigned to each of them. Moreover, the PINT method is not able to take into account the complementarities existing among projects. Two or more projects are complementary when some benefits are only realized when all these projects are deployed together. According to PINT, consumers located in nodes 7 and 9 would not benefit from projects 2-6 (circuits 1 and 2), 3-8 (circuits 1 and 2) or 5-8 (circuits 1 and 2). PINT does not take into account the fact that, as a result of the deployment of projects 6-9 (circuits 1 and 2), more load would have to be supplied in the system, the increase corresponding to part of the load located in nodes 7 and 9, which was previously not being served. Then, not deploying projects 2-6 (circuits 1 and 2), 3-8 (circuits 1 and 2) and 5-8 (circuits 1 and 2) would result in a further increase in the system prices, including those applied at nodes 7 and 9. Aumann-Shapley, in contrast, is able to capture interactions existing among projects, like those just discussed. Thus, according to the AS method proposed, consumers located in nodes 7 and 9 would benefit from projects 2-6 (circuits 1 and 2), 3-8 (circuits 1 and 2) and 5-8 (circuits 1 and 2). As mentioned, projects 6-9 (1,2) would help to avoid the ENS incurred by consumers in nodes 7 and 9, which would result in more load being supplied, and an increase in the prices in the system if the former expansion projects were not deployed.

Results provided by the AS method are coherent and can help planners and authorities to explain the function of each expansion project. For instance, AS results show that the expansion projects 6-9 (circuits 1 and 2), are the only ones responsible of an increase in the security of supply in the system (i.e. the reduction in the ENS). These projects are allowing more energy to be supplied to consumers located in nodes 7 and 9. Furthermore, projects 2-4 (circuits 1 and 2), are the main ones responsible of the increase taking place in the amount of RES energy integrated into the system, accounting each one of them for about 22% of the increase in RES electricity production. Other projects significantly contributing to the integration of RES energy are projects 2-5 and 5-8.

The cost of the new transmission projects may be allocated to the users of the network proportionally to the benefits that the latter are expected to obtain from the former (application of the “beneficiary pays” principle). In this case, network charges paid by users would largely depend on the benefit allocation method applied. If TOOT were applied, no consumer would have to pay for projects 2-5 (circuits 1 and 2), while some consumers would actually benefit from these projects, as we have just argued. Moreover, if PINT were applied, Firm 3’s unit in node 1 and Firm 4’s unit in node 3 would have to pay part of the cost of projects 6-9 (circuits 1 and 2). This does not seem to make sense, since these units would not obtain any positive benefit from the expansion plan. In fact,

once the plan is implemented, these units would not be able to produce any energy (see Table 4.3). Hence, they would be negatively affected by the plan.

It is also important to remark that, contrary to other methods using AS for the allocation of the fixed costs of networks, the proposed method endogenously determines the fraction of the cost of each line to be paid by generators as a whole, that to be paid by consumers as a whole, and, therefore, which fraction (the remaining one) shall be paid by the owners of other lines in the network. Besides, the proposed method is able to determine which specific type of benefits (e.g. reducing ENS or generating with cheaper units) are provided by each line⁶⁶.

4.3 CASE STUDY: 118-BUS POWER SYSTEM

The previous case study is small. Thus, the results produced by the several benefit assessment methods considered can be analyzed in detail. The case study considered in this section, on the other hand, allows to show the applicability of the method proposed to larger power systems (and expansion plans), even to those of a real-life size. The analyses conducted for this case study comprise the following:

- 1) Estimating the benefits of expansion projects and computing a ranking of expansion projects according to the size of these benefits.
- 2) Selecting the priority projects using the benefit-based ranking previously computed. This selection is accomplished considering several methods for this in order to compare their performance.
- 3) Categorizing the expansion projects selected based on the type of benefits they provide, i.e. identifying the main function of the expansion projects.
- 4) Allocating the cost of the expansion projects according to the “beneficiary pays” principle. In order to do this, the benefits obtained by the individual network users from the individual expansion projects must be computed first.

Fig. 4.2 shows the power system in this case study. The set of reinforcements considered within each expansion project are given as inputs. In this case, as in the former, each new line to be installed is considered a stand-alone project, and all of them are reinforcements of already existing corridors. We consider three operation situations as representative of all those that may occur in the relevant time frame (target year of network expansion planning horizon where the operation of the system is analyzed). The duration of the blocks of hours represented by these operation snapshots is 5,700, 1,500 and 1,560 hours,

⁶⁶ Please see sections 3.1 and 3.3.2 in Chapter 3 for more details.

respectively. The TEP comprises 30 projects. The power system considered is based on the IEEE-118 bus system⁶⁷. This power system has been modified in order to include some RES generation units (with very low variable production costs and zero CO₂ emissions). These RES units are located in nodes 36, 69 and 77. We have considered a WACC of 7.5% per year and a 40-year amortization period for all the expansion projects. We assume a linear relationship between the capacity and admittance of new transmission assets affected by projects ($y_{l(ij)} = \alpha \overline{F_{l(ij)}}$) because all of the projects considered are full AC lines. The AS method is applied in this case study taking 1,117 steps in the implementation process⁶⁸. The number of steps taken is selected in order to compute the benefits and beneficiaries of expansion projects with enough accuracy.

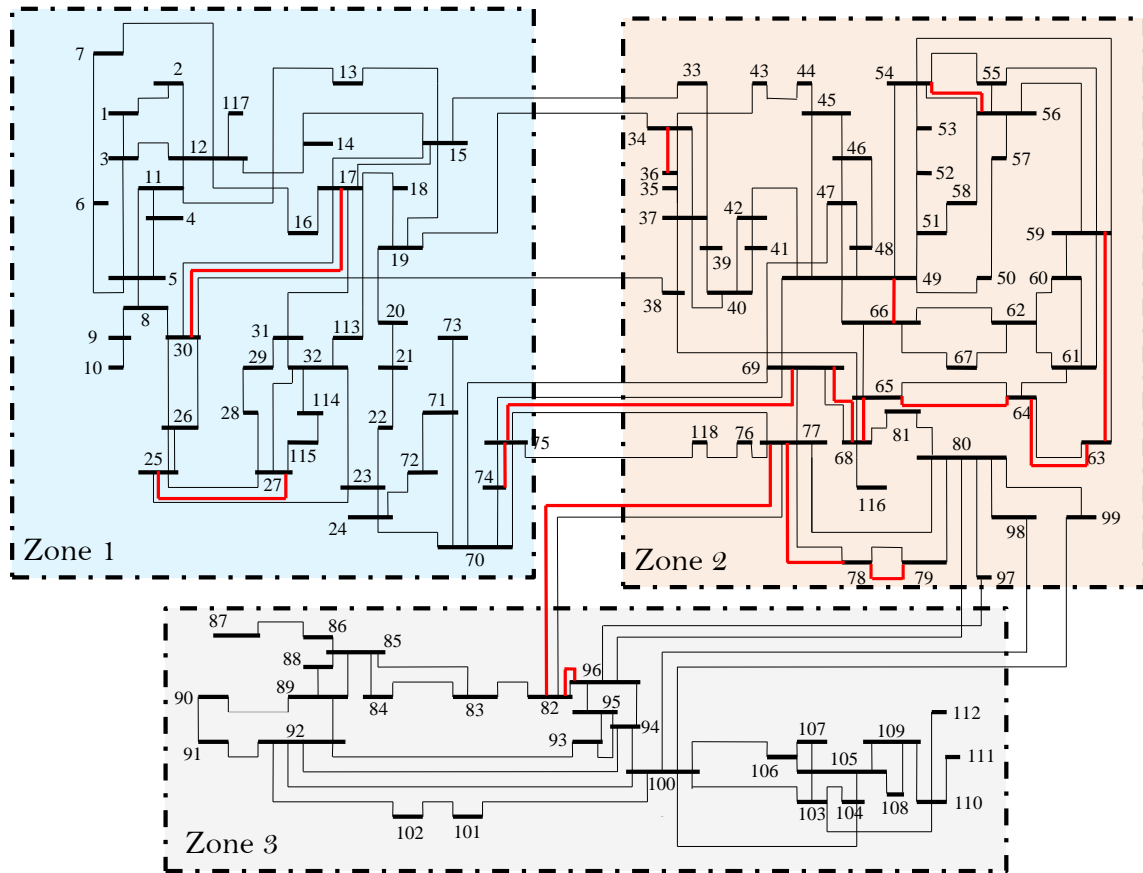

⁶⁷ The original power system includes 118 nodes, 62 generation units and 256 transmission lines. Generators, demand and transmission network data for the considered system and for the expansion projects are provided in Appendix C.

⁶⁸ The execution time of the proposed method in this case study was about 3,000 seconds. Some of the techniques explained in Appendix B have been implemented in the TEPES model to execute this case study.

Fig. 4.2. 118-Bus power system schematic representation. The original network in the system is depicted using black lines, while TEP projects are depicted using red lines.

The method based on the computation of the Shapley value of projects is not considered in this case because, as previously discussed in Chapter 2 and above in this same chapter, its application to cases of a real-life size is almost impossible. In this case, the total number of permutations of expansion projects corresponding to the number of deployment orders of projects that the Shapley method considers amounts to $30!$ (more than $2 \cdot 10^{32}$).

The deployment of the TEP results in an increase of the SW of €1,383M/year. The net benefits of the plan, calculated by deducting the overall investment cost of projects from the overall system benefits they produce, amount to €959M/year.

4.3.1 Estimating the benefits of individual expansion projects and computing their ranking

The increase in the efficiency of the economic dispatch (ED), and the benefit to cost ratio (B/C) for each project, according to the several methods considered, are shown in Table 4.13. The ranking of projects, determined according to their benefit to cost ratio computed based on the results produced by each method, is also shown in Table 4.13 (third column of those corresponding to each method).

Similarly to what happens for the previous case study, and in line with the results computed for the example discussed in chapters 2 and 3, the benefits assigned to each project may largely depend on the method applied. Only the benefits attributed to individual projects in the method proposed add up to the total benefits produced by the whole TEP. In this case, again, TOOT underestimates the benefits of individual projects (€1,294M/yr), while PINT overestimates them (€1,406M/yr). As a consequence, the differences existing among the three rankings computed making use of the results produced by the three methods are also large. For instance, projects reinforcing the connection between nodes 34 and 36 are ranked lowest in TOOT, while using the proposed method and PINT they are ranked in the top ten. Please, note also that the PINT approach assigns a negative value, or benefit, to several expansion projects because these need of other projects to produce some system benefits (the former and the latter are complementary projects) and PINT is not able to assign to any project those benefits only resulting from the joint deployment of several.

Table 4.13. Overall dispatch benefits [€M/year] produced by expansion projects and their ranking according to the benefit to cost ratio computed for each project according to each method

Project	AS			TOOT			PINT		
	ED	B/C	#	ED	B/C	#	ED	B/C	#
25-27	100	1.7	22	87	1.5	23	116	2.0	18
30-17	47	3.3	10	32	2.3	13	40	2.8	17
34-36 (1)	53	7.4	6	14	1.9	22	96	13.4	3
34-36 (2)	53	5.4	8	14	1.4	24	96	9.8	5
49-66	31	0.9	28	34	1.0	25	27	0.8	24
54-56 (1)	10	2.8	14	0	-0.1	29	21	6.0	8
54-56 (2)	10	2.8	15	0	-0.1	29	21	6.0	8
63-59 (1)	17	1.2	25	13	0.9	26	17	1.2	21
63-59 (2)	17	1.2	26	13	0.9	26	17	1.2	21
63-59 (3)	17	1.2	27	13	0.9	26	17	1.2	21
63-64 (1)	11	1.6	24	15	2.1	20	9	1.3	19
63-64 (2)	11	1.6	23	15	2.1	20	9	1.3	19
64-65 (1)	29	2.6	18	25	2.3	10	34	3.1	14
64-65 (2)	29	2.6	17	25	2.3	10	34	3.1	14
64-65 (3)	29	2.6	16	25	2.3	10	34	3.1	14
65-68 (1)	11	1.9	19	12	2.1	17	4	0.6	25
65-68 (2)	11	1.9	21	12	2.1	17	4	0.6	25
65-68 (3)	11	1.9	20	12	2.1	17	4	0.6	25
68-69 (1)	111	15.6	1	120	16.7	1	90	12.6	4
68-69 (2)	111	8.3	4	120	8.9	3	90	6.7	6
68-69 (3)	111	8.3	5	120	8.9	3	90	6.7	6
69-75	28	3.9	9	56	7.8	7	-38	-5.4	30
74-75	106	7.2	7	138	9.3	2	79	5.3	10
77-78 (1)	64	14.2	2	36	8.0	5	80	17.6	1
77-78 (2)	64	14.2	3	36	8.0	5	80	17.6	1
77-82 (1)	97	3.1	12	69	2.2	14	120	3.9	11
77-82 (2)	97	3.1	13	69	2.2	14	120	3.9	11
77-82 (3)	97	3.1	11	69	2.2	14	120	3.9	11
78-79	0	0	30	53	6.0	8	-13	-1.4	29
82-96	1	0.0	29	46	2.4	9	-9	-0.4	28
Total	1,383	-	-	1,294	-	-	1,406	-	-

4.3.2 Selecting priority projects

As aforementioned, computing the benefits produced by the projects in the TEP can be useful to select priority projects. These could be the first to be deployed if the funds available were scarce. Following the example set by EU authorities, who have developed the Projects of Common Interest list, these projects should, at least, be subject to preferential regulatory treatment and have priority access to financing.

The three considered methods to select the priority projects are applied here. Several possible overall amounts of funds available for network expansion are considered to check the sensitivity of results with respect to this parameter. Only the projects designated as priority ones in each case are implemented. Furthermore, the best transmission expansion plan is also computed for each limitation of funds available. Fig. 4.3 shows the evolution of the net benefits obtained by the system from the priority projects selected when the B/C ratios in Table 4.13 for each method are used to select these priority projects. This figure also displays the net benefits obtained when implementing the best expansion plan that complies with the maximum amount of funds to be spent on it⁶⁹. These values can be seen as a measure of the efficiency of each method to select the priority projects.

⁶⁹ Please note that this implies computing the transmission expansion plan for each budget limit. However, transmission expansion planning is a very complex problem (Latorre et al. 2003; Lumbreras & Ramos 2016). Thus, it could be difficult, or even impossible, to compute the optimal transmission expansion plan several times.

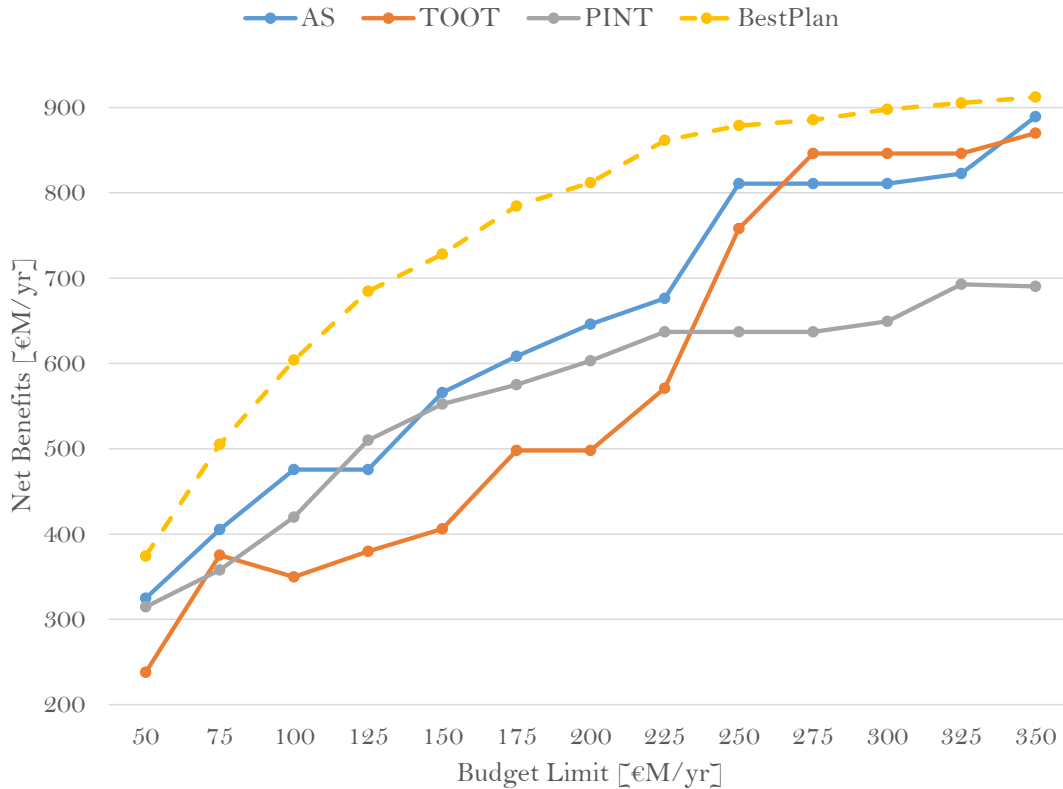

Fig. 4.3. Evolution with the network expansion budget of the net system benefits [€M/yr] resulting from the deployment of priority projects. The evolution of the net benefits obtained for the re-computed expansion plans complying with the different budget limits are represented with dashed lines.

The net benefits obtained when deploying those priority projects selected according to the method proposed here are usually larger than those resulting from the use of TOOT and PINT to select these projects. In the worst case, benefits obtained selecting the priority projects according to the proposed AS method are close to the largest ones. On the other hand, the performance of the TOOT and PINT methods is quite erratic. For a small budget, projects selected with PINT result in larger net benefits than those selected with TOOT. However, as the budget limit increases, TOOT performs better in comparative terms.

Let us now assume that there is a budget limit of €200M/year to invest in the expansion of the network. The ranking obtained with the AS method proposed is used to select the projects that will be given priority. The projects selected according to this method are listed in Table 4.14.

Table 4.14. Priority projects selected using the AS method proposed

Priority projects
Project 30-17
Projects 34-36 (circuits 1 and 2)
Projects 54-56 (circuits 1 and 2)
Projects 68-69 (circuits 1, 2 and 3)
Project 69-75
Project 74-75
Project 77-78 (circuits 1 and 2)
Projects 77-82 (circuits 1, 2 and 3)

4.3.3 Understanding the objective/purpose of expansion projects

Although the final number of expansion projects being selected as priority ones is not so high –15 projects–, it is difficult to know the main function, or objective achieved through the deployment, of each project. Therefore, the aim now is to determine the benefits of each kind created by each expansion project. The type of benefits considered are: security of supply, reduction of CO₂ emissions, integration of RES generation or economic benefits⁷⁰. Please note that, although these benefits may be represented, or considered, as components of the SW (and thus, be measured in monetary terms), they are considered here as benefits by themselves. This is in accordance with the fact that these benefits are also established as objectives by the authorities.

The benefits produced by the deployment of the priority projects (listed in Table 4.14), computed as the change in the corresponding index with respect to the situation where none of the expansion projects is deployed, are shown in Table 4.15. In this case, there is not any increase in security of supply caused by the deployment of projects because there is no load curtailment in the power system before the expansion of the network takes place⁷¹. The reduction in the operation costs of the system, which results in an increase in SW, is associated both with the increase in the energy produced by wind generation units,

⁷⁰ Economic benefits (or increase in the SW) implicitly include the reduction in the operational costs of the system by producing electricity with RES units (cheaper) instead of thermal units (more expensive).

⁷¹ Contrary to the previous case study, the results presented in this case are not dependent on the cost assigned to the ENS.

whose variable production costs are lowest, and with the reduction of the CO₂ emissions produced by the thermal units.

Table 4.15. Change, with respect to the situation where none of the expansion projects is deployed, taking place in the different types of benefits considered for the 118-bus power system resulting from the deployment of the priority expansion projects (computed using the AS method).

Type of benefit	Variation	
SW increase	€843M/yr	11%
SoS increase	0TWh/yr	0%
CO ₂ reduction	15.4MtCO ₂ /yr	4%
RES integration	36.8TWh/yr	39%

The increase in RES generation and the reduction in CO₂ emissions produced by each expansion project are displayed in Fig. 4.4. The increases in RES generation and the reductions in CO₂ emissions displayed in this figure for individual projects add up to the total variation of these benefits shown in Table 4.15⁷². Interestingly, some projects are not helping to integrate more RES generation into the system, nor to reduce the CO₂ emissions, but rather the contrary:

- RES integration. Every expansion project but projects 30-17, and 54-56 (circuits 1 and 2) is helping to integrate more RES generation (that produced by wind generators located in nodes 36, 69 and 77). One could expect that those expansion projects directly connecting those nodes where RES generation units are located to the rest of the system are those contributing to a largest extent to the integration of this generation. However, project 74-75, which is not directly connected to any node where RES generation units are, is contributing to the largest extent to the integration of RES generation. Project 74-75 is providing a path to export the energy produced by the wind generator located in node 69 to the consumers in zone 1. The rest of the projects helping to increase the amount of electricity produced by RES generation in the power system are directly connected to the nodes where the wind generation units are located, e.g. projects 68-69 (circuits 1, 2 and 3).

⁷² Remember that this is one of the properties of the method proposed here, as explained in detail in Chapter 3.

- CO₂ emission reduction. Contrary to what happens for the integration of RES generation, almost half of the expansion projects turn out to be detrimental to the reduction of CO₂ emissions, i.e. they actually increase these emissions⁷³. This is the case of projects 30-17, 54-56 (circuits 1 and 2), 74-75, 77-78 (circuits 1 and 2). It is very interesting to notice that the increase in the integration of RES generation in the system by expansion projects is not necessarily positively correlated to the reduction of CO₂ emissions these same project produce (although it is the most common situation). In order to be able to produce power making use of some units (for example, the RES units), it is sometimes necessary to increase the production of (or start producing with) some other units (the thermal ones) in order for the resulting flows in lines or corridors to be compatible with their capacity. This is the situation of projects 74-75 and 77-78 (circuits 1 and 2). Project 74-75, which is allowing the largest increase in RES generation to take place, is also leading, however, to the largest increase in CO₂ emissions among all the expansion projects. This is so because, although this project is achieving an increase in the energy produced by the wind unit located in node 69, it is also contributing to increase the production of some thermal units (units 20 and 36), which is required for the production of the wind unit in node 69 to increase. Similarly, projects 77-78 (circuits 1 and 2) are also achieving an increase in the amount of electricity produced by RES generation (wind units located in nodes 69 and 77) and an increase in the amount of emissions of CO₂ in the power system (although much lower than that caused by project 74-75). The latter is due to the increase in the production of unit 20 these projects are achieving. On the other hand, projects 34-36 (circuits 1 and 2), 68-69 (circuits 1, 2 and 3), 69-75 and 77-82 (circuits 1, 2 and 3) are contributing both to the increase in the amount of energy produced by RES generation in the system and the reduction of CO₂ emissions. These projects are not only integrating additional RES energy, but also helping the system to reduce the amount of energy produced with thermal units (or to replace units with a higher CO₂ intensity with others with a lower emission rate). This is the case, for example, of projects 77-82 (circuits 1, 2 and 3), which are facilitating the production with the wind unit in node 77 and, at the same time, achieving a reduction in the production of unit 37 (one of the units with the highest CO₂ emission rate). In the same way, projects 68-69 (circuits 1, 2 and 3) are helping the system to integrate the energy produced by the wind generator located in node 69, while reducing the production of several thermal units located close to this unit (units 27 and 28).

⁷³ Some of these projects increase the emissions in a very limited amount.

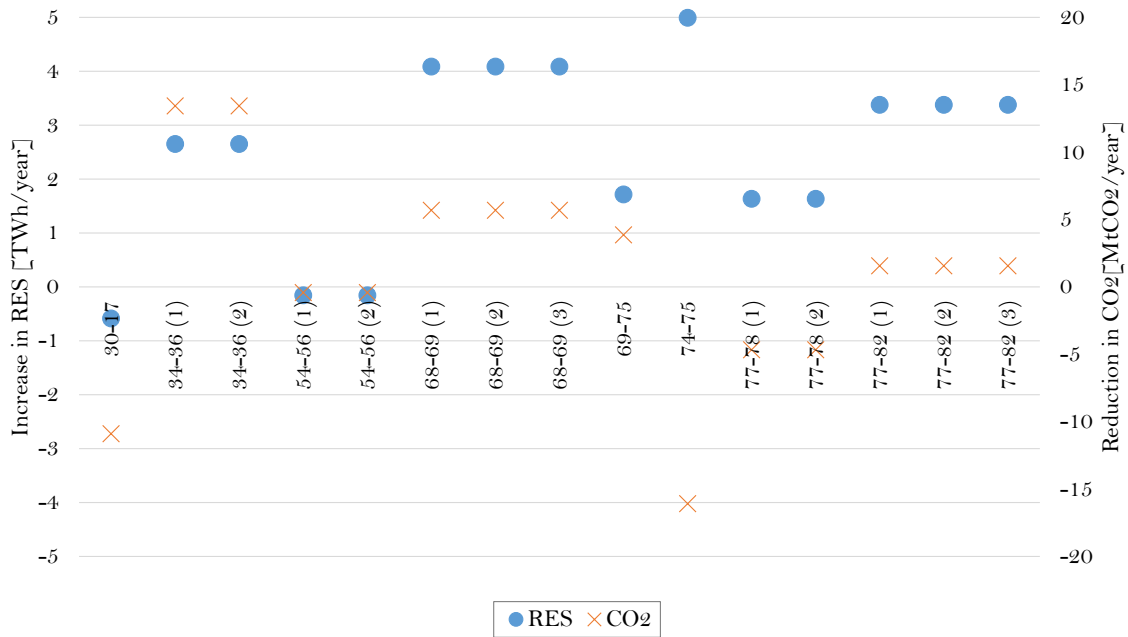

Fig. 4.4. Increase achieved by expansion projects, with respect to the situation where none of the expansion projects is deployed, in the amount of RES electricity produced (blue points), which is represented considering the left axis, and reduction of CO₂ emissions achieved by these projects (orange crosses), which is represented considering the right axis.

4.3.4 Who is benefiting from expansion projects?

As mentioned above, the deployment of the priority projects of the expansion plan produces an increase in the SW of the system. This increase in SW can be decomposed into the increases in the market, or dispatch, benefits obtained by the individual users of the network, or by the groups of them that may be defined (generators, consumers and network owners). It is important to remark that causing a positive increase in SW does not mean that all the network users achieve a positive increase in their benefits. In fact, normally, some users increase their market benefits as a result of the deployment of a project, or the whole plan, while other users see how their market benefits decrease, i.e. they are harmed by the deployment of this project or plan. Table 4.16 shows the overall benefits obtained by each of the several types of network users –generators, consumers and TOs– from the joint deployment of all the priority projects previously selected using the AS method. The main beneficiaries from these projects are the consumers, who would face lower energy prices as a result of the deployment of these projects. On the other hand, this reduction in prices would negatively affect both the generators and the TOs almost to the same extent.

Table 4.16. Distribution of the overall dispatch benefits [€M/year] produced by the priority expansion projects as a whole among generators, consumers and transmission owners

Type of user	Benefit (ED)
Generators	-€2,008M/year
Consumers	€5,298M/year
Transmission Owners	-€2,447M/year
Total	€843M/year

Table 4.16 provides a distribution of the overall benefits obtained by each groups of network users from all the priority projects as a whole, but it is not providing the contribution of each expansion project to these benefits. The benefit provided by each expansion project to each group of users is displayed in Fig. 4.5. This figure shows that the positive benefits obtained by consumers are mainly produced by three expansion projects: project 74-75 and projects 77-78 (circuits 1 and 2). The reader should also notice that, although generators are obtaining negative benefits from the deployment of the priority expansion projects as a whole, some of these projects are actually bringing positive benefits to them, e.g. project 30-17.

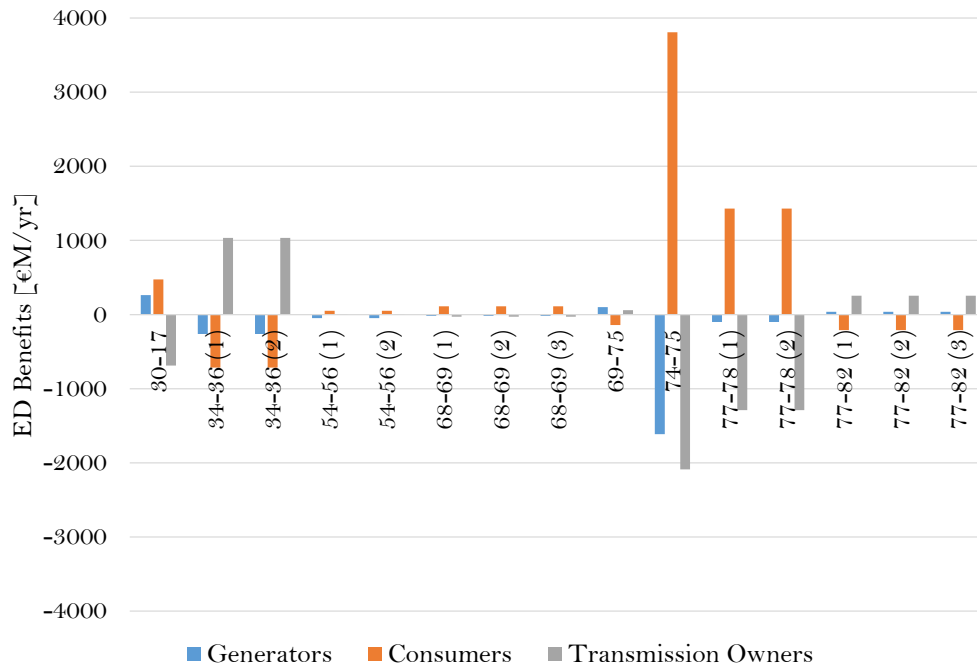

Fig. 4.5. Economic dispatch benefits provided by each expansion project differentiated by the type of user: generators, consumers and transmission owners.

Focusing now on the benefits obtained by the individual network users from specific projects, Table 4.17 shows those network users obtaining the largest (positive and negative) benefits from each expansion project (three network users are selected for each project). The case of the expansion project 74-75, which is the one producing the largest benefits for the whole system, shall be discussed first. The consumers located in nodes 6, 13 and 18 are the largest beneficiaries of this project. These consumers together obtain about 50% of the total positive benefits that consumers in the system obtain from this project. Among generation units, the unit "G7" is the most affected by this expansion project, accounting for more than 50% of the total negative benefits obtained by generators from this project. It is also interesting to see that, despite producing positive benefits for consumers as a whole, projects 77-78 (circuits 1 and 2) are also having a significant negative effect on the market benefits of some of the consumers, namely those located in node 34. Project 30-17 is increasing the benefits of generators as a whole but, similarly to what has just been mentioned for projects 77-78 (circuits 1 and 2), it is also producing negative incremental benefits for some generators (unit "G5" is especially affected). It is also noteworthy to mention that, although consumers are the main beneficiaries of the expansion plan, some projects, such as projects 34-36 (circuits 1 and 2) and 77-82 (circuits 1, 2 and 3), are negatively affecting the consumers located in zone 2 (nodes 33, 39 and 79 are all located in this zone). These projects are benefiting the consumers in other zones by causing a decrease in the energy prices they pay. However, power exchanges enabled by these projects between zone 2 and other zones are causing an increase in the price in (some nodes of) zone 2.

The benefits that the network users in each zone (as indicated in Fig. 4.2) obtain from each expansion project are displayed in Fig. 4.6. Then, the benefits of each zone from each project are the sum of the benefits (positive and negative) obtained by the individual network users located in each zone from that project. Most of the projects are internal to a zone (see Fig. 4.2). However, as it can be seen in Fig. 4.6, almost every project (not only the inter-zonal, or cross-zonal ones) is affecting the market benefits of the network users located in several zones. This is especially relevant when determining the cost allocation of these projects.

Table 4.17. Network users obtaining the largest (positive and negative) benefits [€/yr] from each expansion project. Generators are identified with a “G”, consumers are identified with a “C”, and the number of the node where they are located

Project	User and benefits					
	Positive			Negative		
30-17	G7	C19	11-13	C18	G5	18-19
	1,227	418	352	-1,170	-649	-634
34-36 (1,2)	33-37	37-39	C34	C33	C39	C79
	614	540	429	-367	-343	-271
54-56 (1,2)	37-39	C34	37-40	C39	C41	38-65
	109	51	47	-71	-46	-41
68-69 (1,2,3)	68-69 (1,2,3)	C39	C41	37-39	68-69 (1)	68-69 (2)
	102	33	23	-38	-21	-21
69-75	75-118	G7	C75	69-75 (1)	69-75 (2)	C18
	98	56	45	-57	-57	-54
74-75	C18	C6	C13	G7	G5	11-13
	825	673	580	-865	-386	-366
77-78 (1,2)	C79	C39	C33	37-39	33-37	C34
	376	335	244	-485	-418	-364
77-82 (1,2,3)	77-82 (1,2,3)	33-37	78-79 (1)	C79	C33	C39
	192	83	73	-99	-53	-46

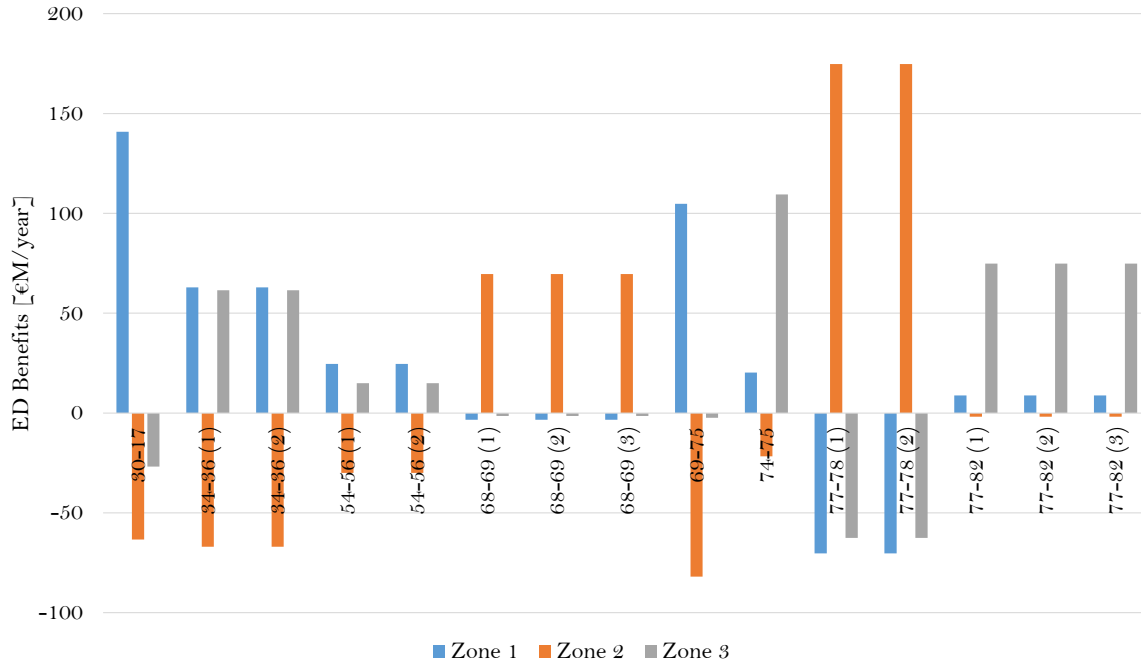

Fig. 4.6. Economic dispatch benefits obtained by each zone from each expansion project, as computed using AS. From each expansion project, the benefits of a zone are the sum of the benefits (positive and negative) obtained by the individual network users within this zone from that project.

4.3.5 Cost allocation: “beneficiary pays” principle

The responsibility of each user of the network in each new project should be the basis for the allocation of the cost of this project to the network users, as the cost causality principle states. It can be assumed that the responsibility of each network user in the undertaking of a certain project is directly proportional to the benefits that this user is expected to obtain from this project. After all, the expansion projects are undertaken because they are expected to produce some benefits for network users that considered all together exceed the cost of these projects⁷⁴. Thus, the “cause” of undertaking a project is the global benefits that this shall render all the network users of the system. Hence, applying cost causality to allocate the cost of network expansion projects can be deemed equivalent to applying the “beneficiary pays” principle. Please note that, strictly speaking, applying the “beneficiary pays” principle would involve compensating those users obtaining a negative benefit as a result of the deployment of an expansion project, i.e.

⁷⁴ This is the “golden rule” of transmission investment. Regulatory authorities should only approve new investments if this rule is satisfied.

paying these users a compensation for the losses they are expected to incur⁷⁵. However, in modern power systems like the majority of those in the most advanced regions in the world, the activities of electricity production, consumption and merchant network investment are deregulated ones subject to competitive market forces. Investors in regulated network expansion projects are guaranteed the recovery of their investment by regulation and changes in the market value, or revenues, of the facilities they own would not affect their income, which, as just mentioned, is regulated. Given this situation, there is no obligation to protect network users from the losses they may incur due to the changes taking place in the conditions of the system due to the development of the network. In any case, this is a complicated and controversial issue that should be subject of research, but is not the focus of this thesis.

Any cost allocation method applied should be fair, efficient and provide incentives to ensure that the required investments are built. On the one hand, the efficiency of a cost allocation method is related to its ability to ensure that the best investment decisions (including generation, consumption and those related to the network) are made. In principle, applying the “beneficiary pays” principle provides the best incentives to ensure the deployment of the required investments (both in generation and transmission)⁷⁶, since the agents in the network would pay for an investment in the network in proportion to the increase in their welfare they would experience with this investment in place. Then, no agent would oppose the construction of efficient network investments, whose benefits (overall increase in welfare they produce) are, by definition, larger than their cost. In this case, the efficiency of the incentives provided by the method for the installation of generators and consumers is not analyzed. In any case, one may argue that making network charges paid by network users proportional to the benefits that they obtain from the grid, which are the drivers of the installation of new transmission lines, should make these agents internalize the network costs they cause in their investment decisions. This, in turn, should lead to a tighter, more efficient, coordination of the development of generation, load and the transmission network. Besides, and for the proposed allocation method, the incentives set for the required transmission investments to be deployed are analyzed for different options regarding the treatment given to the negative benefits produced by the expansion projects.

⁷⁵ By compensating the users obtaining a negative benefit, it can be ensured that all the network users are better off once the new project is built. Then, none of the network users should oppose the undertaking of a project that is beneficial for the system, i.e. one whose benefits (positive benefits net of negative ones) are larger than its costs.

⁷⁶ Of course, this is true if the benefits and beneficiaries are computed accurately which, as said, is not an easy task.

The fairness of a cost allocation method is a concept difficult to assess which may be considered ambiguous, or subjective, by many. However, any method may be considered unfair if it discriminates among types of agents without any specific, sound, reason for this (for instance, treating differently consumers and generators, as seen later). The proposed method is not creating any kind of discrimination among groups of network users in the determination of the fraction of the cost of the grid they should pay.

The results obtained in the previous sub-section can be used for the allocation of the costs of the new expansion projects under different versions of the “beneficiary pays” principle. The following sections analyze the application of the “beneficiary pays” principle to guide the allocation of the cost of expansion projects. The consideration made of the negative benefits obtained by network users from the expansion projects depends on the circumstances existing in each of the analyses considered next.

4.3.5.1 Cost allocation at individual network user level, within a perfectly integrated system

Currently, cost allocation methods resulting in transmission charges do not provide – usually – efficient locational signals to consumers and generators. Although both consumers and generators may obtain positive benefits from the expansion of the network (see Fig. 4.5 and Table 4.17), usually consumers are the only ones that have to pay the cost of the new expansion projects (or pay the greatest share of these costs)⁷⁷.

Within a country in Europe, or perfectly integrated system, like a Regional Transmission Organization (RTO) in the USA, not compensating network users negatively affected by the undertaking of a new project generally makes sense. Users harmed by a project that is efficient for the system are not generally able to block the undertaking of this project. If these users were able to block the aforementioned project, considering the negative benefits obtained by these users in the allocation of the cost of the project, i.e. considering the payment of compensations to these users, would make sense. However, in this context, it is assumed here that paying compensations to users negatively affected by projects is not necessary.

⁷⁷ For example, in almost every country in the EU (Austria, Great Britain, Ireland, Northern Ireland, Norway, Romania and Sweden are the exception) generators do not have to pay network charges, or pay a very limited amount of them (Diyun Huang et al. 2016).

Then, only the positive benefits are taken into account here to allocate the cost of each new project⁷⁸ (i.e. no compensation is being paid to network users obtaining negative benefits). Fig. 4.7 displays the share of the costs of each selected project allocated to generators, consumers and TOs. Although this figure shows the allocation of costs aggregating network users by its type, each network user has been considered independently when allocating the cost of network reinforcements to them.

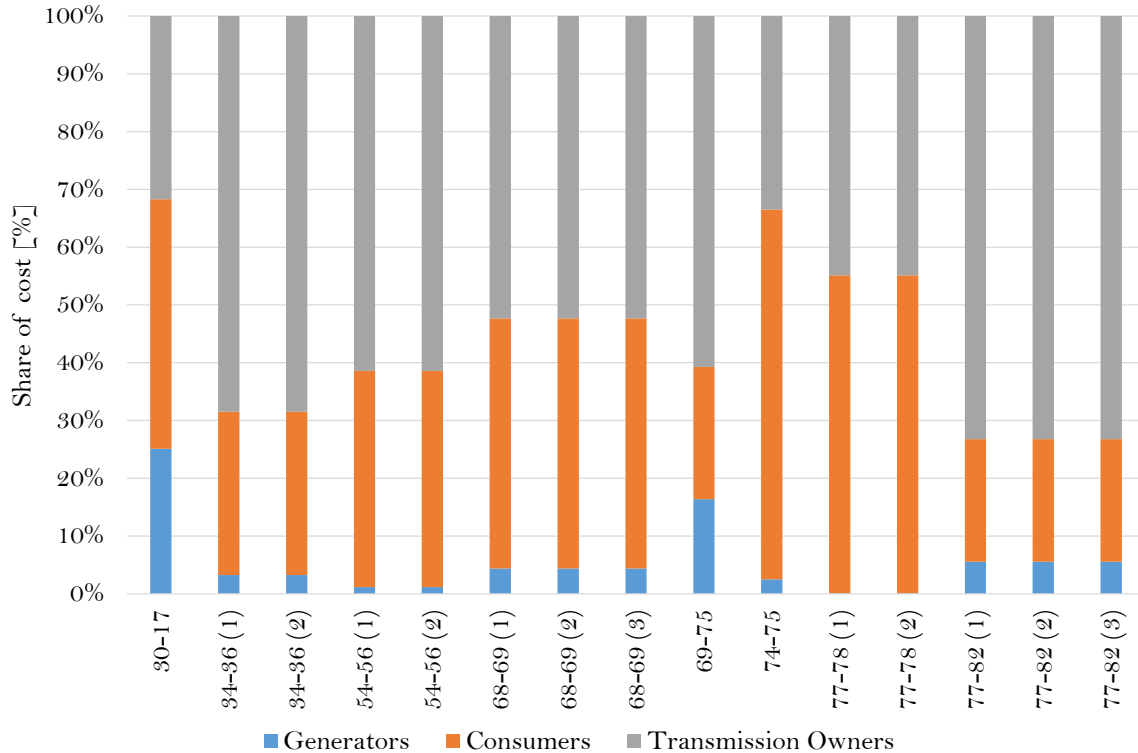

Fig. 4.7. Allocation of the costs of each expansion project, in percentage, to the different sets of network users considered (generators, consumers and TOs) without paying any compensation to the network users obtaining negative benefits from projects. Although aggregated in order to display the results, each network user is considered separately.

⁷⁸ As previously discussed, the method proposed is able to compute the negative benefits obtained by individual users from each expansion project. Therefore, it would be possible to compensate users obtaining negative benefits from each project. See section 4.3.5.2 for more details about this.

As displayed in this figure, the application of the “beneficiary pays” principle results in most of the expansion projects selected being mainly paid by consumers and TOs⁷⁹. Generators pay a small fraction of the costs of these projects and, in some cases, like projects 77-78 (circuits 1 and 2), they do not pay anything. For instance, according to these cost allocation results, consumers should pay 64% of the total cost of project 74-75, while generators would only pay 3% of the total cost of this project. These results seem to confirm that the consumers of the network have to pay the largest share of the costs of new projects. Nonetheless, one can realize that there are some exceptions to this general result. For example, generators should pay about 25% of the total cost of project 30-17.

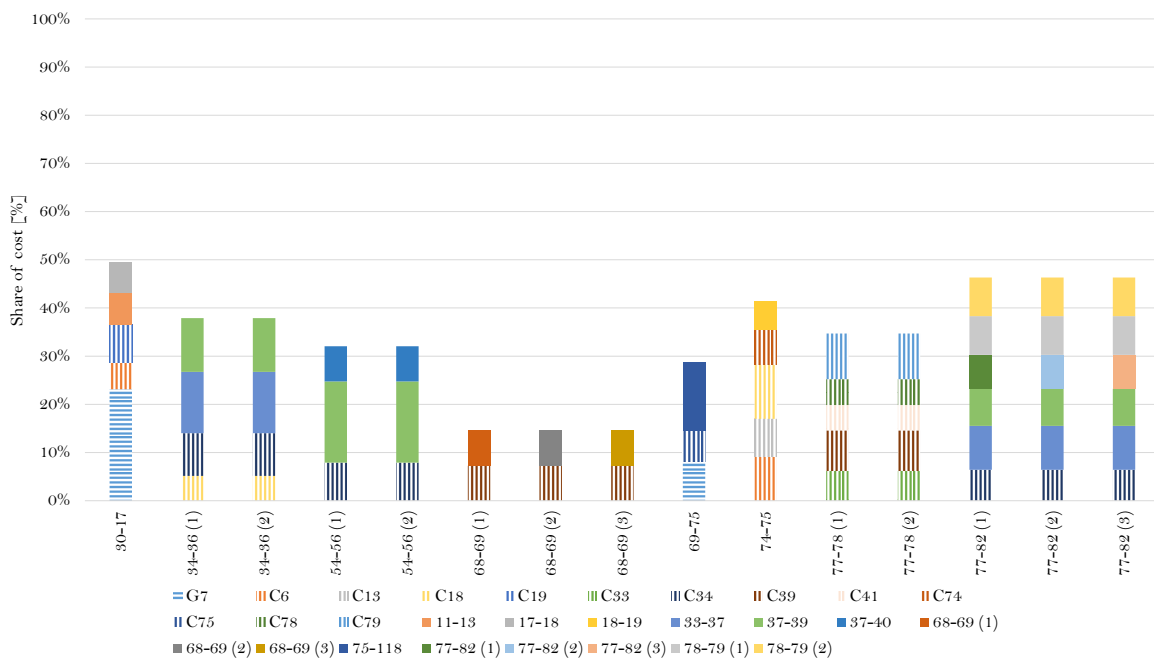

Fig. 4.8. Allocation of the costs of each expansion project, in percentage, to the individual network users when no compensation is being paid to the network users obtaining negative benefits from projects. Only network users having to pay 5% or more of the costs of each expansion project are listed here. Costs paid by generators are displayed with horizontal lines, costs paid by consumers are displayed with vertical lines and those paid by TOs are displayed with plain colours.

The graph in Fig. 4.8 aims to provide an idea of the allocation of the costs among the several individual network users. Since there are many users involved, for a better

⁷⁹ Please note that, in this case, the allocation of the costs computed does not depend on the value assumed for the benefits obtained by consumers from the electricity they consume since there is no ENS in the network.

visibility, only those paying more than 5% of the total cost of each project are included in the graph. The costs paid by different types of network users are represented differently in the graph: the share of costs paid by consumers are displayed in vertical lines, horizontal lines are used to represent the costs paid by generators and plain colors have been used for the costs to be paid by TOs. This figure shows that the cost of some projects should be paid by a multitude of network users, while other projects should be paid by very few users. For example, two specific network users should pay about 15% of the cost of project 68-69 (1), while other 211 network users should pay the remaining 85% of the cost of this project. On the contrary, five network users should pay about 50% of the cost of project 30-17.

In Fig. 4.8 it is also possible to see that generator “G7” should pay a relevant amount corresponding to a non-negligible fraction of the cost of project 30-17, since this generator is obtaining large benefits from this project (see Table 4.17). On the other hand, the consumers located in the same node as this generator (node 18) are being harmed by this project (obtain negative benefits from the project) and, then, must not pay any fraction of the project cost. As previously stated, network users must also be considered separately from others located within the same node, either generators or consumers, as well as from those of the same type in the system (other generators if the user concerned is a generator, or consumers if this user is a consumer). Allowing the generator in node 18 (“G7”) not to pay a fraction of the cost of the project 30-17 that is commensurate with the benefits it, at individual level, is expected to obtain from this project, just because other generators in the system, or those consumers in its same node, are being harmed by this same project, would render an inefficient –as well as unfair– locational signal⁸⁰, since agents in the system would be treated on a discriminatory basis.

4.3.5.2 Cost allocation at multi-system, or multi-country, level

Although cost allocation can be performed at individual user level, the cost of important expansion projects that are to be used, i.e. that are to benefit, several systems or countries in a region (such as the PCI projects in the EU) is usually allocated to countries, or regions, first, and not to individual users⁸¹. Normally, the cost of expansion projects is

⁸⁰ Sending the correct locational signals is important in order to make network users internalize in their investment decisions the network expansions costs they create. This should result in a more efficient operation of the system and expansion of the network. In the current context, with a lot of RES generation being (and forecasted to be) installed, this is especially important.

⁸¹ At least directly. Countries can then allocate the costs they have been assigned to individual users using their own cost allocation methods. This is the idea underlying the application of the ITC mechanism in the EU.

paid by those countries where the new transmission assets are going to be located, for example, on a 50%-50% basis if this is a project involving the construction of a transmission line crossing the border between the corresponding two countries (Diyun Huang et al. 2016). However, applying this rule results in some important projects, being largely beneficial for the whole region, not being built when the countries hosting the new transmission facilities oppose their construction due to the fact that these projects are expected to render large benefits to third countries in the region.

It is important to remark that countries (or RTO regions in the USA) normally have the capacity to decide, or block, the construction of expansion projects that are located in their territories. Thus, in this case, although fairness is still very important, it is key that the cost allocation method provides enough incentives to guarantee the deployment of expansion projects. There may be some cases where a regional authority can unblock the construction of the aforementioned projects. For instance, ACER can decide on the cost allocation of PCI projects when the corresponding national regulatory authorities affected by the construction of these projects, including those where the projects are to be deployed, do not agree on its cost allocation within six months (ACER 2013). However, the latter are exceptions, i.e. generally speaking, achieving the construction of the required new transmission facilities in a multi-system context requires making each system pay a fraction of the cost of each of the corresponding projects that is commensurate with the benefits this system is expected to obtain from this project. What is more, contrary to the case of a fully integrated system where authorities can decide over the expansion of the network in the full system, considering the payment of compensations to those systems negatively affected by new projects may be necessary.

Let us now consider that the power system in the case study considered is divided into three zones, as indicated in Fig. 4.2. These zones could represent several countries (like in the EU) or regions (like in the USA). In the following paragraphs, the case of some of the expansion projects selected as priority ones will be analyzed to identify the possible obstacles they could face to get the required permits for their construction. Here, I shall assume that the estimate of the benefits obtained by each of the three zones from each project, as computed using the benefit assessment method proposed here, is representative of the real benefits each zone is obtaining, and is in line with the estimates that authorities in each zone are making of these benefits. The benefits of each zone from a project are calculated as the sum of the benefits (positive and negative) obtained by the individual users located in each zone from that project. Afterwards, I shall compare several cost allocation arrangements for these projects regarding the consideration made in these arrangements of the negative benefits obtained by some zones from these projects (if compensations should be paid or not to these zones). This will allow to determine how the negative benefits obtained by some zones from a project should be considered when

allocating the cost of this project in order to achieve its undertaking. The benefits that network users in each zone, or benefits that each zone, are expected to obtain from each project are displayed in Fig. 4.6. Focusing on some specific projects, it is easier to see the difficulties that authorities may face in achieving the undertaking of these projects:

- Project 30-17. This is a project located in zone 1. As displayed in Fig. 4.6, zone 1 is the only one obtaining positive benefits from this project (the other zones are obtaining negative benefits). Then, zone 1 has strong incentives to build it. Assuming that this zone is the only one able to decide on the undertaking of this project, given that it is going to be deployed in its sole territory, project 30-17 should not face any difficulty to be deployed if benefits produced by it are computed by the existing zones according to the method proposed here.
- Project 74-75. This is also a project located within zone 1. However, contrary to what happens with project 30-17, according to the method here proposed, the zone that is mainly benefiting from this project is zone 3. Thus, the undertaking of this project could face some problems if zone 1 is paying the full project cost. These could be solved if zone 1 and zone 3 are paying fractions of the cost of the project that are roughly proportional to benefits they are obtaining from this project.
- Project 34-36 (1)⁸². This project is located in zone 2. Similarly to what happens with project 74-75, other zones than zone 2 are benefiting to a larger extent than the latter from this project. However, achieving the construction of this project is even more difficult, since, in this case, the zone where the project is located, zone 2, is obtaining negative benefits from it. Thus, zone 2 has no incentive to build this project (in fact, zone 2 has the incentive not to build it) and will block its construction unless zones 1 and 3 pay the full cost of the project and appropriately compensate zone 2 for the losses it will incur if this project is carried out.
- Project 77-82 (1)⁸³. Contrary to the projects previously considered, this is a project interconnecting two zones: zone 2 and zone 3, specifically speaking. In this case, zone 2 is not benefiting from this project, but zone 3 is obtaining a large benefit from it. Moreover, zone 1 is also obtaining positive benefits from this project. Under traditional cost allocation arrangements, zones 2 and 3 would share the costs of this project on a 50-50% basis. However, it is unlikely that zone 2 would accept this allocation of the project cost. Zone 2 would only accept undertaking this project within its territory if zone 1 and zone 3 pay the full project cost,

⁸² Project 34-36 (2) may also be considered here.

⁸³ Projects 77-82 (2 and 3) may also be considered here.

probably including in this cost all the negative impacts of any kind, like environmental ones, that zone 2 would suffer as a result of having the corresponding transmission assets placed in its territory.

Fig. 4.9 provides the allocation of the costs of the selected expansion projects to the considered zones if no compensation is paid to those zones obtaining negative benefits from each project (being negatively affected by it). The cost of each project to be paid by each zone is expressed as a percentage of the cost of this project. Fig. 4.10 shows the final net benefits obtained by each zone from each expansion project selected with this cost allocation scheme. The final net benefits of a zone from an expansion project are the benefits obtained by this zone from the expansion project minus the allocated cost of this project to this zone. This cost allocation solution would probably overcome the obstacles that could have been faced by some of the projects previously discussed if their cost had been paid by those zones where these projects are located. For instance, it would pave the way for the undertaking of the expansion project 74-75, because zone 3 would be paying most of the costs of this project according to this arrangement⁸⁴. However, the problems faced by some other projects to gather the required permits for their undertaking would not be solved. Thus, project 34-36 (1) would most probably not be carried out because no zone would be compensating the zone where the project is located for the negative benefits this zone is obtaining from the project (as can be seen in Fig. 4.6, this zone is having negative benefits from this project). The same happens for project 77-82 (1), since zone 2, which is incurring a small negative benefit, or loss, from this project, would not be compensated for this loss.

⁸⁴ Please note that the cost allocation here applied is not the one being currently employed in EU by ACER. The cost allocation method employed by ACER only considers cross-border projects.

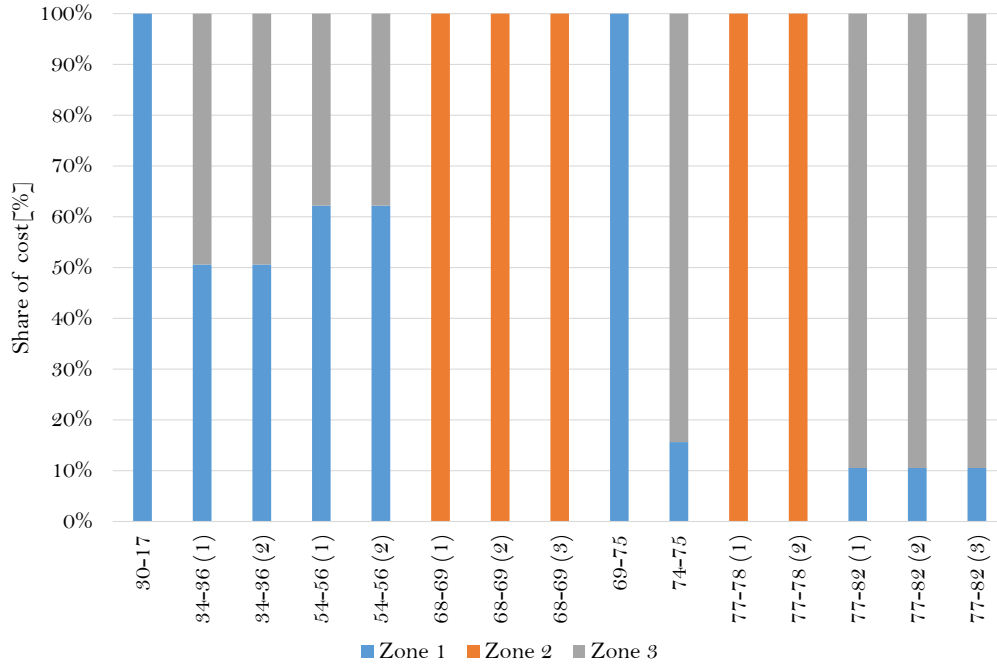

Fig. 4.9. Allocation of the costs of each expansion project, in percentage, to the zones defined in the power system, when no compensation is paid to the zones negatively affected by each project.

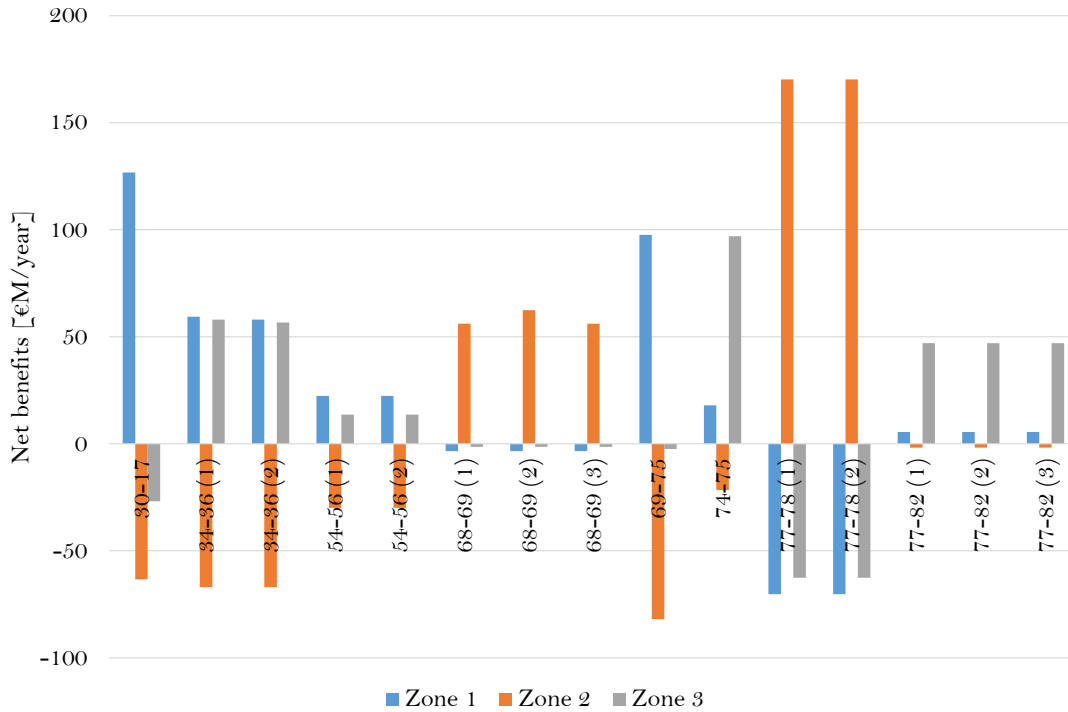

Fig. 4.10. Final net benefits obtained by each zone from each expansion project (benefits of the zone minus the cost allocated the zone) when no compensation is made to the zones negatively affected by expansion projects.

The “beneficiary pays” principle is applied now, at zone level, where zones obtaining negative benefits from an expansion project shall be compensated for the losses incurred. This criterion is similar to the “beneficiary pays” one applied by ACER when deciding on the allocation of the cost of PCIs when the countries in the IEM affected by these projects have not managed to agree on an allocation of their cost (ACER 2013). The method employed by ACER, called net benefit method, compensates systems negatively affected by a project obtaining the funds required to implement these compensations. These compensations are obtained from the payments made by those other systems that are earning substantial positive benefits from the project. However, the ACER method does not apply to every expansion project of a cross-border nature, but only to those that cross a certain border.

In the analysis presented here it is assumed that any zone negatively affected by the undertaking of a project (obtaining negative benefits from this project) must be paid a compensation equal to the negative benefits, or losses, this project is causing this zone to incur. The compensations to be received by those zones negatively affected by each project should be paid by those other zones benefiting from this project proportionally to the benefits the latter zones are obtaining from the project. Then, compensations to be received by the former zones plus the cost of the project itself make the full amount, or augmented cost, to be collected from the zones benefiting (positively) from the project. Fig. 4.11 shows the allocation of the cost (augmented cost in this case) of the expansion projects being analyzed taking into account the compensations to zones negatively affected by projects, as just mentioned. For each project, the fraction of the augmented cost of this project, including the compensations it gives raise to, to be paid by each system zone is provided as a percentage of this cost. The negative figures indicate that a compensation of the corresponding size is being paid to the corresponding zone.

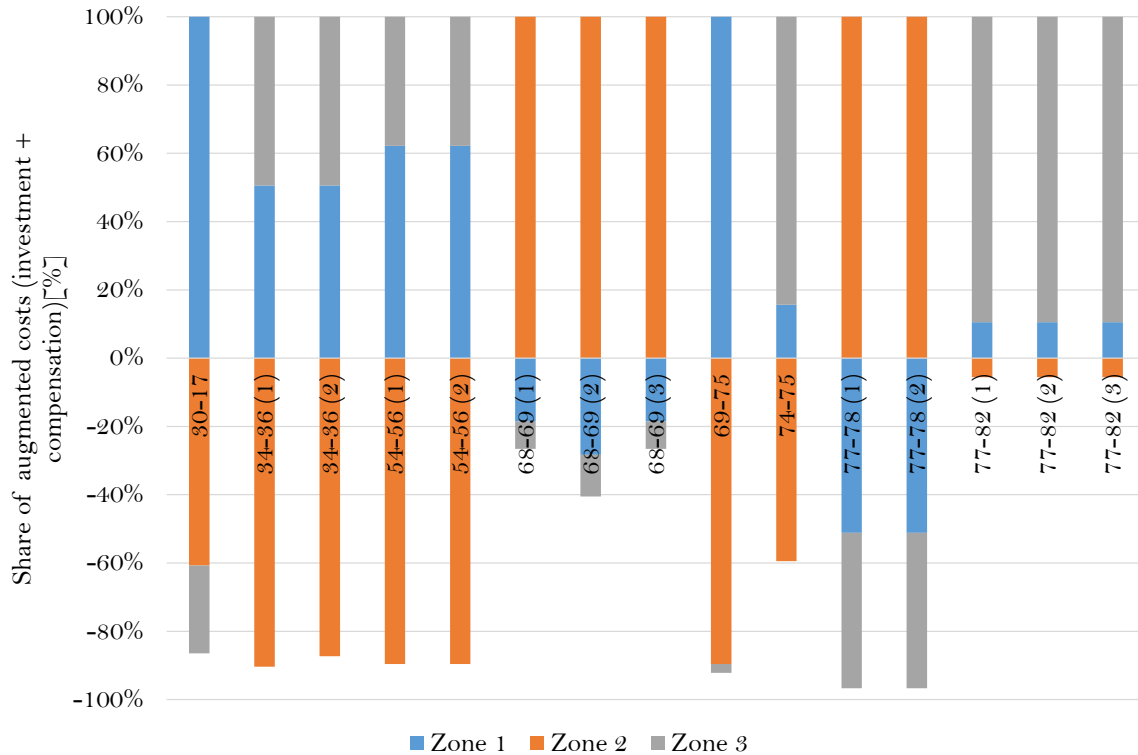

Fig. 4.11. Allocation of the costs of each expansion project to the zones defined in the power system, [% of the augmented costs (including compensations) of each project]. Negative figures indicate that a compensation of the corresponding magnitude is being paid to the corresponding zone.

The application of this last cost allocation arrangement could be a step forward that should overcome most of the barriers encountered by expansion projects subject to the arrangements previously discussed. Resulting from this cost allocation scheme, the final net benefits obtained from a project by those zones negatively affected by this project would be zero after these compensations are paid. This can be seen in Fig. 4.12, which indicates the final net benefits obtained by each zone from each project once the compensations have been paid. Consequently, these zones should not oppose the undertaking of the project. According to this scheme, zone 2 would be paid a compensation for the undertaking of expansion projects 34-36 (1) and 77-82 (1) (see Fig. 4.11). Thus, this zone would not have any incentive to block the construction of these projects, which, remember, are going to be located in its territory. However, when countries negatively affected by the undertaking of a project do not have veto power to block it (because they do not lay within their territory, for example), those promoting their construction may reject paying a compensation to the former, who would increase the cost of the project for them. Thus, in reality, a hybrid scheme may need to be adopted where negative benefits (compensations) are only considered in network cost allocation

arrangements when countries harmed have the possibility of hindering the construction of the needed reinforcements.

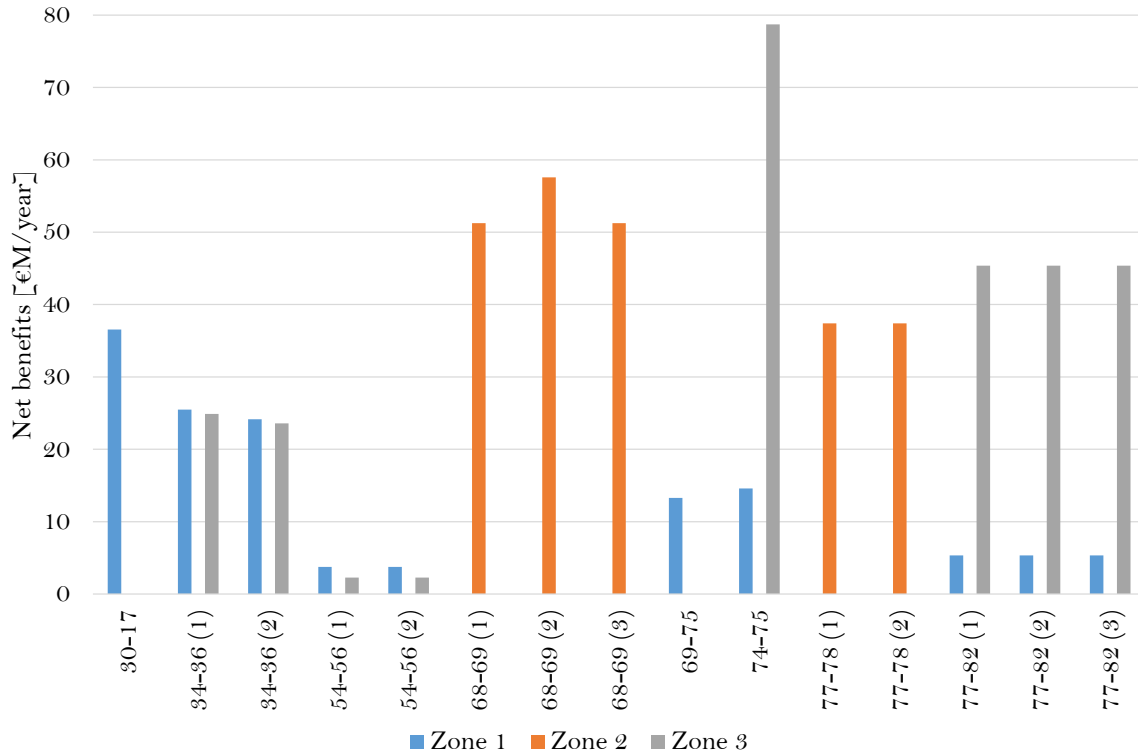

Fig. 4.12. Final net benefits obtained by each zone from each expansion project (benefits of the zone minus the cost allocated to it) when the cost allocation scheme considers that compensations are paid to the zones obtaining negative benefits from this project.

4.4 CONCLUSIONS

This chapter includes several case studies of different sizes that are discussed in order to show the applicability of the method proposed to each of them and demonstrate how this method performs compared to previously existing ones according to the features that any sound benefit assessment method should have (as discussed in previous chapters).

The method here proposed has been applied, first, to a 9-bus power system. Its performance has been compared to that of two other methods currently in use in Europe for the cost-benefit analysis of network expansion projects: the TOOT and PINT ones. The fact that the method discussed in the literature that is based on the computation of the Shapley value of each project could not be applied even in this case study, of a relatively small size, shows one of the most relevant drawbacks of this method: its

computational burden. Given that the 9-bus case study is of a relatively small size, numerical results obtained from the application of the AS, TOOT and PINT methods are easy to interpret. This makes it possible to **identify some of the advantages and drawbacks of each method** (previously discussed in chapters 2 and 3 from a more conceptual, or theoretical, point of view).

A second case study, considering a 118-bus power system, has been employed in order to demonstrate the applicability of the method proposed to a larger case of a real-life size and its usefulness to obtain results that can be valuable in real-life decision making processes. This method is, therefore, applied to support the planning of the expansion of the transmission grid and the regulation of the transmission activity, including, largely, the allocation of the cost of transmission assets. This method is applied, together with the PINT and TOOT methods, to estimate the overall benefits produced by expansion projects and build a benefit-based ranking of these projects (similar to the PCI list defined by ACER and the European Commission in the EU). The results obtained show that **net benefits produced by priority expansion projects** within large-scale systems that are **selected using the proposed method tend to be larger than those** benefits produced by priority projects selected **using other methods**. Focusing on the expansion projects selected as priority ones with the proposed method (AS), I have afterwards **identified the main objective (or function) of each one** of these projects. This identification is carried out by computing the amount of benefits of each of several types, comprising the reduction of system operation costs, the integration of the production of RES generation, and the reduction of CO₂ emissions, that are expected to be produced by each project according to the AS method developed and proposed in this thesis. Based on these, I have concluded that there are some projects that are mainly producing benefits of one single type, while other projects can be categorized as multi-benefit projects because they produce significant amounts of several types of benefits.

Last, and most importantly, **the benefits that each individual network user, and each of several groups of users termed here zones, are expected to obtain from each of the selected projects** according to the proposed benefit assessment method **are computed**. Based on these, and **according to the “beneficiary pays” principle, the cost of each selected expansion project to individual network users and zones has been allocated**, i.e. the level of the payment that each agent or zone should make in relation to each project is determined. The benefits computed according to the proposed method are assumed to be representative of the real ones obtained by users from these projects. Besides, the benefits obtained by network users and zones from each project according to the method proposed are also assumed to be coincident with the estimates that these network users and zones are making of the benefits they will obtain from this project. Then, the proposed cost allocation method is deemed to be fair and efficient and lead to a

satisfactory development of the network. I have tested several variants of the proposed project cost allocation arrangements regarding the consideration made in them of the negative benefits that network zones are expected to obtain from projects. Based on the analysis carried out, I have concluded that, at individual network user level and within a perfectly integrated system, probably, network users should not be compensated for the negative benefits they obtain from projects by those network users obtaining positive benefits from them. However, at country, or zone level, at least those zones that have the ability to block the undertaking of the required projects should be compensated for the negative net benefits they are expected to obtain from them if these projects, which are beneficial for the region as a whole, are to be deployed.

Based on the numerical results computed, one may conclude that **the Aumann-Shapley method here proposed has some relevant advantages over other methods** proposed in the literature. The reader should note that **the drawbacks of TOOT, PINT, and Shapley methods can only be expected to become more relevant the larger the size of the power system –and the corresponding expansion plan– analyzed.**

Chapter 5

Conclusions, contributions and future research

The last chapter of this document is committed, in the first place, to summarize the main conclusions that resulted from the research carried out in this thesis work. After presenting the main conclusions, the original contributions made to the state of the art during the development of the thesis are discussed. Finally, some lines of research that will be worth being further explored in the future are identified.

5.1 SUMMARY AND CONCLUSIONS

The international community has agreed to achieve a drastic reduction in CO₂ emissions, together with a huge growth in the energy produced with renewable generation technologies. The installation of the amount of RES capacity necessary will require large network investments to integrate this renewable energy into the power system. Therefore, expanding the transmission network is a necessary step in order to accomplish the international goals of RES production and CO₂ emission reduction. However, as recognized by the EU and US authorities, there are serious risks that the required network infrastructures are not deployed.

In order to manage these risks, the authorities in the EU and the USA have changed the framework that regulates the expansion of the network. Thus, a dedicated regulatory framework has been established in Europe in order to incentivize, or guarantee, the deployment of important expansion projects. Besides, the method employed to allocate the infrastructure costs of these projects has also been modified in both the EU and the USA. The regulation recently enacted in the EU and the USA, both to select the priority projects and to determine the allocation of their cost to the network users or systems, requires estimating correctly the benefits and beneficiaries produced by individual expansion projects within an expansion plan, or group of projects. Nonetheless, this a difficult task that remains largely unexplored in the literature. This thesis, therefore, proposes a method to determine the global benefits produced by the individual expansion projects comprised in an expansion plan and which benefits are to be obtained by each network user, country, or state, from each project.

The main methods already proposed for the assessment of the benefits of projects are reviewed first: TOOT, PINT and Shapley. Then, the main characteristics that should be featured by a method to determine correctly the benefits and beneficiaries produced by expansion projects are identified and discussed. These characteristics include:

- a) The fact that the benefits computed take interactions of expansion projects into account.
- b) The ability not to assume a specific order of deployment of projects, which involves that the benefits computed do not depend on the order of deployment of the projects.
- c) The independence of the benefits assigned to expansion projects of how the rest of investments in the expansion plan are grouped into other projects.
- d) The fact that it is applicable to real-life systems.
- e) The fact that this method is easy to understand.

The analysis of the existing methods in the light of the characteristics identified show that none of these methods features most of the characteristics described. In fact, the drawbacks of TOOT, PINT and Shapley methods can only be expected to become more relevant the larger the size of the power system –and the corresponding expansion plan– analyzed.

The proposed method relies on the idea that projects within an expansion plan should be assessed together with the other expansion projects in the plan, and not on an individual basis. Therefore, the method proposed is based on a cooperative game theory solution concept: the Aumann-Shapley one. The Aumann-Shapley game formulated takes network expansion projects as the players of the game, while the characteristic function to be allocated represents either the global benefits obtained by the system from these projects, or the benefits reaped by individual network users, or groups of users. I have also focused on allocating the several types of benefits that can be considered in the economic dispatch. The proposed method is, then, particularized to address each objective pursued: computing the global benefits of projects, the set of agents benefiting from them, or the contribution of each project to the type of benefits obtained by each network user or group of users.

As illustrated with the help of an example, the method proposed features most of the desirable characteristics of a benefit allocation method, which makes it coherent with the technical and economic principles ruling the expansion of the network. Although it is not completely intuitive or easy to understand, the implementation proposed of this method has a clear interpretation, since it simulates the effect on the benefits of network users of the gradual deployment of the expansion plan, or group of projects, considered.

Several case studies, of different sizes, have been used to show the applicability of the method proposed and compared it to others. The method proposed is compared to currently applied methods for the cost-benefit analysis of projects using a 9-bus power system. This is a relevant application of the method in Europe. The results computed have allowed to identify some of the advantages and drawbacks of the proposed method, as well as those of other methods. A larger case study –118-bus power system– has been employed to show the applicability of the method proposed to support the expansion of the network and its regulation in a case of a real-life size. More specifically, it is used i) to build a list of priority projects similar to that in the PCI list defined by ACER and the European Commission in the EU (a benefit-based ranking); ii) to identify the main objective of the –previously defined– priority projects (to help authorities and stakeholders to understand them); and iii) to allocate the costs of these priority projects to network users, or groups of them in this case, using the “beneficiary pays” principle. The cost of each selected expansion project is allocated to individual network users and zones. Moreover, several options for the implementation of the cost allocation method proposed

are considered regarding the treatment, or consideration, made of the negative benefits produced by each project when allocating its cost. Based on the analysis performed, I have concluded that, in a perfectly integrated system, network users should probably not be compensated for the negative benefits that expansion projects are producing for them. At a country or zone level, this may be different. Zones, or countries, having the right to block the deployment of the selected expansion projects should be probably compensated for the negative benefits they obtain as a result of the deployment of these projects in order to guarantee the deployment of these projects (which are beneficial for the region as a whole).

As a conclusion, it can be said that the Aumann-Shapley method here proposed has some relevant advantages over other methods proposed in the literature. Moreover, the drawbacks of TOOT, PINT and Shapley methods are expected to become more relevant when analyzing larger power systems and their corresponding expansion plans.

5.2 CONTRIBUTIONS

This thesis proposes a novel approach to estimate the benefits and beneficiaries of expansion projects within a real-life scale expansion plan based on the Aumann-Shapley concept. The development of this final objective has yielded to different contributions:

- Identification and discussion of the properties that should be enjoyed by a method to assess the benefits –and beneficiaries– of the network expansion projects within a plan, or group of projects, and analysis of existing methods in the light of these properties.
- Providing a method to assess the benefits and beneficiaries of expansion projects within a plan, or group, that fulfils the properties identified. Therefore, this method is consistent with the technical and economic principles that rule the expansion of the network. The method proposed is particularized for different specific applications:
 - Estimate the global system economic benefits produced by individual expansion projects.
 - Determine the individual network users benefiting from expansion projects.
 - Calculate the benefits of each of several kinds, including the market or dispatch ones, that each individual network user, or group of them is expected to obtain from each expansion project.
- Formulation of the Aumann-Shapley approach to determine the benefits obtained by the system and by individual users from expansion projects. This contribution involves:

- Formulation of the AS approach to consider expansion projects as players of the cooperative game.
- Formulation of the AS approach to the computation of the continuous benefits obtained by individual users from expansion projects, which has never been done. Continuous benefits are those benefits of the deployment of expansion projects that are a continuous function of the size of these projects.
- Adaptation made of the conventional AS approach to allocate to individual network users the discrete benefits produced by expansion projects. The discrete benefits of individual projects are those that do not evolve continuously with the size of projects but are realized all of a sudden once one or several of these projects have reached a certain size. Here, a method to determine which specific expansion projects are responsible of the discrete changes occurring in the benefits that individual network users obtain from the deployment of the plan was devised.
- Implementation of the AS method in a computationally efficient way, which allows one to apply this methodology to large-scale systems and expansion plans⁸⁵.
- Application of the proposed method to two case studies to illustrate the applicability of the method and its properties:
 - A small case study is used to describe the desirable properties of a benefit assessment method and illustrate the application of the method proposed.
 - A larger case study is analyzed to show the applicability of the proposed method to systems of a large size, as well as the possible real-life applications of these results.

The work developed in this thesis has resulted in two journal papers (one published and one under review):

- F. Banez-Chicharro, L. Olmos, A. Ramos, and J. M. Latorre, “Estimating the benefits of transmission expansion projects: An Aumann-Shapley approach,” *Energy*, vol. 118, pp. 1044–1054, Jan. 2017.
- F. Banez-Chicharro, L. Olmos, A. Ramos, and J. M. Latorre, “Beneficiaries of Transmission Expansion Projects of an Expansion Plan: An Aumann-Shapley Approach,” *Applied Energy*, vol. 195, pp. 382-401, June 2017.

⁸⁵ The proposed methodology is implemented in the TEPES model.

Additionally, during the development of the thesis, I have also participated in different articles (two published and two under review), a book chapter and several conferences related to the power sector.

Journal articles:

- S. Lumbreras, A. Ramos, and F. Banez-Chicharro, “Optimal Transmission Network Expansion Planning in Real-Sized Power Systems with High Renewable Penetration,” *Under Rev. Electr. Power Syst. Res.*, 2017.
- S. Lumbreras, A. Ramos, F. Banez-Chicharro, L. Olmos, P. Panciatici, C. Pache, and J. Maeght, “Large-scale Transmission Expansion Planning: from zonal results to a nodal expansion plan,” *Under Rev. IET Gener. Transm. Distrib.*, 2017.
- J. P. Chaves-Avila, F. Banez-Chicharro, and A. Ramos, “Impact of support schemes and market rules on renewable electricity generation and system operation: the Spanish case,” *IET Renew. Power Gener.*, Jul. 2016.
- F. Banez-Chicharro, J. M. Latorre, and A. Ramos, “Smart charging profiles for electric vehicles,” *Comput. Manag. Sci.*, Jul. 2013.

Book chapter:

- A. Ramos, K. Dietrich, F. Banez-Chicharro, L. Olmos, and J. M. Latorre, *Analysis of the impact of increasing shares of electric vehicles on the integration of RES generation.* 2014.

Conferences:

- J. P. Chaves-Avila, F. Banez-Chicharro, K. Dietrich, and A. Ramos, “Implications from changing the priority dispatch for intermittent energy sources to a market based approach: application to the Spanish case,” in *14th International Workshop on Large-scale Integration of Wind Power into Power Systems as well as on Transmission Networks for Offshore Wind Power Plants*, 2015.
- S. Lumbreras, A. Ramos, L. Olmos, F. Echavarren, F. Banez-Chicharro, M. Rivier, P. Panciatici, J. Maeght, and C. Pache, “Network partition based on critical branches for large-scale transmission expansion planning,” in *2015 IEEE Eindhoven PowerTech, PowerTech 2015*, 2015.
- F. Banez-Chicharro, J. M. Latorre, and A. Ramos, “Smart charging profiles for electric vehicles,” in *9th International Conference on Computational Management Science*, 2012.

- A. Ramos, J. Latorre, F. Bañez-Chicharro, A. Hernandez, G. Morales-España, K. Dietrich, and L. Olmos, “Modeling the operation of electric vehicles in an operation planning model,” in 17th Power Systems Computation Conference - PSCC’11, 2011.

5.3 FUTURE RESEARCH

The development of this thesis has led to different lines of future research that may provide very interesting results. This section summarizes them and explains their possible relevance.

5.3.1 Benefits estimation

A natural continuation of this work is the extension of the method proposed to consider other types of benefits besides market based ones. The method here developed has only been applied in this thesis work to compute the benefits produced in the dispatch (in particular, those that can be considered market benefits). But other type of benefits may be also considered, e.g. the reduction of market power brought about by new projects, or public policy benefits of these projects. In fact, the adaptation made of the Aumann-Shapley game to identify the specific expansion projects responsible of discrete changes occurring in the market benefits of network users opens the door to further research in this direction.

The formulation employed in this thesis does not consider any uncertainty. Therefore, another possible continuation of the research here presented involves incorporating the existing uncertainty about the future development of the system and the conditions applying in it in the assessment of the benefits produced by projects.

5.3.2 Definition of expansion projects

The final objective pursued in this thesis is to compute the benefits that each network user, or group of network users, is expected to obtain from each expansion project. Therefore, properly defining expansion projects is central to accurately estimating the benefits produced by each of these projects.

The project definition refers to the delineation of the object to be evaluated. But, due to the strong interactions existing among the several network reinforcements to be deployed, the definition of the boundaries of each project is not straightforward (von der Fehr et al. 2013). The definition, or identification, of a project involves determining a set of reinforcements, an object, that make a self-sufficient unit of analysis (Florio et al. 2008). Traditionally, in transmission expansion planning, TSOs have proposed groups of reinforcements that were linked to specific network needs. Thus, the rationale for these reinforcements and the relationship among them were relatively easy to understand.

However, when transmission expansion planning is performed for larger regions, where several TSOs are involved, the relationships and interactions among the reinforcements proposed by all of them are more difficult to assess. This is the current situation in the EU and the USA, where there are mandates to perform the transmission expansion planning for the whole region comprising several traditionally integrated systems where national/local TSOs operate. Moreover, due to the absence of TSOs with experience on the functioning of the whole region, there is a growing need for automatic candidate project proposal mechanisms (Lumbreras et al. 2014).

There is not much research in the electricity sector about this topic. ENTSO-E has aimed to address this issue through the CBA methodology proposed in (ENTSO-E 2013). In (Lumbreras et al. 2014), the authors propose to use a power flow based approach for determining the rationale behind individual transmission reinforcements and the relationships among them. This approach involves analyzing the variation in the power flow through the circuit of each reinforcement when a second reinforcement is deployed (assuming that the rest of the transmission expansion plan is deployed).

Following the approach employed in (Lumbreras et al. 2014), I have applied hierarchical clustering to identify preliminarily the interdependence relationships existing among candidate reinforcements. This is carried out automatically by assessing the changes taking place in the line flows in the network for each of the expansion plans computed in the several iterations of the algorithm implemented for the computation of the optimal expansion plan⁸⁶. The results obtained so far following this approach seem promising, but further research is required in order to arrive at a conclusive outcome.

Graph theory can also be used to identify relationships existing among transmission reinforcements, in the same way it is currently applied to the analysis of social networks.

5.3.3 Cost allocation

The methodology proposed has been applied to compute the benefits that each individual network user, or each zone (country), are expected to obtain from expansion projects. Using these results, the “beneficiary pays” principle is applied to allocate the costs of those expansion projects.

⁸⁶ In TEPEs, which is the network expansion model used in this thesis work, one of the solution methods employed is Benders decomposition. This method solves the transmission expansion planning problem in several iterations. These iterations provide different solutions of the problem, i.e. different decisions about transmission investments, and their performance. Thus, each of these solutions can be interpreted as an alternative expansion plan.

Other methods have been previously applied to determine the allocation of the costs of the expansion projects. Thus, it will be very interesting to compare the results provided by the method proposed in this thesis to other cost allocation methods, for example, the average participation or marginal participation methods. In particular, it will be very interesting to compare the allocation of the cost of projects computed according to the method proposed with that provided by other methods that are also based on the Aumann-Shapley concept. When Aumann-Shapley has been directly applied before to allocate the costs of transmission assets, the players of the game considered in previous works have always been the generators and consumers of the power system, and not the expansion projects. In many of these previously existing methods, the split of the network costs between generators and consumers needs to be decided *ex-ante*, i.e. before allocating the cost of each project to the network users. Therefore, a very interesting piece of research could be focused on computing the split of the network cost between generators and consumers decided *ex-ante* for which the allocation of the cost of the network expansion projects according to the any previously existing method leads to similar results to those produced by the method proposed in this thesis.

In the large case study discussed in Chapter 4 of this thesis, a brief discussion of the effect of the consideration made of the negative benefits produced by the expansion projects on the allocation of the cost of these projects is included. However, further discussing this topic may most probably be worthy.

5.3.4 Priority expansion projects

The methodology proposed in this thesis may be applied to support the planning of the expansion of the transmission grid and its regulation. One of its direct applications is to rank the expansion projects based on their benefits and select the ones that should be deployed with the highest priority.

The methodology proposed in this thesis relies on the Aumann-Shapley approach, which is a cooperative game theory solution concept. Nevertheless, there are other solution concepts that could also be researched for this purpose. The Shapley-Shubik index, for example, was formulated to measure the importance of players in a voting game. Thus, it has been applied to analyze the distribution of the voting power under different rules in the EU Council. This method can be used to identify the importance of each expansion project according to the minimum percentage of the potential benefits of the expansion plan that could be ensured under any circumstances.

Moreover, other approaches related with data analysis techniques may also be applied to identify the priority projects. For instance, decision trees could be a very interesting approach. This method could employ the intermediate results obtained in each iteration of

the application of an iterative algorithm for the computation of the optimal expansion plan⁸⁷ to identify those projects that are most important to achieve a good expansion plan.

⁸⁷ Please see footnote 86.

Appendix A

Sensitivities of system variables and dual variables

The aim of this appendix is to provide the theoretical background to the computation of the sensitivities of system variables employed in the methodology proposal of Chapter 3.

A.1 INTRODUCTION

The application of the method described in Chapter 3 relies on the use of the marginal changes, or sensitivities of the production of generation units, $\frac{\partial gp_g}{\partial l(ij)}$, the energy not supplied of consumers, $\frac{\partial ens_c}{\partial l(ij)}$, the power flow through lines, $\frac{\partial f_{l'}}{\partial l(ij)}$, and the marginal price of nodes, $\frac{\partial \mu_n}{\partial l(ij)}$, with respect to the size of expansion projects. The production of generation units, gp_g , the ENS of consumers, ens_c , and the power flow through lines, $f_{l'}$, are part of the system variables of the economic dispatch and optimal power flow problem. The marginal price of nodes, μ_n , is also part of the dual variable of this same problem.

This appendix describes the approach followed to analytically compute these marginal changes from a marginal increase in the size of asset l due to the implementation of an elemental expansion project. Please note that this is the same as computing the sensitivities of these variables with respect to the size of asset l in the different steps k of application of the AS algorithm⁸⁸.

As previously described⁸⁹, we can consider several situations when splitting expansion projects. These situations are summarized in Table A.1 based on the type of expansion project considered.

Table A.1. Situations considered for the splitting of expansion projects

Type of expansion project	Parameters of expansion projects	Relationship
AC	Capacity and admittance affects system operation	Related/Independent
HVDC	Only capacity affects system operation	-

Thus, the sensitivities of the variables need to be calculated with respect to increases in the transmission capacity, in the admittance, or both of them.

For the sake of simplicity, the economic dispatch problem presented in section 3.2.3 of Chapter 3 is here represented as a standard linear optimization problem, see (A.1). Inequality constraints –like the power flow capacity of the lines and the maximum

⁸⁸ This is further explained in Chapter 3.

⁸⁹ Please, see section 3.2.4 in Chapter 3 for more details.

capacity of generation units– are transformed to equality constraints by including their corresponding slack variables.

$$\begin{aligned} \min \quad & Cx \\ & Ax = b \\ & l \leq x \leq u \end{aligned} \tag{A.1}$$

where C is the cost coefficients vector of the objective function, A is the coefficient matrix of the constraints, b is the independent terms vector of the constraints, and l and u are the lower and upper bound vectors of the system variables. The optimal solution of the problem may be represented as $x = (x_B \ x_{Nl} \ x_{Nu})$, where x_B are the basic variables, and x_{Nl} and x_{Nu} are the non-basic variables at the lower and upper bounds, respectively⁹⁰. These variables are non-basic ones because the level of these variables is in their corresponding bounds (upper and lower). Then, matrix A may be decomposed into $A = (B \ N_l \ N_u)$, where matrix B is the basis matrix and N_l and N_u are the non-basis matrixes (lower and upper, respectively).

The optimal solution of the linear optimization problem, in (A.1), must comply with the constraints in (A.2).

$$[B \ N_l \ N_u] \begin{bmatrix} x_B \\ x_{Nl} \\ x_{Nu} \end{bmatrix} = b \tag{A.2}$$

The dual variables of the constraints of the problem, π , for the optimal solution are computed as in (A.3).

$$\pi = (B^{-1})^t c_B \tag{A.3}$$

where c_B is the cost coefficients vector of the basic variables in the objective function.

The following sections analyze the sensitivities of the system operation variables and dual variables with respect to changes in the independent term, or right hand side (RHS) term, of a constraint, and with respect to changes in the coefficient of a constraint. Note that a change in the capacity of an asset affected by an expansion project involves a change in the RHS term of a constraint (vector b), while a change in the admittance an asset affected by an expansion project involves a change in the coefficients of the constraints (matrix A).

⁹⁰ In fact, not only the optimal solution of the problem may be represented with this structure.

A.2 SENSITIVITIES OF SYSTEM VARIABLES AND DUAL VARIABLES WITH RESPECT TO CHANGES IN THE CAPACITY OF ASSETS

A change in the capacity of a transmission asset affected by the deployment of an expansion project implies a change in the independent term, or RHS term, Δb , of the power flow constraints (see equation (3.5) in Chapter 3). In this case, matrix A does not change, which means that matrixes B , N_l and N_u do not change either, and then, the basis of the system remains the same. This implies that non-basic variables, x_{Nl} and x_{Nu} , remain at one of their limits (upper or lower one, depending on the variable concerned). Therefore, the sensitivity of these variables with respect to a marginal change in the RHS term of a constraint, $S_{x_{Nl}}$ and $S_{x_{Nu}}$, is equal to the changes in the binding upper or lower bounds of these variables, Δl_{Nl} or Δu_{Nu} , as indicated in (A.4)-(A.5)⁹¹.

$$S_{x_{Nl}} = \Delta l_{Nl} \quad (\text{A.4})$$

$$S_{x_{Nu}} = \Delta u_{Nu} \quad (\text{A.5})$$

The level of the basic variables may also change as a consequence of a change in the RHS, or independent, terms. The sensitivity of these variables, x_B , with respect to changes in vector b can be computed as in (A.6).

$$S_{x_B} = B^{-1} \cdot [\Delta b - N_l \cdot \Delta l_{Nl} - N_u \cdot \Delta u_{Nu}] \quad (\text{A.6})$$

As stated, a marginal change in the vector of RHS terms of constraints, Δb , does not result in a change of the basis of the optimal solution of the problem, since it does not affect matrix B . Therefore, the dual variables of the problem do not change either (see equation (A.3)). In this case, the sensitivity of the dual variables, i.e. the energy prices, with respect to a marginal change in the capacity of an asset is zero.

A.3 SENSITIVITIES OF SYSTEM VARIABLES AND DUAL VARIABLES WITH RESPECT TO CHANGES IN THE ADMITTANCE OF ASSETS

A change in the admittance of a transmission asset affected by the deployment of an expansion project implies a change in the coefficients of the constraints that represent the Kirchhoff's second law (see equation (3.4) in Chapter 3). A marginal change in the coefficients of the constraints of the problem, ΔA , can be represented as $\Delta A =$

⁹¹ By definition, the value of non-basic variables in the optimal solution is in their limits. Therefore, a change in its limits would provoke the same change in its value.

$(\Delta B \ \Delta N_l \ \Delta N_u)$. Then, changes in the level of system variables resulting from the former can be computed according to the set of equations in (A.7).

$$[B + \Delta B \quad N_l + \Delta N_l \quad N_u + \Delta N_u] \begin{bmatrix} x_B + S_{x_B} \\ x_{Nl} + S_{x_{Nl}} \\ x_{Nu} + S_{x_{Nu}} \end{bmatrix} = b \quad (\text{A.7})$$

If the marginal change in matrix A , ΔA , does not result in a change in the basis of the optimal solution of the economic dispatch (the set of basic variables for the optimal solution does not change), the sensitivity of non-basic variables is zero, since upper and lower bounds of variables remain the same. Then, subtracting (A.7) from (A.2) and operating the resulting equation one can obtain the expression in (A.8) for the sensitivity of basic variables with respect to an increase in matrix A .

$$S_{x_B} = -[B + \Delta B]^{-1}[\Delta B \quad \Delta N_l \quad \Delta N_u] \begin{bmatrix} x_B \\ x_{Nl} \\ x_{Nu} \end{bmatrix} \quad (\text{A.8})$$

From (A.3), one can deduce the expression relating a change in the basis matrix, B , to the resulting change in the dual variables. However, a change in the non-basis matrixes, N_l and N_u , does not affect dual variables, see (A.9).

$$S_{\pi} = ((B + \Delta B)^{-1} - B^{-1})^t c_B \quad (\text{A.9})$$

In the economic dispatch problem, a change in the admittance of a transmission asset caused by the deployment of an expansion project always affects the basis matrix, since the admittance of a transmission asset is weighting the voltage angle variables for the two end nodes of this asset in constraints representing the second law of Kirchhoff, see equation (3.4) in Chapter 3. Please, note that node voltage angle variables are, by definition, basic variables (except for the case of the slack node, whose voltage angle is pre-set).

A.4 SENSITIVITIES OF SYSTEM VARIABLES AND DUAL VARIABLES WITH RESPECT TO CHANGES IN THE CAPACITY AND THE ADMITTANCE OF ASSETS WHEN THEY ARE RELATED THROUGH A ONE-TO-ONE CORRESPONDENCE

If the capacity and admittance of transmission expansion projects, and the reinforcements associated with them, are related through a one-to-one correspondence, the deployment of an expansion project would imply the change in both the independent term, b , of the power flow constraints and in the coefficients of the constraints that represent the Kirchhoff's second law (see equations (3.4)-(3.5) in Chapter 3). Then, changes in the level of

system variables resulting from the former can be computed according to the set of equations in (A.10).

$$[B + \Delta B \quad N_l + \Delta N_l \quad N_u + \Delta N_u] \begin{bmatrix} x_B + S_{x_B} \\ x_{Nl} + S_{x_{Nl}} \\ x_{Nu} + S_{x_{Nu}} \end{bmatrix} = b + \Delta b \quad (\text{A.10})$$

As we are performing marginal changes, we can assume that the basis of the optimal solution has not changed. Therefore, the level of non-basic variables remains in its upper and lower bounds, see (A.4)-(A.5).

Formulating again (A.2), the sensitivity of basic variables with respect to the change in both the matrix A and the independent term b , can be calculated using (A.11).

$$S_{x_B} = [B + \Delta B]^{-1} \left\{ \Delta b - [\Delta B \quad \Delta N_l \quad \Delta N_u] \begin{bmatrix} x_B \\ x_{Nl} \\ x_{Nu} \end{bmatrix} - [N_l + \Delta N_l \quad N_u + \Delta N_u] \begin{bmatrix} \Delta l_{Nl} \\ \Delta u_{Nu} \end{bmatrix} \right\} \quad (\text{A.11})$$

As previously said, dual variables only change due to a change in the basis matrix. Therefore, the sensitivity of dual variables, in our case the energy prices, is calculated using (A.9).

Appendix B

Implementations for efficient computation

The aim of this appendix is to describe the mathematical tools employed in the thesis to apply the methodology proposed efficiently.

B.1 INTRODUCTION

This appendix explains the approaches employed in this thesis in order to apply the methodology proposed more efficiently, computationally speaking.

First, the approach used to compute the sensitivities of system variables and dual variables in an efficient way is explained in this appendix. This approach is in line with the analytical developments described in appendix A.

Secondly, the approach employed to implement the methodology more efficiently is described for the two different possible situations: i) how to compute the inverse of the basis matrix, B^{-1} , if the expansion plan affects both the capacity and admittance of transmission assets; and ii) how the number of the required K steps is reduced if the expansion plan affects only the capacity of transmission assets.

B.2 COMPUTE SENSITIVITIES OF SYSTEM VARIABLES AND DUAL VARIABLES EFFICIENTLY

The computation of the sensitivities of system variables and dual variables is required⁹² for the AS process proposed in this thesis. The scheme displaying the application of the method proposed in this thesis is presented in Fig. B.1 (for the sake of convenience, Fig. 3.6 in Chapter 3 is reproduced in this figure). As can be seen in this figure, in each step k of the AS process, where the basis has not changed, the sensitivities have to be computed. As explained in appendix A, a change in the admittance of a transmission asset affected by the deployment of an expansion project directly implies a change in the basis matrix⁹³, ΔB .

⁹² These sensitivities are only required when computing the beneficiaries of the expansion projects (section 3.2 of Chapter 3) and when computing the contribution of expansion projects to other type of benefits (section 3.4 in Chapter 3).

⁹³ A change in the basis matrix does not necessarily involves a change in the basis of the optimal solution of the problem, that is, a change in the set of basic variables.

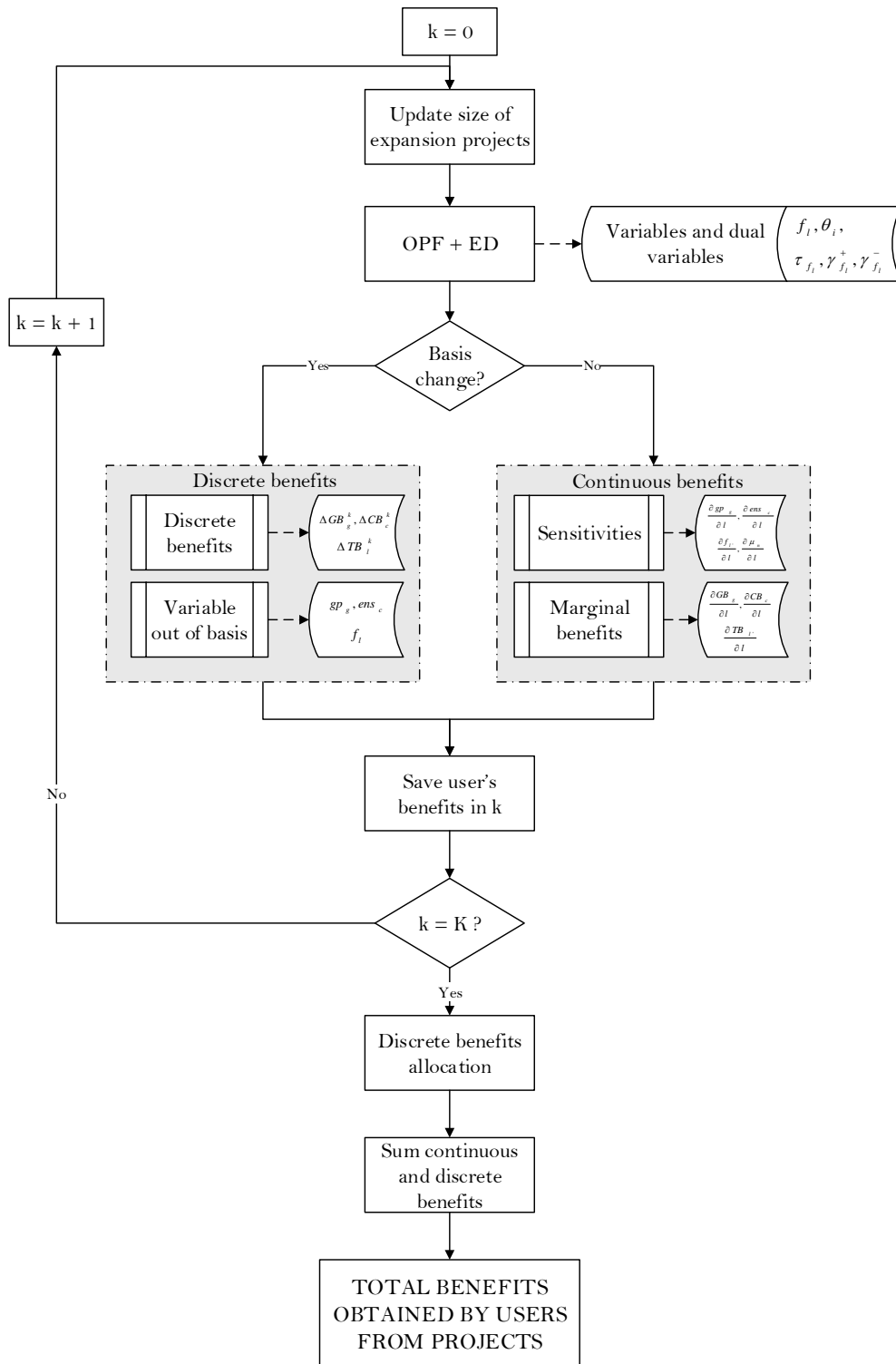

Fig. B.1. Simplified scheme of the application of the method to determine the beneficiaries of individual expansion projects for each time period t considered. All required data to calculate project's beneficiaries is obtained by solving K optimal power flow and economic dispatch problems. This figure corresponds to Fig. 3.6 in Chapter 3.

Appendix A shows that the sensitivity of basic variables and dual variables are computed using (A.8) and (A.9), respectively. For the sake of convenience, both equations are reproduced here.

$$S_{x_B} = -[B + \Delta B]^{-1}[\Delta B \quad \Delta N_l \quad \Delta N_u] \begin{bmatrix} x_B \\ x_{Nl} \\ x_{Nu} \end{bmatrix} \quad (\text{A.8})$$

$$S_{\pi} = ([B + \Delta B]^{-1} - B^{-1})^t c_B \quad (\text{A.9})$$

where matrix ΔB is the change in the basis matrix produced by the deployment of an elemental expansion project that affects the admittance of a transmission asset.

In order to compute the sensitivities of system variables and dual variables with respect to the size of each expansion project, the inverse of matrix $[B + \Delta B]$, $[B + \Delta B]^{-1}$, would have to be compute for each expansion project, which is computationally expensive.

Nonetheless, there is a way to compute this inverse in an efficient manner. Ken Miller in (Miller 1981) provides an efficient way to compute the inverse of a matrix, B , corrected or modified by matrix, ΔB . The computation is relatively efficient because the inverse of the new matrix, $[B + \Delta B]$, does not have to be computed from scratch, but can be computed by modifying matrix B^{-1} (which is already known). As stated by Ken Miller in (Miller 1981), if i) $[B + \Delta B]$ is invertible and ii) the rank of ΔB is one, then the inverse of the new matrix, $[B + \Delta B]^{-1}$, can be computed as in (B.12).

$$[B + \Delta B]^{-1} = B^{-1} - \frac{1}{1+g} \cdot B^{-1} \cdot \Delta B \cdot B^{-1} \quad (\text{B.12})$$

where g is computed as in (B.13).

$$g = \text{trace}(B^{-1} \cdot \Delta B) \quad (\text{B.13})$$

The matrix $[B + \Delta B]$ is invertible. Normally, matrix ΔB would not be of rank one, but in this case, matrix ΔB is of rank one because only the change in the admittance of just one transmission asset $l(ij)$ is considered. Then, $(\vartheta_i - \vartheta_j)y_{l(ij)}$ only affects the coefficients of two variables in the same constraint (row).

B.3 A MORE EFFICIENT IMPLEMENTATION OF THE AS METHOD PROPOSED

The method developed in this thesis proposes the implementation of the AS process in K steps, which simulates the gradual deployment of the expansion plan. This simulation implies that, in every step k , each expansion project is gradually deployed, i.e. the size of each expansion project increases over the K steps. In each of these k steps, the sensitivities of system variables and dual variables have to be computed.

As previously explained, in order to compute these sensitivities efficiently, the matrix B^{-1} is required. In theory, solving the ED and OPF problem in each step k would provide this matrix⁹⁴. However, there could be some cases where this matrix is not available (or that cannot be used) to compute the sensitivities⁹⁵, and computing it in every k step would be computationally demanding. Nevertheless, there are some ways to obtain this matrix efficiently (see section B.3.1). In addition, another approach can be employed in order to largely reduce the number of steps required in the AS process (see section B.3.2).

Please note that the gradual deployment of the expansion plan –and thus, of expansion projects– may affect the capacity and/or the admittance of transmission assets depending on the type of project considered. In the following sections, two different methods are proposed to apply the AS process in a more efficient manner, depending on the situation:

- i. The expansion plan, or group of projects, affects both the capacity and admittance of transmission assets.
- ii. The expansion plan, or group of projects, only affects the capacity of transmission assets.

B.3.1 The expansion plan affects both the capacity and admittance of transmission assets

In case the admittance of the transmissions assets is affected by expansion projects (and thus, it affects the system operation), the basis matrix B may change from one iteration, k , to another, $k+1$, without a change in the basis (the set of basic variables remain the same). As stated, computing in every step k the inverse B_k^{-1} would be very expensive. However, a similar idea to the one applied for the computation of the sensitivities can be employed here. This way, the matrix B_{k+1}^{-1} in step $k+1$ can be computed using the matrix B_k^{-1} previously computed in step k , if the basis has not changed.

The basis matrix in step k and $k+1$ are B_k and B_{k+1} , respectively. Matrix B_{k+1} can be expressed as in (B.14).

$$B_{k+1} = B_k + \Delta B_{k \rightarrow k+1} = B_k + \Delta B_k \quad (\text{B.14})$$

where $\Delta B_{k \rightarrow k+1}$ represents the changes in the basis matrix produced by the deployment of the elemental expansion projects between steps k and $k+1$. In order to simplify the notation, matrix B_k and matrix $\Delta B_{k \rightarrow k+1}$ are represented by B and ΔB , respectively.

⁹⁴ According to optimization theory, this matrix is computed in order to obtain the optimal solution of the problem.

⁹⁵ Some solvers may not provide this matrix in order to be employed by the user.

The objective is to find the inverse of $[B + \Delta B]$ in order to apply the previously explained approach. Hence, the idea is to decompose matrix ΔB into a sum of matrices of rank one and iteratively apply the approach employed to compute the sensitivity of system variables and dual variables (B.12)-(B.13). If it is known that ΔB has a positive rank r , then matrix ΔB may be rewritten as in (B.15).

$$\Delta B = \Delta B_1 + \Delta B_2 + \Delta B_3 + \dots + \Delta B_r \quad (\text{B.15})$$

where each ΔB_i , $1 \leq i \leq r$, has rank one. Thus, matrix $[B + \Delta B]$ may be expressed as in (B.16).

$$B + \Delta B = B + \Delta B_1 + \Delta B_2 + \Delta B_3 + \dots + \Delta B_r \quad (\text{B.16})$$

Please note that each ΔB_i represents the change in the basis matrix produced by the deployment of each elemental expansion project. If each of the partial sums $C_{n+1} = B + \Delta B_1 + \Delta B_2 + \Delta B_3 + \dots + \Delta B_n$ is nonsingular for $n = 1, \dots, r$, the inverse of each partial sum can be computed using (B.17).

$$C_{n+1}^{-1} = C_n^{-1} - \frac{1}{1+g_n} \cdot C_n^{-1} \cdot \Delta B_n \cdot C_n^{-1} \quad n = 1, \dots, r \quad (\text{B.17})$$

where g_n is calculated as in (B.18).

$$g_n = \text{trace}(C_n^{-1} \cdot \Delta B_n) \quad (\text{B.18})$$

In particular, the inverse of matrix $[B + \Delta B]$ may be computed as in (B.19).

$$[B + \Delta B]^{-1} = C_r^{-1} - g_r \cdot C_r^{-1} \cdot \Delta B_r \cdot C_r^{-1} \quad (\text{B.19})$$

The reader should note that (B.12) is the particularization of (B.19) for $r = 1$.

B.3.2 The expansion plan only affects the capacity of transmission assets

In case only the capacity of the transmissions assets is affected by expansion projects (and thus, it affects the system operation), the basis matrix B does not change from one iteration, k , to another, $k+1$, except if there is a change in the basis of the problem (the set of basic variables changes). Therefore, the inverse of the basis matrix, B^{-1} , would remain constant from one iteration to another as long as the basis of the problem does not change. In this situation, the inverse of the basis matrix, B^{-1} , does not have to be computed in every step k of the process, only in the steps where the basis is going to change.

In fact, instead of solving the ED and OPF problems through the K steps of the AS process, the ED and OPF problems can be solved only in the steps where the basis would change. This is so because, in this situation, the marginal benefits of expansion projects

will remain constant over the whole size of each step (i.e. until there is a shift in the basis). Thus, instead of using K steps of equal size, the size of each step k may be different depending on the “location” of the basis shifts. This implies that, not only matrix B^{-1} does not have to be computed in every k step of the AS algorithm, but also that the number of steps can be heavily reduced.

Illustrative example

Fig. B.2 shows the evolution of the marginal benefits provided by each expansion project of the illustrative example employed through this thesis. As can be seen, marginal benefits of projects AB and AC only change when there is a shift in the basis of the problem. Therefore, the methodology proposed can be applied only in three steps: the initial step $k = 0$ and the steps where the basis changes (*1 and *2 in the Fig. B.2).

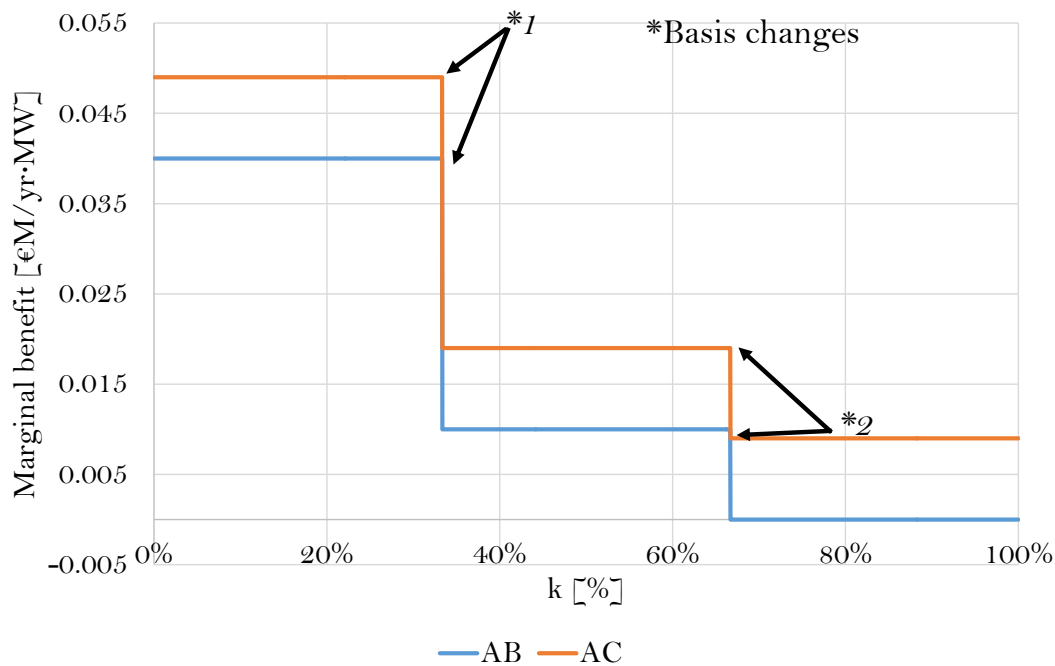

Fig. B.2. Evolution of the marginal benefits provided by expansion projects through all the steps k of application of the AS approach (gradual deployment of the plan simulated in AS). Changes in the basis of the problem are indicated with an *. The original figure corresponds to Chapter 3 (Fig. 3.5), and belongs to the illustrative example employed through this thesis.

Using sensitivity analysis⁹⁶, we are able to know, for each constraint, how much the RHS coefficients can be changed without causing a shift in the basis of the optimal solution. Therefore, the length of each step is calculated as the minimum change in the RHS of the constraints setting the upper and lower bound of power flows in each asset, which is affected by expansion projects, that changes the basis of the problem. Remember that the K steps taken in the implementation of the AS algorithm simulate the gradual deployment of the expansion plan, and thus, the gradual deployment of the projects within the plan. This implies that the size of expansion projects increases in a homothetic way during the K steps of the process. Hence, the minimum change in the RHS of the constraints has also to respect these homothetic increases.

⁹⁶ The solvers available usually provide this sensitivity analysis.

REFERENCES

- 3E et al., 2011. *Offshore Electricity Grid Infrastructure in Europe*, Available at: http://www.offshoregrid.eu/images/FinalReport/offshoregrid_fullfinalreport.pdf.
- ACER, 2013. *Recommendation No 07/2013 regarding the cross-border cost allocation requests submitted in the framework of the first union list of electricity and gas projects of common interest, 25 September.*
- Alonso-Mejide, J.M. & Carreras, F., 2011. The proportional coalitional Shapley value. *Expert Systems with Applications*, 38, pp.6967–6979.
- Aumann, R.J. & Shapley, L.S., 1974. *Values of Non-Atomic Games*, Princeton Univ. Press.
- Bakirtzis, A.G., 2001. Aumann-Shapley Transmission Congestion Pricing. *IEEE Power Engineering Review*, 2001(March), pp.67–69.
- Banez-Chicharro, F. et al., 2017a. Beneficiaries of transmission expansion projects of an expansion plan: An Aumann-Shapley approach. *Applied Energy*, 195, pp.382–401. Available at: <http://linkinghub.elsevier.com/retrieve/pii/S0306261917302891>.
- Banez-Chicharro, F. et al., 2017b. Estimating the benefits of transmission expansion projects: An Aumann-Shapley approach. *Energy*, 118, pp.1044–1054. Available at: <http://linkinghub.elsevier.com/retrieve/pii/S036054421631581X>.
- Battaglini, A. et al., 2012. Perception of barriers for expansion of electricity grids in the European Union. *Energy Policy*, 47, pp.254–259. Available at: <http://linkinghub.elsevier.com/retrieve/pii/S0301421512003709> [Accessed December 16, 2014].
- Billera, L.J., Heath, D.C. & Raanan, J., 1978. Internal Telephone Billing Rates—A Novel Application of Non-Atomic Game Theory. *Operations Research*, 26(6), pp.956–965.
- Bogetoft, P., Hougaard, J.L. & Smilgins, A., 2016. Applied cost allocation: The DEA-Aumann-Shapley approach. *European Journal of Operational Research*, 254(2), pp.667–678.
- Bresemi, P. et al., 2009. The benefits of transmission expansions in the competitive electricity markets☆. *Energy*, 34(3), pp.274–280. Available at: <http://linkinghub.elsevier.com/retrieve/pii/S0360544208002478> [Accessed February 14, 2013].
- Buijs, P. et al., 2011. Transmission investment problems in Europe: Going beyond standard solutions. *Energy Policy*, 39(3), pp.1794–1801. Available at: <http://linkinghub.elsevier.com/retrieve/pii/S030142151100022X> [Accessed March 5, 2013].
- CAISO, 2004. *Transmission Economic Assessment Methodology (TEAM)*.
- Chamorro, J.M. et al., 2012. Market-based valuation of transmission network expansion. A heuristic application in GB. *Energy*, 44(1), pp.302–320. Available at: <http://linkinghub.elsevier.com/retrieve/pii/S0360544212004793> [Accessed March 3, 2013].

- Chang, J.W. & Pfeifenberger, J., 2016. Future for Competitive Transmission: What Have We Learned, and Where Do We Go from Here? Available at: <http://books.google.nl/books?hl=en&lr=&id=9IXYZgzWVjYC&oi=fnd&pg=PA303&dq=What+Have+We+Learned,+and+Where+Do+We+Go+from+Here%3F&ots=iNQrjtree3&sig=639ezGKdDcCq8uZ3H8y4rLeUMNA#v=onepage&q=What+Have+We+Learned%2C+and+Where+Do+We+Go+from+Here%3F&f=false>.
- Chang, J.W., Pfeifenberger, J.P. & Hagerty, J.M., 2013. *The Benefits of Electric Transmission: Identifying and Analyzing the Value of Investments*,
- Chang, K., Zhang, C. & Chang, H., 2016. Emissions reduction allocation and economic welfare estimation through interregional emissions trading in China: Evidence from efficiency and equity. *Energy*, 113, pp.1125–1135. Available at: <http://dx.doi.org/10.1016/j.energy.2016.07.113>.
- Ciupuliga, a. R. & Cuppen, E., 2013. The role of dialogue in fostering acceptance of transmission lines: the case of a France–Spain interconnection project. *Energy Policy*, 60, pp.224–233. Available at: <http://linkinghub.elsevier.com/retrieve/pii/S0301421513003601> [Accessed December 16, 2014].
- Contreras, J. et al., 2009. An incentive-based mechanism for transmission asset investment. *Decision Support Systems*, 47(1), pp.22–31. Available at: <http://linkinghub.elsevier.com/retrieve/pii/S0167923609000049> [Accessed July 8, 2013].
- Coxe, R. & Meeus, L., 2010. Survey of non-traditional transmission development. *IEEE PES General Meeting*, 1(978), pp.1–6. Available at: <http://ieeexplore.ieee.org/lpdocs/epic03/wrapper.htm?arnumber=5589749>.
- Curien, N., 2003. *Transport Pricing of Electricity Networks* F. Lévêque, ed., Boston, MA: Springer US. Available at: <http://link.springer.com/10.1007/978-1-4757-3756-1> [Accessed June 26, 2014].
- Dabbagh, S.R. & Sheikh-El-Eslami, M.K., 2015. Risk-based profit allocation to DERs integrated with a virtual power plant using cooperative Game theory. *Electric Power Systems Research*, 121, pp.368–378. Available at: <http://dx.doi.org/10.1016/j.epsr.2014.11.025>.
- Desertec Foundation, 2009. *Red paper. An Overview of the Desertec Concept*,
- Dietrich, K., Olmos, L. & Pérez-Arriaga, I.J., 2008. An Application of the Aumann-Shapley Approach to the Calculation of Inter TSO Compensations in the UCTE System. In *5th International Conference on the European Energy Market - EEM'08*. Lisbon, Portugal.
- Diyun Huang et al., 2016. Mind the gap: Challenges and policy options for cross-border transmission network investments. In *2016 13th International Conference on the European Energy Market (EEM)*. IEEE, pp. 1–6. Available at: <http://ieeexplore.ieee.org/document/7521211/>.
- ENTSO-E, 2013. *ENTSO-E Guideline for Cost Benefit Analysis of Grid Development Projects*, Brussels. Available at: https://www.entsoe.eu/fileadmin/user_upload/_library/events/Workshops/CBA/1

- 31114_ENTSO-E_CBA_Methodology.pdf.
- ENTSO-E, 2016. *Ten-Year Network Development Plan 2016. Executive Report*, Brussels. Available at: <http://tyndp.entsoe.eu/exec-report/>.
- ENTSO-E, 2014. *Ten Year Network Development Plan 2014*,
- European Climate Foundation, 2010. *Roadmap 2050. Practical guide to a prosperous, low carbon Europe*, Available at: http://www.europeanclimate.org/index.php?option=com_content&task=view&id=72&Itemid=79.
- European Commission, 2011a. *COMMISSION STAFF WORKING PAPER Energy infrastructure investment needs and financing requirements*, Brussels. Available at: http://register.consilium.europa.eu/doc/srv?l=EN&f=ST_11056_2011_INIT.
- European Commission, 2011b. *Energy 2020. A strategy for competitive, sustainable and secure energy*,
- European Union, 2013. *Regulation (EU) No 347/2013 of the European Parliament and of the Council of 17 April 2013 on guidelines for trans-European energy infrastructure and repealing Decision No 1364/2006/EC and amending Regulations (EC) No 713/2009, (EC) No 714/2009 and (EC) N*, Available at: <http://eur-lex.europa.eu/legal-content/EN/TXT/PDF/?uri=CELEX:32013R0347&from=en>.
- Faria, E. et al., 2009. Allocation of firm-energy rights among hydro plants: An Aumann-Shapley approach. *IEEE Transactions on Power Systems*, 24(2), pp.541–551.
- Federal Energy Regulatory Commission (FERC), Final Rule on Transmission Planning and Cost Allocation by Transmission Owning and Operation Public Utilities. Briefing on Order No. 1000. , (1000).
- Federal Energy Regulatory Commission (FERC), 2012. *Transmission Planning and Cost Allocation by Transmission Owning and Operating Public Utilities*, Available at: <http://www.ferc.gov/industries/electric/indus-act/trans-plan.asp>.
- von der Fehr, N.-H.M. et al., 2013. *Cost Benefit Analysis in the Context of the Energy Infrastructure Package*,
- Fitiwi, D.Z. et al., 2015. A new approach of clustering operational states for power network expansion planning problems dealing with RES (renewable energy source) generation operational variability and uncertainty. *Energy*, pp.1–17. Available at: <http://linkinghub.elsevier.com/retrieve/pii/S0360544215008348>.
- Florio, M. et al., 2008. *Guide to Cost-Benefit Analysis of Investment Projects*,
- Freire, L. et al., 2015. A Hybrid MILP and Benders Decomposition Approach to Find the Nucleolus Quota Allocation for a Renewable Energy Portfolio. *IEEE Transactions on Power Systems*, 30(6), pp.3265–3275. Available at: <http://ieeexplore.ieee.org/document/6996036/>.
- Frias, P., Gomez, T. & Soler, D., 2008. A Reactive Power Capacity Market Using Annual Auctions. *IEEE Transactions on Power Systems*, 23(3), pp.1458–1468. Available at: <http://ieeexplore.ieee.org/document/4526213/>.
- Fürsch, M. et al., 2013. The role of grid extensions in a cost-efficient transformation of

- the European electricity system until 2050. *Applied Energy*, 104, pp.642–652. Available at: <http://linkinghub.elsevier.com/retrieve/pii/S0306261912008537> [Accessed December 13, 2014].
- Giordano, V. et al., 2012. *Guidelines for conducting a cost-benefit analysis of Smart Grid projects*, Available at: <http://ses.jrc.ec.europa.eu/publications/reports/guidelines-conducting-cost-benefit-analysis-smart-grid-projects>.
- Godron, P. et al., 2014. *DESERT POWER : GETTING CONNECTED Starting the debate for the grid infrastructure for a sustainable power supply in EUMENA. Executive Summary*,
- Hadush, S.Y., Buijs, P. & Belmans, R., 2011. Offshore Wind Power Generation & Transmission Tariff Design Options. *11th Young Energy Economists & Engineers Seminar - YEEES*, pp.1–36.
- Hasan, K.N. et al., 2014. Benefit-based expansion cost allocation for large scale remote renewable power integration into the Australian grid. *Applied Energy*, 113, pp.836–847. Available at: <http://linkinghub.elsevier.com/retrieve/pii/S0306261913006740> [Accessed September 19, 2013].
- Henriot, A., 2013. Financing investment in the European electricity transmission network: Consequences on long-term sustainability of the TSOs financial structure. *Energy Policy*, 62, pp.821–829. Available at: <http://linkinghub.elsevier.com/retrieve/pii/S030142151300654X> [Accessed December 4, 2014].
- Hu Zhaoyang, Z. et al., 2006. Allocation of unit start-up costs using cooperative game theory. *IEEE Transactions on Power Systems*, 21(2), pp.653–662.
- Junqueira, M. et al., 2007. An Aumann-Shapley Approach to Allocate Transmission Service Cost Among Network Users in Electricity Markets. *IEEE Transactions on Power Systems*, 22(4), pp.1532–1546. Available at: <http://ieeexplore.ieee.org/lpdocs/epic03/wrapper.htm?arnumber=4349092> [Accessed September 20, 2013].
- Kassakian, J.G. et al., 2011. *The Future of the Electric Grid*, Cambridge, Massachusetts: MIT. Available at: <http://web.mit.edu/mitei/research/studies/the-electric-grid-2011.shtml>.
- Krishnan, V. et al., 2013. Nation-wide transmission overlay design and benefits assessment for the U.S. *Energy Policy*, 56(2013), pp.221–232. Available at: <http://linkinghub.elsevier.com/retrieve/pii/S0301421512011044> [Accessed December 16, 2014].
- Latorre, G. et al., 2003. Classification of publications and models on transmission expansion planning. *IEEE Transactions on Power Systems*, 18(2), pp.938–946. Available at: <http://ieeexplore.ieee.org/lpdocs/epic03/wrapper.htm?arnumber=1198335> [Accessed June 26, 2014].
- Liberopoulos, G. & Andrianesis, P., 2014. Analysis and Comparison of Pricing Schemes in Markets with Non- Convex Costs : Lessons from a Duopoly. , (May).

- Lin, X.J. et al., 2006. Reactive power service cost allocation using Aumann-Shapley method. *IEE Proceedings - Generation, Transmission and Distribution*, 153(5), p.540. Available at: http://digital-library.theiet.org/content/journals/10.1049/ip-gtd_20040098.
- Lin, X.J., Yu, C.W. & Chung, C.Y., 2005. Pricing of reactive support ancillary services. *IEE Proceedings - Generation, Transmission and Distribution*, 152(5), p.616. Available at: http://digital-library.theiet.org/content/journals/10.1049/ip-gtd_20040098.
- Lumbreras, S., Ramos, A., Banez-Chicharro, F., et al., 2017. Large-scale Transmission Expansion Planning: from zonal results to a nodal expansion plan. *Under review in IET Generation, Transmission & Distribution*.
- Lumbreras, S. et al., 2016. Real options valuation applied to transmission expansion planning. *Quantitative Finance*, 16(2), pp.231–246. Available at: <http://www.tandfonline.com/doi/full/10.1080/14697688.2015.1114362>.
- Lumbreras, S., Banez-Chicharro, F. & Pache, C., 2015. *e-HIGHWAY2050 D8.3a: Enhanced methodology to define optimal grid architectures for 2050*,
- Lumbreras, S. & Ramos, A., 2016. The new challenges to transmission expansion planning. Survey of recent practice and literature review. *Electric Power Systems Research*, 134, pp.19–29. Available at: <http://dx.doi.org/10.1016/j.epsr.2015.10.013>.
- Lumbreras, S., Ramos, A. & Banez-Chicharro, F., 2017. Optimal Transmission Network Expansion Planning in Real-Sized Power Systems with High Renewable Penetration. *Under review in Electric Power Systems Research*.
- Lumbreras, S., Ramos, a. & Sánchez, P., 2014. Automatic selection of candidate investments for Transmission Expansion Planning. *International Journal of Electrical Power & Energy Systems*, 59, pp.130–140. Available at: <http://linkinghub.elsevier.com/retrieve/pii/S0142061514000799> [Accessed October 10, 2014].
- Meeus, L. & Keyaerts, N., 2015. First series of cross-border cost allocation decisions for projects of common interest: Main lessons learned.
- Meeus, L. & Keyaerts, N., 2014. *The role of the EU and ACER to ensure and adequate regulatory framework for projects of common interest*, Available at: <http://bookshop.europa.eu/es/the-role-of-the-eu-and-acer-to-ensure-an-adequate-regulatory-framework-for-projects-of-common-interest-pbQMAI14005/>.
- Mezosi, A. & Szabo, L., 2014. Model based evaluation of electricity network investments with regional importance. In *11th International Conference on the European Energy Market (EEM14)*. pp. 1–6. Available at: <http://ieeexplore.ieee.org/lpdocs/epic03/wrapper.htm?arnumber=6861254>.
- Migliavacca, G. et al., 2011. The REALISEGRID cost-benefit methodology to rank pan-European infrastructure investments. *2011 IEEE PES Trondheim PowerTech: The Power of Technology for a Sustainable Society, POWERTECH 2011*, 219123, pp.1–7.
- Miller, K.S., 1981. On the Inverse of the Sum of Matrices. *Mathematics Magazine*, 54(2), p.67. Available at: <http://epubs.siam.org/doi/abs/10.1137/1023004>.
- Molina, Y.P., Prada, R.B. & Saavedra, O.R., 2010. Complex losses allocation to generators

- and loads based on circuit theory and aumann-shapley method. *IEEE Transactions on Power Systems*, 25(4), pp.1928–1936.
- Molina, Y.P., Saavedra, O.R. & Amaris, H., 2013. Transmission Network Cost Allocation Based on Circuit Theory and the Aumann-Shapley Method. *IEEE Transactions on Power Systems*, pp.1–10. Available at: <http://ieeexplore.ieee.org/lpdocs/epic03/wrapper.htm?arnumber=6585780> [Accessed September 20, 2013].
- Morais, M.S. & Marangon Lima, J.W., 2007. Combined natural gas and electricity network pricing. *Electric Power Systems Research*, 77(5–6), pp.712–719.
- Neuhoff, K., Boyd, R. & Glachant, J.-M., 2012. *European Electricity Infrastructure: Planning, Regulation, and Financing. CPI Workshop Report*, Available at: <http://climatepolicyinitiative.org/wp-content/uploads/2012/01/EU-Grid-Workshop-Summary-2012.01.25.pdf>.
- Nguyen, P.H., Kling, W.L. & Ribeiro, P.F., 2013. A game theory strategy to integrate distributed agent-based functions in smart grids. *IEEE Transactions on Smart Grid*, 4(1), pp.568–576.
- Nooij, M. de, 2011. Social cost-benefit analysis of electricity interconnector investment: A critical appraisal. *Energy Policy*, 39(6), pp.3096–3105. Available at: <http://linkinghub.elsevier.com/retrieve/pii/S0301421511001418> [Accessed March 5, 2013].
- Olmos, L., Rivier, M. & Cabezudo, D., 2013. An Analysis of the Marginal Value of Electricity Transmission Lines in the Dispatch: Possible Applications. *IEEE Transactions on Power Systems*, 28(3), pp.2737–2748. Available at: <http://ieeexplore.ieee.org/lpdocs/epic03/wrapper.htm?arnumber=6507351> [Accessed September 21, 2013].
- Pérez-Arriaga, I.J. ed., 2013. *Regulation of the Power Sector*, London: Springer London. Available at: <http://link.springer.com/10.1007/978-1-4471-5034-3> [Accessed June 1, 2014].
- Pierru, A., 2007. Allocating the CO₂ emissions of an oil refinery with Aumann–Shapley prices. *Energy Economics*, 29(3), pp.563–577. Available at: <http://linkinghub.elsevier.com/retrieve/pii/S0140988306000156>.
- Ploussard, Q., Olmos, L. & Ramos, A., 2016. An operational state aggregation technique for transmission expansion planning based on line benefits. *IEEE Transactions on Power Systems*, (c), pp.1–1. Available at: <http://ieeexplore.ieee.org/document/7582509/>.
- Purvins, A. et al., 2011. Challenges and options for a large wind power uptake by the European electricity system. *Applied Energy*, 88(5), pp.1461–1469. Available at: <http://dx.doi.org/10.1016/j.apenergy.2010.12.017>.
- Rivier, M., Pérez-Arriaga, I.J. & Olmos, L., 2013. Electricity Transmission. In I. J. Pérez-Arriaga, ed. *Regulation of the Power Sector*. Springer, pp. 251–340. Available at: http://link.springer.com/10.1007/978-1-4471-5034-3_6.
- Roth, A.E., 1988. *The Shapley Value. Essays in honor of Lloyd S. Shapley* A. E. Roth, ed.,

- Cambridge University Press. Available at: <http://ebooks.cambridge.org/ref/id/CBO9780511528446>.
- Roustaei, M., Sheikh-El-Eslami, M.K. & Seifi, H., 2014. Transmission cost allocation based on the users' benefits. *International Journal of Electrical Power & Energy Systems*, 61, pp.547–552. Available at: <http://linkinghub.elsevier.com/retrieve/pii/S0142061514001641> [Accessed May 29, 2014].
- Samet, D., Tauman, Y. & Zang, I., 1984. An Application of the Aumann-Shapley Prices for Cost Allocation in Transportation Problems. *Mathematics of Operations Research*, 9(1), pp.25–42.
- Sanchis, G. et al., 2015. The Corridors of Power: A Pan-European “Electricity Highway” System for 2050. *IEEE Power and Energy Magazine*, 13(february), pp.38–51. Available at: <http://mt.m2day.org/nuc2007/>.
- Saphores, J.-D., Gravel, E. & Bernard, J.-T., 2004. Regulation and Investment under Uncertainty: An Application to Power Grid Interconnection. *Journal of Regulatory Economics*, 25(2), pp.169–186. Available at: <http://link.springer.com/10.1023/B:REGE.0000012288.66438.f5>.
- Stamtsis, G.C. & Erlich, I., 2004. Use of cooperative game theory in power system fixed-cost allocation. *IEE Proceedings - Generation, Transmission and Distribution*, 151(3), p.401. Available at: http://digital-library.theiet.org/content/journals/10.1049/ip-gtd_20040156 [Accessed September 20, 2013].
- Tan, X. & Lie, T.T., 2002. Application of the Shapley Value on transmission cost allocation in the competitive power market environment. *Iee Proceedings-Generation Transmission and Distribution*, 149(1), pp.15–20. Available at: isi:000174382200003.
- Tsukamoto, Y. & Iyoda, I., 1996. Allocation of fixed transmission cost to wheeling transactions by cooperative game theory. *IEEE Transactions on Power Systems*, 11(2), pp.620–629.
- Winter, E., 2002. The Shapley Value. In R. J. Aumann & S. Hart, eds. *Handbook of Game Theory*. Elsevier.
- Wu, F., Zheng, F. & Wen, F., 2006. Transmission investment and expansion planning in a restructured electricity market. *Energy*, 31(6–7), pp.954–966. Available at: <http://linkinghub.elsevier.com/retrieve/pii/S0360544205000538> [Accessed March 5, 2013].
- Wu, Z.Q. et al., 2004. Continuous integration congestion cost allocation based on sensitivity. *IEE Proceedings - Generation, Transmission and Distribution*, 151(4), p.421. Available at: http://digital-library.theiet.org/content/journals/10.1049/ip-gtd_20040098.
- Yang, Y. & Xiao, H., 2012. Allocation of congestion cost based on Aumann-Shapley value in bilateral transaction framework. *Asia-Pacific Power and Energy Engineering Conference, APPEEC*.
- Young, H.P., 1994. Cost allocation. In R. J. Aumann & S. Hart, eds. *Handbook of Game Theory*. New York: Elsevier.

- Zickfeld, F. et al., 2013. *Desert Power: Getting Started*, Munich, Germany.
- Zima-Bočkarjova, M. et al., 2010. Sharing of profit from coordinated operation planning and bidding of hydro and wind power. *IEEE Transactions on Power Systems*, 25(3), pp.1663–1673.
- Zolezzi, J.M. & Rudnick, H., 2002. Transmission cost allocation by cooperative games and coalition formation. *IEEE Transactions on Power Systems*, 17(4), pp.1008–1015.

