



COMILLAS
UNIVERSIDAD PONTIFICIA

ICAI

GRADO EN INGENIERÍA EN TECNOLOGÍAS INDUSTRIALES
GITI

TRABAJO FIN DE GRADO

**PARAMETRIC STUDY OF ELECTRIC
MOTORS AND GENERATORS FOR
HYBRID PROPULSION SYSTEMS IN THE
AVIATION INDUSTRY**

Author: Laura Ruiz Lozano

Director: Juan Norverto Moriño

Madrid

Septiembre de 2019

AUTORIZACIÓN PARA LA DIGITALIZACIÓN, DEPÓSITO Y DIVULGACIÓN EN RED DE PROYECTOS FIN DE GRADO, FIN DE MÁSTER, TESIS O MEMORIAS DE BACHILLERATO

1º. Declaración de la autoría y acreditación de la misma.

El autor D^a. Laura Ruiz Lozano DECLARA ser el titular de los derechos de propiedad intelectual de la obra: PARAMETRIC STUDY OF ELECTRIC MOTORS AND GENERATORS FOR HYBRID PROPULSION SYSTEMS IN THE AVIATION INDUSTRY, que ésta es una obra original, y que ostenta la condición de autor en el sentido que otorga la Ley de Propiedad Intelectual.

2º. Objeto y fines de la cesión.

Con el fin de dar la máxima difusión a la obra citada a través del Repositorio institucional de la Universidad, el autor **CEDE** a la Universidad Pontificia Comillas, de forma gratuita y no exclusiva, por el máximo plazo legal y con ámbito universal, los derechos de digitalización, de archivo, de reproducción, de distribución y de comunicación pública, incluido el derecho de puesta a disposición electrónica, tal y como se describen en la Ley de Propiedad Intelectual. El derecho de transformación se cede a los únicos efectos de lo dispuesto en la letra a) del apartado siguiente.

3º. Condiciones de la cesión y acceso

Sin perjuicio de la titularidad de la obra, que sigue correspondiendo a su autor, la cesión de derechos contemplada en esta licencia habilita para:

- a) Transformarla con el fin de adaptarla a cualquier tecnología que permita incorporarla a internet y hacerla accesible; incorporar metadatos para realizar el registro de la obra e incorporar “marcas de agua” o cualquier otro sistema de seguridad o de protección.
- b) Reproducirla en un soporte digital para su incorporación a una base de datos electrónica, incluyendo el derecho de reproducir y almacenar la obra en servidores, a los efectos de garantizar su seguridad, conservación y preservar el formato.
- c) Comunicarla, por defecto, a través de un archivo institucional abierto, accesible de modo libre y gratuito a través de internet.
- d) Cualquier otra forma de acceso (restringido, embargado, cerrado) deberá solicitarse expresamente y obedecer a causas justificadas.
- e) Asignar por defecto a estos trabajos una licencia Creative Commons.
- f) Asignar por defecto a estos trabajos un HANDLE (URL *persistente*).

4º. Derechos del autor.

El autor, en tanto que titular de una obra tiene derecho a:

- a) Que la Universidad identifique claramente su nombre como autor de la misma
- b) Comunicar y dar publicidad a la obra en la versión que ceda y en otras posteriores a través de cualquier medio.
- c) Solicitar la retirada de la obra del repositorio por causa justificada.
- d) Recibir notificación fehaciente de cualquier reclamación que puedan formular terceras personas en relación con la obra y, en particular, de reclamaciones relativas a los derechos de propiedad intelectual sobre ella.

5º. Deberes del autor.

El autor se compromete a:

- a) Garantizar que el compromiso que adquiere mediante el presente escrito no infringe ningún derecho de terceros, ya sean de propiedad industrial, intelectual o cualquier otro.
- b) Garantizar que el contenido de las obras no atenta contra los derechos al honor, a la intimidad y a la imagen de terceros.
- c) Asumir toda reclamación o responsabilidad, incluyendo las indemnizaciones por daños, que

pudieran ejercitarse contra la Universidad por terceros que vieran infringidos sus derechos e intereses a causa de la cesión.

- d) Asumir la responsabilidad en el caso de que las instituciones fueran condenadas por infracción de derechos derivada de las obras objeto de la cesión.

6º. Fines y funcionamiento del Repositorio Institucional.

La obra se pondrá a disposición de los usuarios para que hagan de ella un uso justo y respetuoso con los derechos del autor, según lo permitido por la legislación aplicable, y con fines de estudio, investigación, o cualquier otro fin lícito. Con dicha finalidad, la Universidad asume los siguientes deberes y se reserva las siguientes facultades:

- La Universidad informará a los usuarios del archivo sobre los usos permitidos, y no garantiza ni asume responsabilidad alguna por otras formas en que los usuarios hagan un uso posterior de las obras no conforme con la legislación vigente. El uso posterior, más allá de la copia privada, requerirá que se cite la fuente y se reconozca la autoría, que no se obtenga beneficio comercial, y que no se realicen obras derivadas.
- La Universidad no revisará el contenido de las obras, que en todo caso permanecerá bajo la responsabilidad exclusiva del autor y no estará obligada a ejercitar acciones legales en nombre del autor en el supuesto de infracciones a derechos de propiedad intelectual derivados del depósito y archivo de las obras. El autor renuncia a cualquier reclamación frente a la Universidad por las formas no ajustadas a la legislación vigente en que los usuarios hagan uso de las obras.
- La Universidad adoptará las medidas necesarias para la preservación de la obra en un futuro.
- La Universidad se reserva la facultad de retirar la obra, previa notificación al autor, en supuestos suficientemente justificados, o en caso de reclamaciones de terceros.

Madrid, a 30 de agosto de 2019

ACEPTA

Fdo.....

Declaro, bajo mi responsabilidad, que el Proyecto presentado con el título
PARAMETRIC STUDY OF ELECTRIC MOTORS AND GENERATORS FOR HYBRID
PROPULSION SYSTEMS

en la ETS de Ingeniería - ICAI de la Universidad Pontificia Comillas en el
curso académico 2018-2019 es de mi autoría, original e inédito y
no ha sido presentado con anterioridad a otros efectos. El Proyecto no es plagio de otro, ni total ni
parcialmente y la información que ha sido tomada
de otros documentos está debidamente referenciada.

Fdo.: LAURA RUIZ LOZANO

Fecha: 30 de agosto de 2019



Autorizada la entrega del proyecto

EL DIRECTOR DEL PROYECTO



Fdo.: JUAN NORVERTO MORIÑIGO

Fecha: 30 de agosto de 2019

* POR AUSENCIA TUTOR ORIGINAL



COMILLAS
UNIVERSIDAD PONTIFICIA

ICAI

GRADO EN INGENIERÍA EN TECNOLOGÍAS INDUSTRIALES

GITI

TRABAJO FIN DE GRADO

**PARAMETRIC STUDY OF ELECTRIC
MOTORS AND GENERATORS FOR
HYBRID PROPULSION SYSTEMS IN THE
AVIATION INDUSTRY**

Author: Laura Ruiz Lozano

Director: Juan Norverto Moriño

Madrid

Septiembre de 2019

PARAMETRIC STUDY OF ELECTRIC MOTORS AND GENERATORS FOR HYBRID PROPULSION SYSTEMS IN THE AVIATION INDUSTRY

Autor: Ruiz Lozano, Laura.

Director: Norverto Moriñigo, Juan.

Entidad Colaboradora: ICAI – Universidad Pontificia Comillas.

RESÚMEN

El enfoque del siguiente trabajo es hacer un estudio preliminar de las nuevas tecnologías que se quieren implementar en la aviación actual. Más en concreto, éste estudio quiere llegar a conocer más en profundidad los nuevos métodos de generación de energía dentro de las aeronaves. La electrificación de los sistemas de propulsión.

La aviación ha estado sometida a todo tipo de cambios y avances a lo largo de la historia, pero en los últimos años el gran desafío ha sido la reducción de emisiones de gases contaminantes. Al centrarse en los futuros objetivos medioambientales de la aviación comercial, existe un compromiso entre muchos aspectos que deben tenerse en cuenta: viabilidad, reducción del consumo de combustible, seguridad y fiabilidad y reducción del ruido.

Todo ello, con la ayuda de las nuevas tecnologías, nos llevan a la utilización de máquinas eléctricas de alta velocidad para sustituir los actuales motores de combustión. De los resultados obtenidos, la mejor opción resulta ser la máquina síncrona de imán permanente, ya que tiene mayor eficiencia, densidad de potencia y las menores pérdidas mecánicas, lo que la convierte en una de las más adecuadas para trabajar en un rango más amplio de altas velocidades.

Una de las claves para lanzar este tipo de proyectos son las ventajas que tienen para los consumidores. Los nuevos aviones eléctricos o híbridos ofrecen billetes más baratos, menos ruido y una tasa de ascenso más alta. Con los motores eléctricos, estos aviones pueden mantener el rendimiento a mayores altitudes donde la resistencia del aire es menor, a diferencia de los motores de combustión que operan de manera menos eficiente a estas altitudes.

Por esta razón, muchas empresas de aviación y start-ups comenzaron a desarrollar nuevas tecnologías para cumplir con los objetivos. Uno de los mayores inversores en este campo es Airbus. Esta tecnología comienza en 2010, evolucionando con modelos de aeronaves como el *Colomban Cri-Cri*, el *E-Fan* y el *Siemens Extra 330LE*. En un futuro próximo estaremos hablando de aviones híbridos y eléctricos comerciales como el *Eviation Alice* y el *E-Fan X*.

PARAMETRIC STUDY OF ELECTRIC MOTORS AND GENERATORS FOR HYBRID PROPULSION SYSTEMS IN THE AVIATION INDUSTRY

Author: Ruiz Lozano, Laura.

Director: Norverto Moriñigo, Juan.

Collaborating Entity: ICAI – Universidad Pontificia Comillas.

ABSTRACT

This work approaches a preliminary study of the new technologies to be implemented in the current aviation. More specifically, this study wants to get to know more in depth the new methods of power generation within aircraft. Electrification of the propulsion systems.

Aviation has been subject to all sorts of changes and advances throughout history, but in recent years the greatest challenge has been to reduce emissions of pollutant gases. When focusing on future environmental goals in commercial aviation, there exists a compromise between many aspects that need to be taken into account: feasibility, fuel consumption reduction, safety and reliability and noise reduction.

All of this, with the help of new technologies it leads us to the use of high-speed electric machines to replace current combustion engines. From the results obtained, the best option came out to be the Permanent Magnet Synchronous Machine (PMSM) as it has the highest efficiency, power density and the one with the lowest mechanical losses, making it one of the most suitable for working in a wider range of high speeds.

One of the keys for launching this type of projects is the advantages that have towards the consumers. The new aircrafts offer cheaper tickets, less noise and a higher climb rate. With electric engines, these airplanes can maintain performance at higher altitudes where air resistance is lower, unlike combustion engines that operate less efficiently at these altitudes.

For this reason, many aviation companies and start-ups began to develop new technologies in order to meet the objectives. The biggest investor in this kind of technology is Airbus. The evolution of this kind of technology starts in 2010 with the development of some models such as the Colomban Cri-Cri, the E-Fan family and the Siemens Extra 330LE (2014-2016). On a future horizon, we can start talking about the Eviation Alice and de E-Fan X, two models that are starting to evolve in the right direction, to a more commercial aircraft design.

Acknowledgements

To all my teachers and friends from school who did of these 4 years an unforgettable experience.

To my teacher Luis Mochón who helped me unconditionally throughout the development of the project.

To my family.

Index

Table of figures	VIII
Graphs	IX
1 Introduction and state of the art.....	1
1.1 History and evolution of aviation	1
1.1.1 Definition.....	1
1.1.2 History of aviation	1
1.2 State of the art	3
1.2.1 Challenges	6
1.2.2 Current energy situation	9
2 Project objectives	9
2.1.1 Hybrid electric propulsion – present.....	9
2.1.2 The electric aircraft	12
2.2 High-speed electrical machines	15
2.2.1 Limitations of high-speed electrical machines.....	16
2.2.2 Critical evaluation.....	23
2.3 Permanent magnets.....	24
2.3.1 Specific aspects	24
2.3.2 PM Synchronous Generator types	26
3 Electric aircrafts: future of aviation and commercial flights	27
3.1 Colombian Cri-Cri	29
3.2 E-Fan 1.0.....	30
3.3 Siemens Extra 330LE	31
3.4 Eviation Alice	33
4 Future projects.....	34
4.1 E-Fan X.....	35
4.2 Take-off study.....	38
4.3 Preliminary calculations	49
5 Findings and conclusions	50
6 Bibliography	52
7 Annex I: Motor REG 30 BLDC	i
8 Annex II: MATLAB program coefficients	ii

Table of figures

Figure 1: Schematic plan illustrating an embodiment of the hybrid engine	6
Figure 2: Actual milestones of aircrafts distributed propulsion technology	7
Figure 3: Boeing 747	8
Figure 4: Electric propulsion architectures. Source: The National Academies Press [54]	11
Figure 5: Electrical Airplane Propulsion - when realizing that additional power was required for take-off and reducing aircraft's runways	12
Figure 6: Electrical system weight (300-seat aircraft) [18]	13
Figure 7: Turbofan engine weight as a function of replacement shaft power. Source: NASA.	15
Figure 8: Microturbine synchronous generator, 200kW and 21000rpm	16
Figure 9: Hysteresis curves of different magnetic materials. Source: Hyper Physics [39]	25
Figure 10: Hysteresis loop of ferromagnetic material. Source: [48]	25
Figure 11: PMSG cross section: a) with slot; b) no slots	27
Figure 12: Evolution in time of electrical power generating. Source: Roland Berger estimate [50].....	28
Figure 13: Airbus E-Fan 1.0. Source: Airbus	31
Figure 14: Eviation Alice at the Air Show Le Bourget, Paris	33
Figure 15: Taking-off phases	38
Figure 16: Aircraft's geometry. Source: google photos.....	40
Figure 17: Thickness/chord ratio. Source: Aviation Dictionary, 2014	42
Figure 18: Graph representing our points of interest. Source: ASA [19]	42
Figure 19: Wing cross-section. Source: ASA [22]	42
Figure 20: Lift coefficients for angles of study. Source: MATLAB.....	43
Figure 21: Free body diagram. Source: Despegue y aterrizaje.....	44
Figure 22: Curvilinear and rectilinear phases.....	46

Graphs

Graph 1: Pout vs. rotor diameter (d). Source: IEEE Xplore [35]	19
Graph 2: HS-index showing electrical machines in function of their index vs speed. Source: IEEE Xplore [35].....	20
Graph 3: HS-index vs. Pout of different machines. Source: IEEE Xplore [35].....	20
Graph 4: Power vs speed. Source: own production [36]	21
Graph 5: HS machines nominal power vs. speed. Source: IEEE Xplore [27].....	22
Graph 6: HS machines plotted with G-index limits. Source: IEEE Xplore [29].....	22

1 Introduction and state of the art

1.1 History and evolution of aviation

1.1.1 Definition

The aviation or aeronautic engines are those used to propel the aircraft thanks to a moving force, making them move forward. The major difference with those in automobiles or ships is that these engines are mainly made with much more resistant and compact materials needing them to be lighter, making its production much more expensive. In fact, there are two basic kinds of aircraft engines: piston engines and reaction ones, where turbines are included. Major energy and aviation institutions, such as NASA, carried out investigative studies to design a new electric engine in an attempt to reduce fossil fuel consumption and environmental impact. [1]

1.1.2 History of aviation

Flying has always been in human's mind since the beginning of time. The desire to feel like a bird started when the first men observed how these magnificent creatures flew over the horizon.

Throughout history, there has been many attempts to fly the skies, but many of them ended catastrophically: some men tried imitating birds by using armours, wooden frames and many other materials in a way of replicating their wings. Others tried replicating the animal itself but all of them became failed attempts.

Even if it's unclear who was the first person who fully dedicated itself to the investigation of this aircrafts, Leonardo Da Vinci (1452-1519) was the first one to design a glider. The mechanisms that his artefact used were very similar to the ones that the birds used for flying. Even if it was never built, the designs were kept and used later around the XIX and XX centuries.

Since Da Vinci's death many attempts to fulfil the desire to fly where developed: in 1670 Francisco de Lana Terzi (1631-1687) tried to develop a device lighter than air with the help of a candle. The idea was never developed into a real thing, but further in history it was discovered that hydrogen was lighter than air, making it possible to make something "float" in the air with the help of this noble gas. In June 1783, two French scientists, Joseph-Michel Montgolfier (1740-1810) and his brother Jacques Étienne Montgolfier (1745-1799) were able to levitate a balloon over Annunay's city (France). In

September of that same year, in presence of the king Luis XVI and María Antonieta, these two scientists were able to make a balloon fly 2km, carrying in its basket a chicken, a duck and a lamb.

The next step was taken by the English engineer George Cayley (1773-1857), considered the father of aerodynamics. He invented the glide, an artefact capable of maintaining itself “floating” or sustained in air with the help of the raising currents of hot air. It had no motor, so it wasn’t able to take-off by itself. In 1853, a friend of the scientist was the first man to fly with one of his glades and he did it over Scarborough, English Yorkshire.

Due to all the failures that these “planes” encountered, William Samuel Henson (1812-1888) another scientist that followed really closely Cayley’s work, invented an aircraft capable of taking-off and lifting itself in air. This plane was equipped with a steam engine, a propeller and one single wing, patenting it in 1842.

The first greatest step in the aircraft’s history was made by the German physicist and inventor Gustave Whitehead (1874-1927) as he managed successfully to take off and land the first crewed aircraft on August 14th, 1901. He was able to repeat the process three more times. The Wright brothers managed something similar on December 17th, 1903.

This became a turning point in the evolution of aircrafts, continuing to move forward by leaps and bounds. As an example, in 1909 a flight that crossed the 38km that has the English Channel, in less than 40 minutes, was successfully executed.

Nevertheless, WWI became a key point in aviation, as it triggered off the professionalization of the aeronautical production and was the beginning of what nowadays is known as one of the most powerful industries on earth. At this point, planes were able to rise themselves 6 hundred meters and they were used as weapons.

From this point in history, the development of a civil aviation didn’t take long, as in January 1914 the first airline appeared in the Unites States, serving with a hydroplane. Four years after, civil aviation started to accept passengers, especially in Europe.

The first transatlantic flight took place in 1919, and in 1927 for the first time in history, the flight New York – Paris was carried out in about 33 hours.

With all these new technological advances, around the thirties and forties, new kind of aircrafts started to be developed until the ones that we know nowadays.

1.2 State of the art

These days, air navigation contributes around a 2% to the atmosphere's CO₂ emissions. This fact, together with the predicted increase in air traffic for the next few years made manufacturers, airlines and air navigation service providers combined their efforts to try and achieve a more efficient and environmentally friendly sector. An issue at the forefront of global warming is the carbon footprint. The carbon footprint is generated from the emissions caused by our daily activities expressed as carbon dioxide equivalent (CO₂eq). [1]

The evolution in the mechanical and hydraulic aircraft's system is one of the most advanced sectors at this moment. They are trying to evolve them to a more electrical and electronical systems, making the aircraft lighter and more reliable, requiring less maintenance, always striving for a More-Electrical Aircraft (MEA).

As an example, at the very beginning of aviation, the flight control systems were mainly controlled mechanically from the cabin. The systems only depended on the pilot's strength, making it really hard, in some occasions, due to aerodynamic forces. These forces increase with the aircraft's speed, so when this one was flying fast, the systems were almost impossible to control. For this reason, Airbus designed an electrically controlled system named "*fly-by-wire*" in its A320 aircraft. By all accounts, it has been a resounding success, so great that from this point aircrafts started to electrify themselves. One good example of this is Boeing 787 Dreamliner, where the hydraulic and pneumatic systems such as the cabin's pressurization or the anti-icing systems are completely electrified.

Modern aircrafts are mainly sustained by electrical systems, in a more efficient and reliable way. But evolution now comes in the engine sector. The whole purpose of designing an engine that works mainly from electricity, is to reduce significantly our environmental trail. [2]

Currently, all gas turbines are designed to meet all flight needs and therefore the design is more about a compromise between needs and requirements rather than having a very optimized configuration. If we are able to split the use of the gas turbines into generating electricity, we can optimize the turbine into becoming a more efficient and reliable component in the aircraft system. [3]

Nowadays, the electric generation coming from generators coupled to gas turbines, in the aviation industry, is a complete mystery. Within the scope of this project we are trying to establish some basic design rules and formulas in order to explain what main factors determine the good functionality of producing enough electricity from a gas turbine to propel an airplane.

Some of the following patents will help us acquire a more global image of what is that we are trying to obtain.

- “HYBRID ELECTRIC PROPULSION SYSTEM USING A DUAL SHAFT TURBINE ENGINE” (ref. US5762156A)

This patent talks about a hybrid system with an electric drive motor for vehicles. This was one of the first approaches to hybrid propulsion within cars. The idea was to have a generator which supplies electric current to the motor. The main idea behind the dual shaft turbine engine is to have in one of the shafts a compressor and a gasifier, whereas in the second shaft there will be coupled a power turbine, flywheel and the mentioned generator, which is the one in charge to provide the electric current. Both shafts spin independently from one another. The basics of this assemblage is to take advantage from the exhaust gases that will be in charge of turning the second shaft with the power turbine. The generator and the flywheel will be turned as a unit providing the electric power to the vehicle. [4]

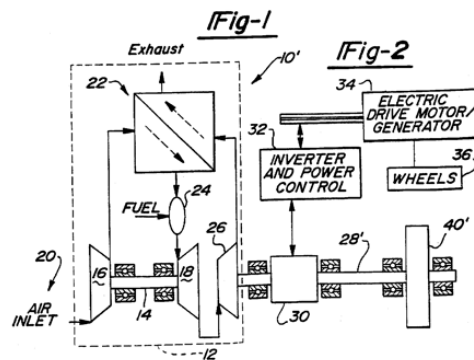

- “HYBRID PROPULSIVE ENGINE INCLUDING AT LEAST ONE INDEPENDENTLY ROTATABLE COMPRESSOR ROTOR” (ref. US 8,596,036)

In this second patent, the electrical power generated is used in an aircraft configuration. The hybrid propulsive method is used to provide thrust with the flow of a fluid (air) through an axial flow jet engine. This engine is coupled to a generator for the sole purpose of partially extracting energy – electrical power – from the working fluid. This electrical power will be then converted into torque to produce thrust during inflight operations. The extraction of energy is done mechanically. The fluid will move a rotatable

element, that at the same time, this is coupled to an energy extraction mechanism that will convert part of this mechanical energy into electrical one. [5]

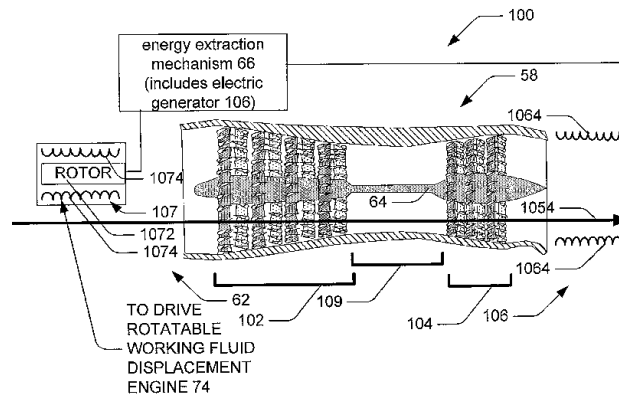

- “AIRCRAFT HYBRID ENGINE” (ref. EP 2 998 557 B1)

This patent attempts to recreate a propulsion engine. In this example, the invention is formed of two shafts, two fans encased by a geared ring, one electric motor, a storage device and a gas turbine. The gas turbine is the one in charge of driving the first shaft that, at the same time, moves the first fan. As both fans are coupled by the geared rings, if fan one moves, the other one moves too. At this time, both shafts will be rotating.

The electric machine can work in two different scenarios. The first one would be working as an electric motor, extracting energy from the electric storage device to drive the second shaft. Second scenario is as an electric generator, extracting the mechanical energy of the rotation of the second shaft in order to charge the electric storage device.

In Figure 1 we can observe that there is an intermediate gear connected to a linear actuator between both fans in order to transmit the torque between them. In case of a mechanical failure, the role of the actuator is to disengage the mechanical connection.

As the patent states, this invention is intended for aircrafts but can also be used by other vehicles. [6]

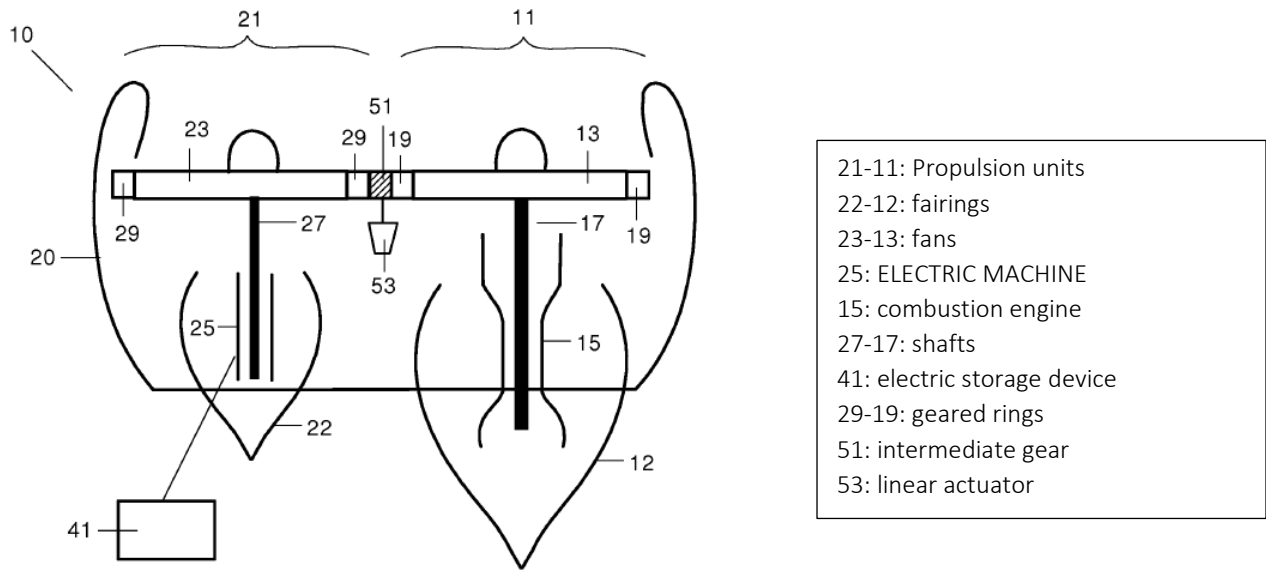

Figure 1: Schematic plan illustrating an embodiment of the hybrid engine

These patents describe an evolution of hybrid propulsion engines, which are related to the scope of the current study that will be executed. The study of these three patents will be the starting point of the project.

1.2.1 Challenges

When focusing on future environmental goals in commercial aviation, there exists a compromise between many aspects that need to be taken into account: feasibility, fuel consumption reduction, safety and reliability and noise reduction. As air passengers won't stop growing, the impact of the effects of using propulsion systems in commercial aircrafts is becoming more and more important. For the time being, we don't have the magic formula to make any machine fuel independent. The only steps that we can give toward electrification is to gradually increase electric components and progressively remove those components or features that have the greatest negative impact both in environment and financial matters. [7]

Aviation in the 21st century is not only limited by technological constraints but also it is subjected to environmental ones, dictating the nature of the aircrafts of the future [1]. One of the most favorable propulsion systems considered for future aviation is the aircraft distributed propulsion.

A really accurate definition of distributed propulsion (DP) could be found "Distributed propulsion can be broadly defined as distributing the airflows and forces generated

by the propulsion system about an aircraft in such a way as to improve the vehicle's aerodynamics, propulsive efficiency, structural efficiency, and aeroelasticity" [8]

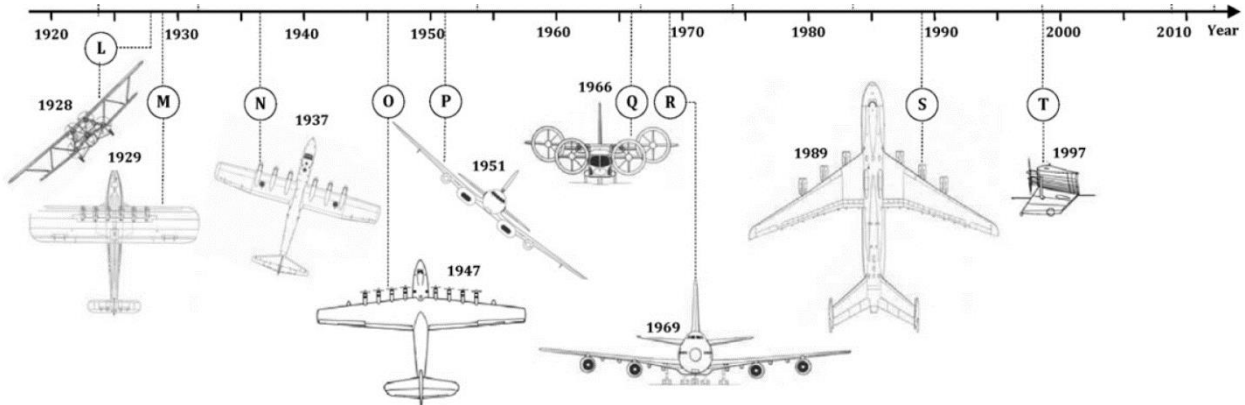

Figure 2: Actual milestones of aircrafts distributed propulsion technology

- Historical review of distributed propulsion technology

For a better understanding of what this type propulsion system this is, we should take a look back in history. The main principle of distributed propulsion is to divide up the thrust in an attempt of reducing noise and making shorter take-offs and landings. Along the historical axis of time, we found some examples of how these systems were employed with the available technologies of their times.

Dornier Do X (Figure 2 – M) in 1929 was one of the largest aircrafts ever built before. This machine was intended to cross the Atlantic Ocean from Germany on November 1930, flying to various destinations before reaching New York on the 27th August 1931. This aircraft was equipped 12 engines each of them with faired-in engine supports. Within its journey, the Dornier Do X encountered several technical difficulties, being the engine cooling one of the main issues. The heating of each of the 12 engines caused a thrust reduction for the rear engines. This would be solved within the following years. [9]

Running along the timeline, in 1937, Blohm und Voss BV 222 Wiking (Figure 2 – N) was the largest operational flying-boat during WWII. Designed for the transportation of passengers, it was equipped with six vertically opposed engines distributed over the wing [10]. In 1947, H-4 Hercules was created following the same design as the Blohm und Voss BV 222 Wiking due to its success. This time, the plane consisted of a single hull and eight radial engines, it was also employed metal instead of the conventional wood due to its considerable size. When operated, the aircraft presented various technical problems

such as the integration of power systems [11]. These problems were summed to the previous ones; the cooling of the engines in distributed propulsion systems.

One of the most commonly known airplanes, Boeing 747 (Figure 2 – R) had its first flight in 1969. This one used four turbofan engines in pods pylon-mounted on wing leading edges, equipped with air-cooled generators [12]. Technological advances in the Boeing 747 were evident in comparison to the Dornier Do X's engines, becoming the standard configuration to modern commercial aircrafts.



Figure 3: Boeing 747

Right at the end of our timeline in Figure 2, in 1997 we find the first solar-powered aircraft. This airplane could reach altitudes of 30km, with a wingspan of 61.8 meters integrated with 14 brushless direct-electric motors [13]. Thanks to the development of this aircraft and its environmental impact, new environmentally friendly considerations were taken into account for future propulsion systems.

There only exist two alternatives. Electrification or the use of alternative fuels. For many decades it was believed that crude oil was going to be infinite, and even more important, cheap. Both statements were revoked scientifically, so now is time for scientists to look up for feasible solutions in order to be able to continue with our lifestyle before running out of natural resources. [1]

In fact, there's been existing alternatives for some time now, but these were marked by crude oil's prices. Many sceptics don't believe in the fact that before WWI, the existence of electric cars was real, but the petrol engine gained popularity and the electrified ones were left behind.

The most commonly known alternatives are the ones that substitute the use of crude oil. Some examples of alternative fuels are fuel cells, solar impulse, the use of hydrogen and biofuel.

1.2.2 Current energy situation

The energy situation, both global and national, is conditioned by the gradual consumption of fossil fuel reserves, growing environmental awareness and the geopolitical situation. The economic growth and prosperity of the first world since the industrial revolution is strongly related to the use of fossil fuels.

These fossil resources tend to decline, as they are consumed at a much faster rate than they are replaced. Some experts believe that the decline in fuel production will have a drastic impact on modern technological civilization as this is heavily dependent on oil for petrol. This energy situation particularly affects the transport sector, which is the largest energy consumer, with 41%, ahead of other sectors such as industry. As electric cars are a reality in our daily life, aviation wants to place themselves at the same level, despite the difference in fuel consumption.

Focusing in Europe, transport accounts for a quarter of greenhouse gas emissions and 36% of energy consumption. For all these reasons, European emissions standards has been defined, which regulates the acceptable limits for exhausted emissions from new vehicles sold in the Member States of the European Union. Emission standards are defined in a series of progressively implementing European Union directives, that are becoming increasingly restrictive. [14] All these restrictions were thought to reduce the 90% of transport emissions caused by cars, but aviation causes the 2%, it seems negligible, but when taking in tons of CO₂ a 2% needs to be reduced.

2 Project objectives

Within the scope of this project, we are going to study the current industry of hybrid and all-electric aircrafts in order to acquire a broader knowledge of the actual technology applied. The aim of gathering all this information is to be able, in a future project, to dimension an electric machine capable of connecting to the turbofan of an aircraft with a view to propel the ship with only electricity, achieving a reduction in the consumption of fossil fuels.

2.1.1 Hybrid electric propulsion – present

Hybrid technology appeared around the XIX century with Nikolas August Otto who saw the electric motor as a great invention that would, one day, complement the classic gasoline engine.

The concept of hybrid systems started developing in the XIX when scientist started to investigate, more in depth, how to generate energy with the resources they had, as extracting fossil fuels was extremely complicated at that time.

All of them tried complementing the alternating current, the most common way of energy transmission used, with a gasoline motor. With this they were trying to combine both in a way that when one was at maximum power, the other would store the energy that could afterwards be required.

Many scientists developed this brilliant idea, but not many succeeded in the attempt. In 1828 the first hybrid model was developed but couldn't be considered a hybrid vehicle. It wasn't until 1832 to 1839 that a real hybrid vehicle was designed and successfully developed by Robert Anderson. This last design was improved by Thomas Davenport and Robert Davidson when he introduced the rechargeable battery.

Until 1859, once the battery ran out it became useless. Until a French scientist, Gaston Planté, invented the acid-lead battery, being the first rechargeable battery that ever existed.

From this point in history, many advances took place in the hybrid industry. Many prototypes were built but many of them didn't succeed. It wasn't until 1900 when Ferdinand Porche produced the first hybrid vehicle. His car was considered the first hybrid vehicle in the world, being also the first vehicle with front-wheel drive having an autonomy of 64km using only the electric energy stored in the batteries. Finally, in 1911, the fist hybrid car was put on the market, becoming a failure due to the conventional gasoline motors that already existed. People didn't want to change due to their little understanding of this new technology. [15]

- What's a hybrid vehicle?

A hybrid vehicle is any vehicle that uses two motor sources. This one includes a sailing boat (wind/motor) or any that uses an engine (diesel/electric). For the automobiles, a hybrid is the one that uses an internal combustion engine and an electric motor feeding the batteries. This reality started to become popular with the oil crisis, due to the cheapening of technology and the environmental awareness.

Hybrid propulsion systems are not the only solution but is one of the most feasible solution to our present and near future problems, thanks to the huge advances in alternative energy sources.

Not only cars can take advantage of this new advances in hybrid technologies. As mentioned previously, this hybrid technology started to develop in cars but nowadays many experts are trying to expand this idea into other fields of study, aircrafts.

The main issue with aircrafts is that the electric motors and batteries need to be able to provide the same thrust and power as the gas turbines that they are trying to substitute. For this reason, as technology is not that advanced yet, the most feasible solution is to use a combination of gas turbines and electric motors/generators in order to reduce harmful emissions and noise.

Therefore, a general classification was done within electrical propulsion commercial aircraft.

- All electric
 - Hybrid electric
 - Parallel hybrid
 - Series hybrid
 - Series/parallel partial hybrid
- Turboelectric
 - Full turboelectric
 - Partial turboelectric

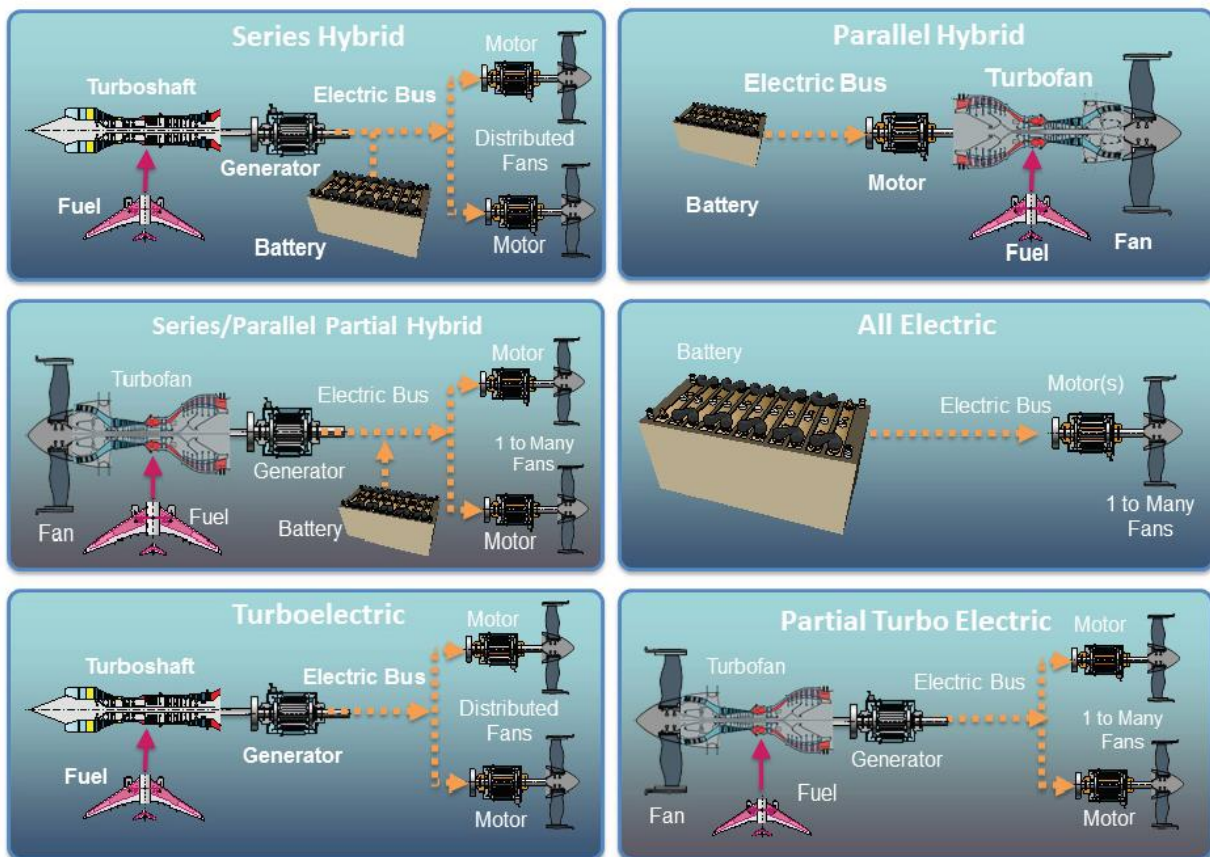

Figure 4: Electric propulsion architectures. Source: The National Academies Press [54]

2.1.2 The electric aircraft

More advanced electrical systems are being introduced in commercial aviation. In an electric aircraft, combustion engines are being substituted by electric motors. If we trace the electric aircraft evolution, in 1943 was proposed the first electrical airplane propulsion system (Figure 5) which drove multiple rotating propellers. [16]

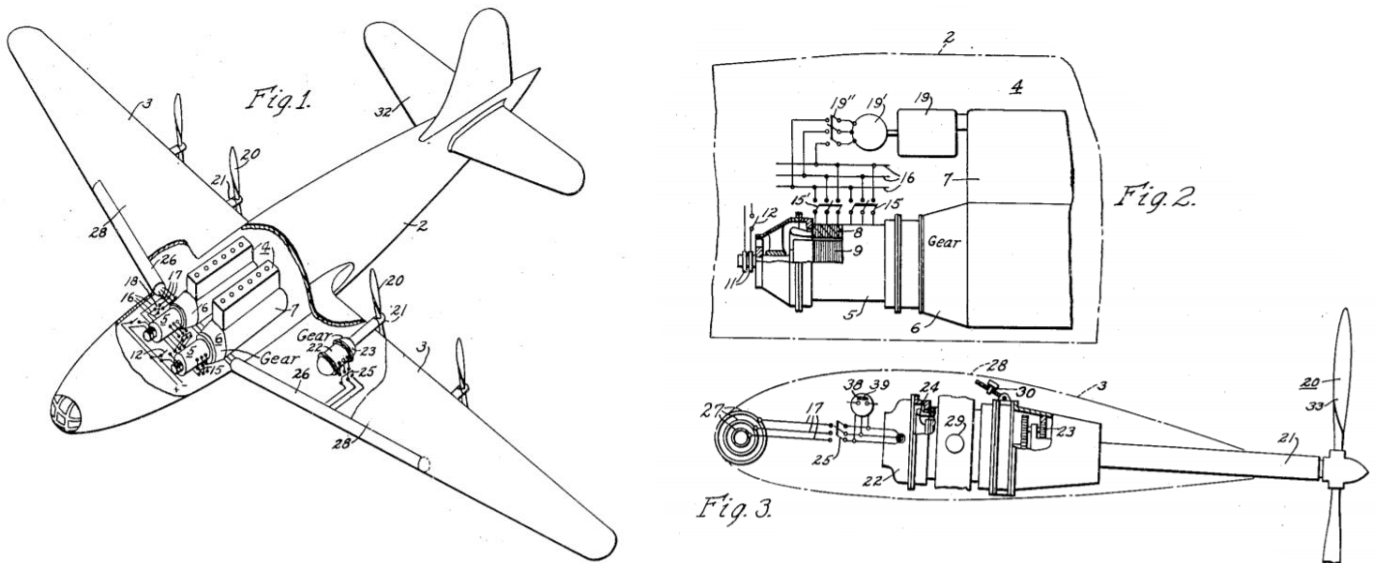

Figure 5: Electrical Airplane Propulsion - when realizing that additional power was required for take-off and reducing aircraft's runways

Within the electric aircrafts we can identify two types: More-electric aircrafts (MEA) and All-electric aircrafts (AEA). The MEA appeared as a solution to overcome the challenges that AEA entails. Some of the advantages of pursuing an electric aircraft are the possibility of reducing by around 10% the empty weight of a typical airliner [17] and a considerable reduction in Specific Fuel Consumption (SFC) [18]. With some of the advantages in our head, the electric power system used a 115V with 400Hz for large loads [2]. In terms of losses, higher voltages are preferred as losses are proportional to the square of the current.

$$P = I \cdot V = \frac{V^2}{R} = I^2 \cdot R \quad (\text{Eq. 1})$$

In addition, attention should be paid to the aircraft configuration itself. This could become an issue to AEA or MEA as many parameters such as the SFC, mass, overall fuel savings and power demands are subjected to design specifications, aircraft engine type and number of engines.

- General properties

Within the scientific community, there exist some basic principles of electric motors. The following list resumes seven common properties of electric motors identified by Hughes [19]:

1. Speed is proportional to output power per unit volume
2. Large motors have a higher specific torque and are therefore more efficient than small ones
3. Motor efficiency improves with speed
4. A motor can be modified for any voltage
5. Most motors can stay overloaded for short periods without being damaged.
6. The output from any given motor is constrained by the cooling arrangement
7. Motors with similar cooling systems have a rated torque almost proportional to the rotor volume (roughly the overall motor volume).

With this said, weight plays an important role in an airplane. When identified the weight percentages of each of the electrical component of a 300-seater aircraft, it was evident that the generators (26%), motors (15%) and electrical cables (30%) dominated the electrical weight. Figure 6 give a good visual understanding of how each of these weights contributes to the final weight of the aircraft. [18]

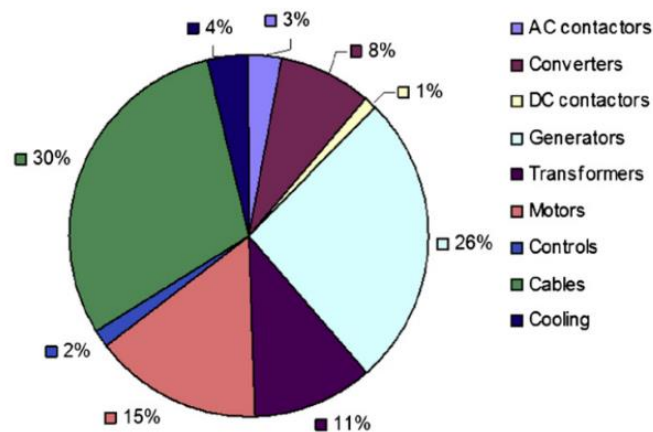

Figure 6: Electrical system weight (300-seat aircraft) [18]

- Weight

One of today's biggest problems is that no conventional electric motor power densities could be compared to those of today's gas turbine aircraft engines. When comparing an electric-motor-driven-fan system with a turbofan engine, a direct comparison cannot be made. Some decision must be done, as how much power must the motor produce, not to mention how much of the turbine engine is replaced. When

converting into equivalent terms power and weight, great attention must be made. Consequently, researchers at the NASA Glenn Research Center addressed several issues relating to this comparison. [20]

1. When looking up for the turbine engine's weights, they usually include the propulsor (propulsive fan and related components). These propulsor components would also be required in the electric motor drive. It was stated that the propulsor components represented a 30% of the total engine weight.
2. The power supplied by the motor to the propulsive fan, is not published. Instead, we know about the total turbofan engine thrust (sea-level static takeoff thrust).

$$T_{tot} = T_{fan} + T_{jet} \quad (Eq. 2)$$

Having knowledge of this, a relation could be derived. From engines between 15.000lb and 100.000lb thrust, a relation between the total engine thrust (in pounds) and the fan power (in horsepower) could be made:

$$P_{fan} = 1,25 T_{tot} \quad (Eq. 3)$$

3. When dealing with the jet thrust, there is one in a turbine engine but not in an electric-motor-driven fan. If we were to substitute the turbofan engine that drives the fan with an electric motor, within the same operational conditions (speed and torque), the final thrust would be much lower than the total thrust coming from a turbofan engine. A relationship between T_{fan} and T_{tot} would be:

$$T_{fan} = 0,8 T_{tot} \quad (Eq. 4)$$

With all these assumptions and approximations, we can't expect to be using the same dimension fan used in a turbofan engine in our electric-motor-driven fan. This fan would be a 20-25% bigger than the conventional one used nowadays in turbofans.

In terms of weight, when all the above factors are combined and applied to an engine we can obtain the following relation:

$$weight = 0.137(Power)^{0.9249}$$

(Eq. 5)

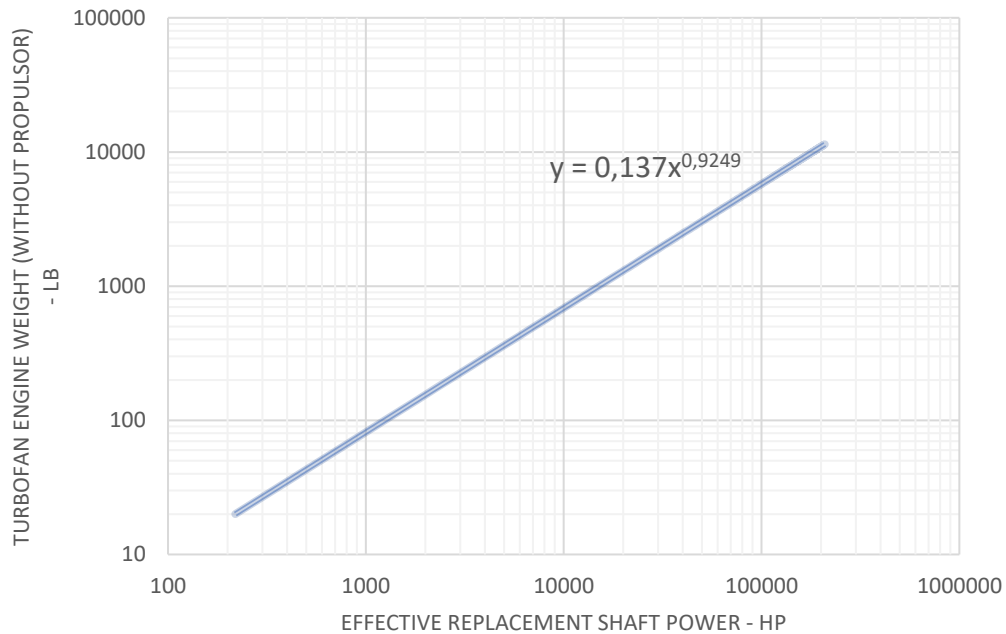

Figure 7: Turbopan engine weight as a function of replacement shaft power. Source: NASA.

2.2 High-speed electrical machines

Inside the project objectives, we need to study the electrical machines and their functioning, to establish their viability within the aviation sector.

Direct current synchronous machines and induction ones have a wide range of industrial applications such as traction, pumping, control, etc. However, the electric power system's operation requires the conversion of large quantities of primary energy into electric energy and power. Electric power can be transmitted and converted into a more clean and economic form of energy. So, for this reason, the synchronous machines are the most widely used to carry out these tasks.

Regarding the mechanical operation, these machines could be designed with a smooth rotor (2-4 poles) when they need to operate at high speeds or a salient pole rotor (20-100 poles) when working in lower speeds.

Most of the synchronous machines are used as generators in electric energy production plants due to their high efficiency and the possibility of controlling their tension. As many other electromechanical converters, the synchronous machine is completely reversible, being more and more commonly its use as it has many advantages. The drawback that could be found when used as a motor is that it does not produce a starting torque. For solving this issue, focusing on an induction motor, a squirrel cage auxiliary winding in the rotor helps reaching an acceleration torque up until synchronous speed, with the objective of synchronising the machine to the grid. [21]

Further down on our study, we are going to focus on *high speed electric machines*, as these facilitates the elimination of mechanical transmission, presenting a wide range of advantages such as: higher power density, higher mechanical stiffness, less noise, volume and weight reduction of the machine, lower wear and lower maintenance costs.

These applications range from power between 0,1kW up to 10MW, with rotation speeds from 10.000 rpm to 500.000 rpm. One of the things that we need to consider, is that the high-speed concept comes bounded to the peripheral or tangential speed of the rotor (v – [m/s]), not to the rotating speed (n – [rpm]). [22]

We are going to firstly specify the possible limitations of high-speed electrical machines and then we will state some examples of synchronous generators, trying to elaborate a critical assessment of high-speed synchronous generators.

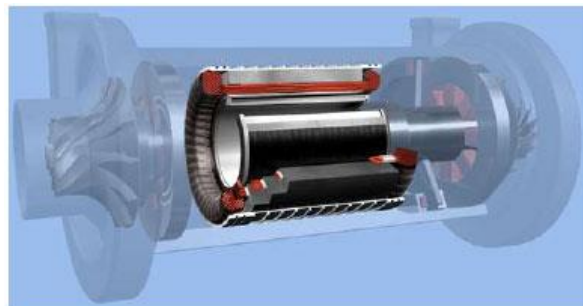

Figure 8: Microturbine synchronous generator, 200kW and 21000rpm

Source: e + k Elektromaschinen und Antriebe - Switzerland

2.2.1 Limitations of high-speed electrical machines

High-speed electrical machines present a series of mechanical and thermal limitations, besides there are some restrictions imposed by the electronic power converter, affecting their design.

- LOSSES

There exist three type of losses in an electrical machine: magnetic, electrical and mechanical, all of them increasing significantly with the increase of rotational speed. In synchronous machines, the relation between frequency (f – [Hz]), rotational speed (n – [rpm]) and the number of pares of poles (p) is given by the following equation:

$$p = \frac{60 \cdot f}{n_s}$$

The copper losses – *electrical losses* – are due to the overheating of the electrical conductors as a result of the joule effect. These losses vary with f^2 making it ideally to use twisted conductors or Litz conductors within high-speed applications. Iron losses – magnetic losses – are considered as a whole, losses due to hysteresis. They vary approximately with the product of the magnetic induction squared and the frequency squared ($B^2 \cdot f^2$). Against this background, the magnetic plate requires to have very low specific losses of iron with small thickness or special magnetic materials. [23]

The *mechanical losses* are mainly caused by air friction and the friction caused by the bearings. Losses increase proportionally with the rotor speed, that's why it's of a significant importance to do a good selection of the materials that are going to be used in its construction. [24]

All these details are only stated but won't be developed as this area of investigation is not the one we are following in our study.

- MATERIALS AND DIMENSION CONSIDERATIONS

Running in such high speeds derives in huge mechanical efforts in the rotor due to the centrifugal force. This force is expressed in terms of the material's density and the tangential speed ($\sigma \sim \rho v^2$). From this it could be deduce that the size of the rotor's diameter depends on the rotor's material elastic limit, maximal tangential speed and the maximum value of the rotational speed [25]. This makes a complicated task to choose which materials should be chosen for the construction of the rotor, as the ones with a high elastic limit and low density are not magnetic. The rotor's design should also always consider the natural resonant frequencies, to prevent unwanted vibrations. [26]

- BEARINGS

As stated before, bearings play an important role in mechanical losses, so that's why special attention should be paid to the use of bearings in synchronous machines. These machines need to be able to work in a stable way and throughout long periods of time at elevated speeds, so for this reason different types of bearings are used: mechanical, fluid type (liquid or air) and magnetic bearings, being the magnetic or fluid bearing the most suitable for high-speed machines. [25]

- DESIGN CONSIDERATIONS

For optimizing the design of these alternating current electric machines, is sometimes useful to start with the expression of the rated power in the air gap.

$$S_{\delta} = \left(\frac{\pi^2 \sqrt{2}}{120} \right) \cdot k_w \cdot A \cdot B \cdot D^2 \cdot L \cdot n$$

With:

k_w : Winding factor ($\sim 0,9 - 0,95$)

A: Specific electric loading – SEL – [A/m]

B: Specific magnetic loading (air gap flux density) – SML – [T]

D: Diameter of the rotor – [m]

L: Axial length – [m]

n: Rotational speed – [rpm]

As a consequence of increasing the speed, resulting in greater mechanical efforts, the dimensions of the machine decreases. At the same time, to limit heating and the losses, the SML (B) and SEL (A) also decreases. Therefore, the output power decreases proportionally.

Two indicative indexes were determined to try and classify the different types of machines in function of their rated power and rotational speed. The first one is called the HS-Index (High-Speed) and was proposed by Moghaddam (2014) while the second one was suggested by Gerada (2014) being the G-Index. Many other authors established a correlation between power and speed but due to the continuous improvements in this field, they had become less relevant to new studies.

HS-Index relates the rated power (MW) with the rated rotational speed (krpm)

$$HS = n \cdot P_{out} [MW \cdot krpm]$$

The value of this index number becomes significantly regarding the output power capability due to the rotational high speeds. It has been stated that for relatively low speeds, $n < 20.000$ rpm, mechanical stress in the rotor becomes the main limitation factor, whereas in higher speeds ($n > 20.000$ rpm) could be found additional losses, stabilising a limit in the maximum power capability. Below 20.000 rpm, HS is a function of the maximum rotor surface speed v_{max}^2 , being limited to 250-300 m/s and almost independent of the rotational speed (n). While in higher speeds it depends on the square of the rotational speed – $HS \propto v_{max}^3 / n^2$. The maximum power output is proportional to the rotor's diameter, almost cubically - $P_{out} \propto d^{2.6}$. [27]

$$n \times P_{out} \propto v_{max}^3 / n^2$$

$$P_{out} \propto (v_{max} / n)^3 \propto d^3$$

$$P_{out} \propto d^{2.6}$$

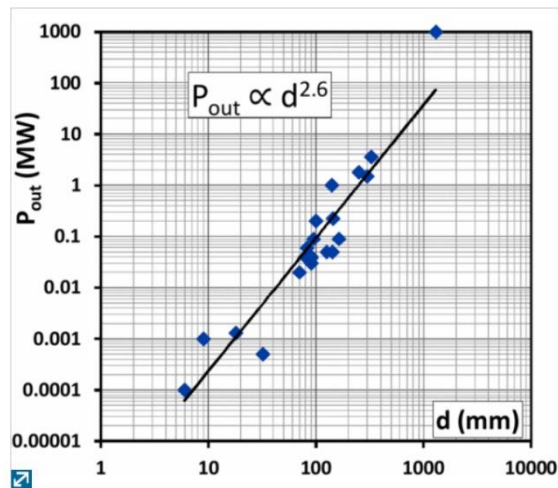

Graph 1: Pout vs. rotor diameter (d). Source: IEEE Xplore [35]

From the HS-index, many relations can be developed. Two of them are represented in Graph 2 and Graph 3. In these two graphs we can observe how the HS-index, from different type of machines, is proportional to P_{out} but inversely proportional to the rotational speed, n . What we can conclude from this is that when selecting a machine, we must keep in mind that if we want a high-speed rotational machine, we will have a low index, whereas the index will increase proportionally with the increase of the nominal power of the machine. HS machines are determined, not due to its high n (rpm) but to its high v (m/s). [27]

When trying to find some technical information from the machines, we have to bear in mind that confidentiality within the machine's dimensions and speed (v) information happens and they are not included in the public literature published.

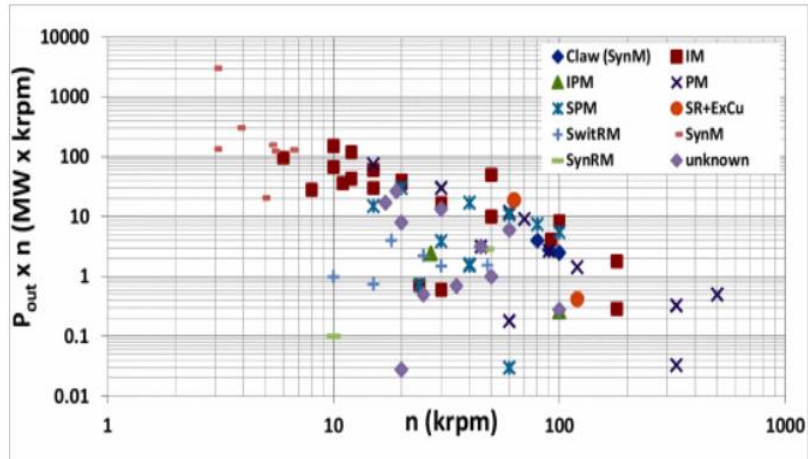

Graph 2: HS-index showing electrical machines in function of their index vs speed. Source: IEEE Xplore [35]

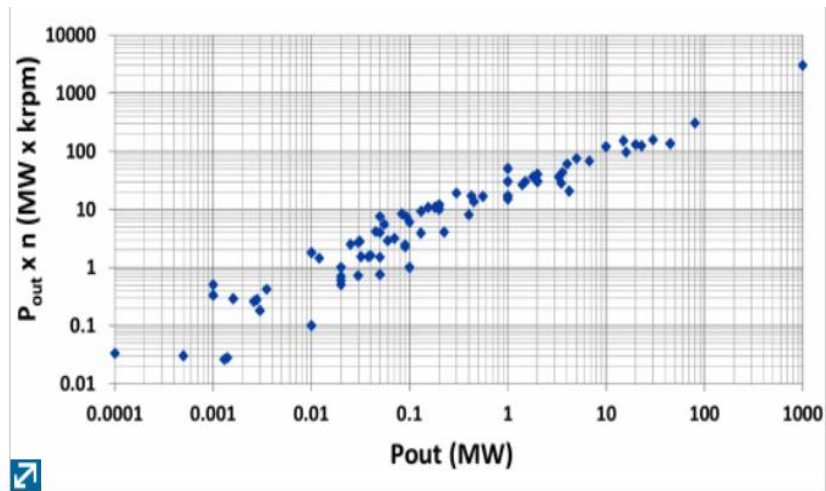

Graph 3: HS-index vs. Pout of different machines. Source: IEEE Xplore [35]

G-Index is used as an indicative index to determine the importance of dynamic problems that could occur in this type of machines.

$$G = n \cdot \sqrt{P_{out}} \quad [rpm \cdot kW]$$

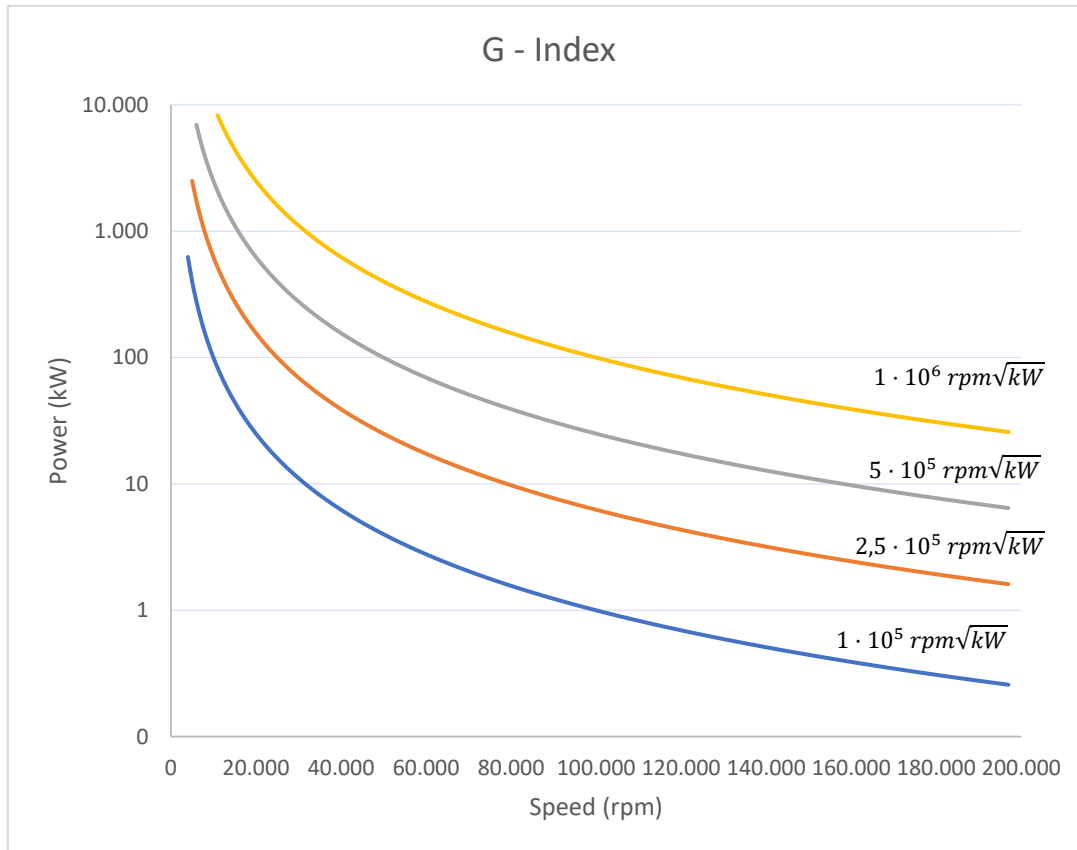

Graph 4: Power vs speed. Source: own production [36]

Dynamic problems could be considered negligible when $G < 10^5$, they obtain a level of importance when the index value is between $5 \cdot 10^5$ and 10^6 and we could say that they become quite severe when 10^6 is exceeded. [28]

Machine Technology	rpm√kW	m/s
solid rotor IM	1×10^6	400
surface PM with sleeve (no rotor laminations)	8×10^5	300
laminated rotor IM with high strength SiFe	6×10^5	280
SR with high strength VCoFe laminations	3.5×10^5	210
laminated rotor IM with normal SiFe	2.5×10^5	185
IPM with high strength SiFe laminations	1.5×10^5	230

Table 1: Summary of HS machine limits

If we plot in a graph different machines (Graph 5), we can observe the trend where, as we increase the machine's speed ($n - rpm$), the output power decreases significantly. This behaviour can be explained directly with the G-Index – Graph 4.

In Graph 6 we can compare both sources of information, HS machines along with the G-index limits. As we stated before, the limit where dynamic problems become acute is at the value of $G > 10^6 \text{ rpm}\sqrt{kW}$ and from Graph 6 we can see that no machine surpasses this limit.

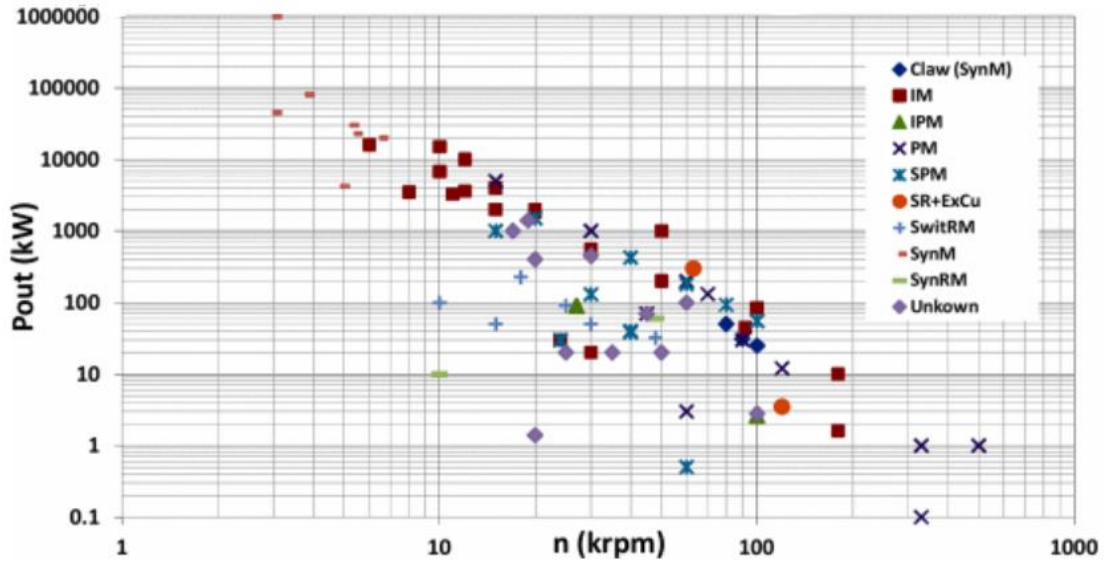

Graph 5: HS machines nominal power vs. speed. Source: IEEE Xplore [27]

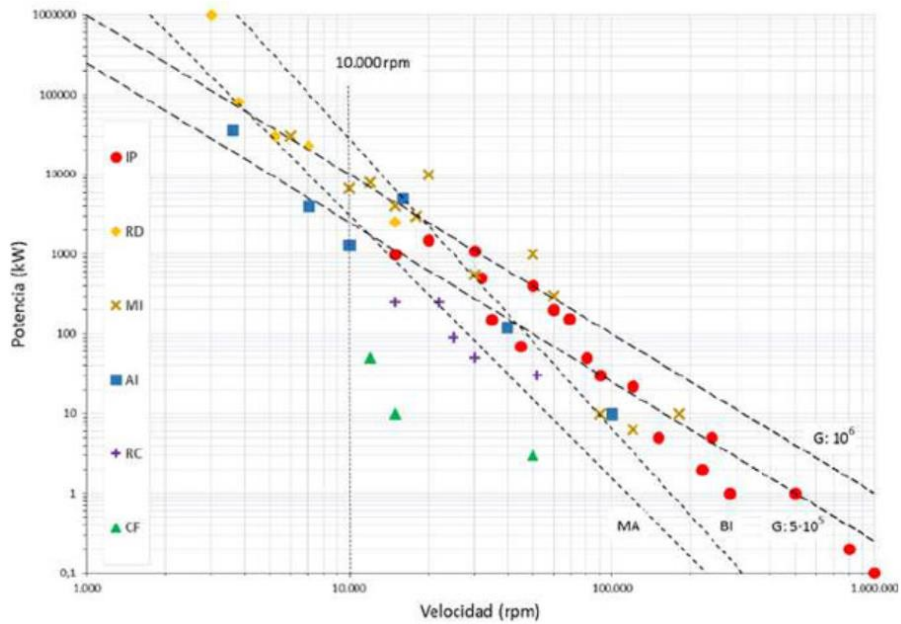

Graph 6: HS machines plotted with G-index limits. Source: IEEE Xplore [29]

All limitations considered constitute all kind of challenges that should be considered when designing high-speed electric machines, particularly dealing with

synchronous generators. When facing these limitations, some designing aspects should be taken into account. The most important ones are listed in the table below.

Mechanical	Use of the appropriate bearings prepared to withstand high speeds. Simplicity and robustness of the rotor. Rotor's dimensions limited by tangential speed. Magnets in the rotor should be perfectly fixed.
Electromagnetic	Minimize magnetic losses by using very thin laminations or special materials. Minimize electric losses by using twisted or Litz conductors. Use high-energy, high-temperature and resistant to demagnetization permanent magnets. Optimize the teeth and lot design in rotor and stator
Thermal	Use high thermal class electronic insulators. Simple and efficient cooling system
Other	Simple and compact design. Reliability. High efficiency. Reversibility to be able to work as a motor. Low production costs. Low-maintenance and wear resistant.

Table 2: Design considerations for HS synchronous generators

2.2.2 Critical evaluation

When trying to decide between machines, the election is strongly conditioned by their specific requirements (operation speed range and output power) and the final application for which is needed. As an example, we are going to mention the generators intended for aviation, two aspects to look at are reliability and power density.

A critical evaluation has been done by Fernando Martinez and Pere Andrada in their "High-speed Synchronous Generator" study [29]. In their evaluation they had taken into account many different types of machines and a various of requirements that helped them evaluate the viability of the machine. The criteria could be divided in 4 different groups: specific design requirements (simplicity, reliability, cost...), sizing parameters (power density, maximum peripheral speed, SEL, SML...), requirements regarding losses and environmental issues (noise, vibrations, ability of operating in adverse conditions).

From the results obtained, the best option came out to be the Permanent Magnet Synchronous Machine (PMSM) as it has the highest efficiency, power density and the one with the lowest mechanical losses, making it one of the most suitable for working in a wider range of high speeds.

2.3 Permanent magnets

The huge growth of permanent magnet machines (PMM) goes hand in hand with new discoveries within the magnetic materials. The materials that we know as permanent magnets are those that have a high and long-lasting magnetic energy storage capacity, being these materials used in electric machines.

The first PMM appeared in 1973, despite the precedent DC machines that existed around the XIX century that used remanent magnetism. These new types of machines appeared as a result of the discovery of new alloys, such as Al-Ni-Co; but its use was really limited to small machines, as it didn't have a very strong magnetization.

It was not until the 70s that permanent magnet machines started to evolve into bigger machines, with the discovery of new magnetic materials called the rare-earth elements. In 1980, a new alloy Nd-Fe-B, with new magnetic properties was developed. With this new finding, investigations continued, allowing to reduce prices, and consequently, extending the scope of application. [30]

2.3.1 Specific aspects

Permanent magnets are materials that, without naturally presenting a magnetic field, when magnetized can generate their own magnetic field. The fundamental difference with a conventional magnet, is that the PMM only generate field while the external force that causes it is acting.

Like ferromagnetic materials, they are characterized by their hysteresis curve. The hysteresis curve of a material is the curve that defines its magnetization, facing magnetic field (H) and magnetic induction (B); it is particular to each material. One of the properties of permanent magnets is that their hysteresis curve is especially wide. [31]

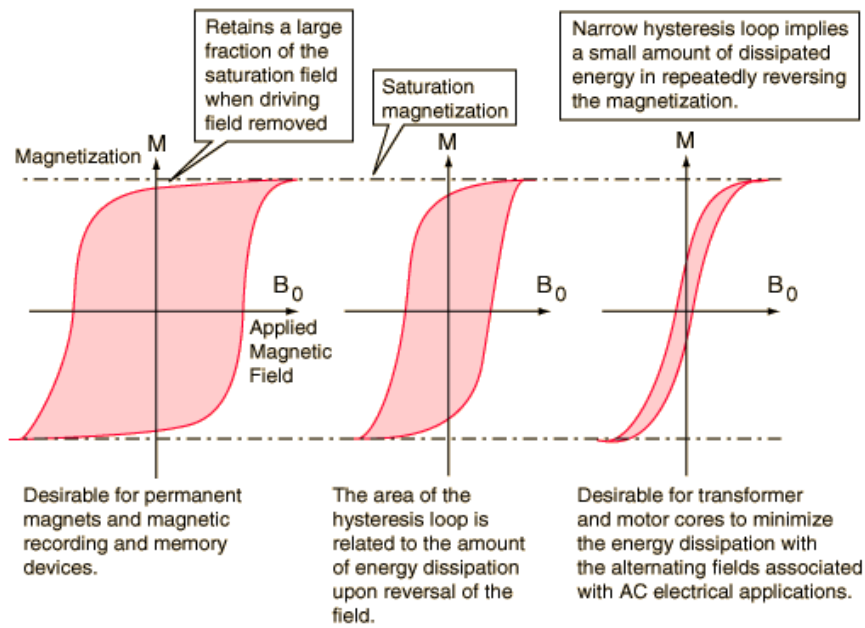
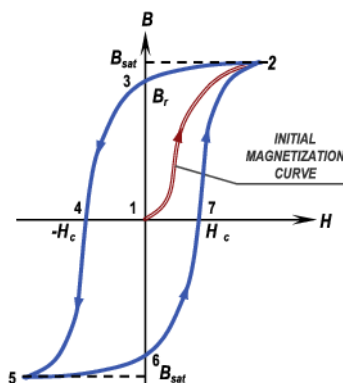

Figure 9: Hysteresis curves of different magnetic materials. Source: Hyper Physics [39]

The so-called "virgin material curve" represents what could be said to be the first magnetization of the material. When the magnetic field, H , decreases, the magnetization curve (blue) moves towards the starting position. Due to the energy storage capacity of the material, when the external field is cancelled, a relatively high level of induction is maintained in the material, called remanent induction, B_r . This effect is what is known as magnetic hysteresis, the high value of the remanent induction is what turns the material into a permanent magnet. The remanent induction represents the maximum magnetic flux intensity that can be generated by the magnet. [32]



Note: B = magnetic moment or magnetization;
 H = magnetic field; B_{sat} = saturation magnetization;
 H_c = coercivity; 1,2,3,4,5,6,7 = magnetic domain structure.

Figure 10: Hysteresis loop of ferromagnetic material. Source: [48]

Similarly, when the induction is insignificant, it can be observed that there is a magnetic field value, the so-called coercive magnetic field, H_c . This field represents the external field strength that is necessary to cancel the magnetic induction in the material. The magnitude of this variable is usually found in kA/m.

With these materials there is the disadvantage that, once demagnetized, the induction level reached is always lower than the previous ones, being an irreversible situation. Therefore, care must be taken with this type of material since, due to temperature, vibrations, etc., the phenomenon of demagnetization of the magnet could occur.

A magnet quality meter is the maximum energy product, $(BH)_{max}$, which indicates the maximum energy per unit volume that the permanent magnet can contain and therefore generate.

2.3.2 PM Synchronous Generator types

- Permanent magnet synchronous generator (PMSG)

The wound rotor synchronous generator (WRSNG) could only work under the 10.000 rpm and presented several problems, the two main ones where: the balancing within the movable parts and the electric losses. The current reached the rotor through the contact of two rings and brushes, this was the main source of loss in this kind of machines. The use of permanent magnets prevents the usage of sliding contacts which improves efficiency and simplicity. Indistinctly where these magnets are positioned, on the rotor's surface (exterior magnets) or inside of the rotor (interior magnets), the magnetic behaviour of the machine is conditioned. [33]

The most common magnets used in high-speed PMSG are composed of neodymium, iron and boron with magnetic properties that decrease when increasing temperature, making them very sensitive to corrosion, so a metal coating should be provided.

Within the high-speed PMSG a bipolar configuration is a basic requirement, and the best solution is to design one with a reduced number of slots (even with no slots) and with exterior magnets. One of the main advantages of the PMSG is that it has a high-power density, but the drawback is mounting of the magnets to the rotor that's why a retaining socket is used to keep the magnets in place.

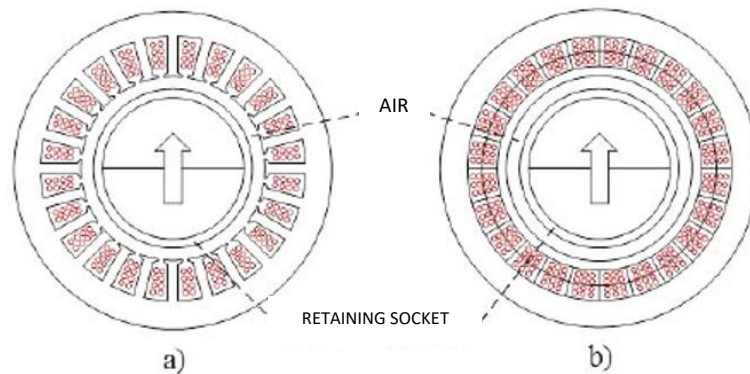

Figure 11: PMSG cross section: a) with slot; b) no slots

- Inductor alternator (IA)

The IA started to be developed at the end of the XIX century, mainly taking part in electromagnetic converters for the generation of electricity with high frequencies. Throughout the XX century its use was limited mainly to applications which required high frequencies (1.000 and 10.000 Hz). [34]

The main advantages of using an IA lie in having a no-slot rotor so no need of rings or brushes, it also lacks permanent magnets. They could be used with a teeth rotor with a width of 1mm and rotate with a rotational speed of about 200.000 rpm or higher, as the peripheral speed is limited only by the mechanical properties of the rotor itself. It has a low fabrication cost and it barely needs maintenance. The main disadvantage that could be found with an IA is that with equal output power, it requires bigger dimensions and so, greater mass than a PMSG. Also, the output frequency in an IA, for the same rotational speed, is greater than in the PMSG.

3 Electric aircrafts: future of aviation and commercial flights

In the aviation industry there is a strong interest in replacing current propulsion systems with electric motors for various reasons, but mainly for pollution issues due to the emissions of large quantities of CO₂ and NO_x, in addition to noise pollution. Aircraft consume kerosene in large quantities. Approximately, twice or three times as much CO₂ is emitted per passenger on each flight as would be consumed in a car of that calibre.

Thanks to evolution in battery technology and charging systems, electric power on commercial flights will be a future trend. With the awakening of the automated systems and the electric cars, some of the main oil producing countries like Norway or Saudi Arabia are already changing their investment strategies for future flights.

The International Civil Aviation Organization (ICAO) estimates that, by 2050, aircraft emissions could triple in volume. In addition, according to the European Commission, about 4% of global greenhouse gas emissions belong to aircrafts. Governments recognize the dangers of this phenomenon, which is why the innovation and awareness of electric airplanes is so important. This type of aircrafts has been in the skies since 1970's, but it has never been given the importance it had until today.

In 1986, Burt Rutan made the world's first non-stop, fuel-less flight, but it wasn't until 2008 that the electric motor vehicle experienced a re-emergence caused by falling prices. Now, in 2019, this technology is again being imposed with the goal of saving about 1.4 billion gallons of fuel and reducing CO₂ emissions.

For this reason, many aviation companies and start-ups began to develop new technologies in order to meet the objectives.

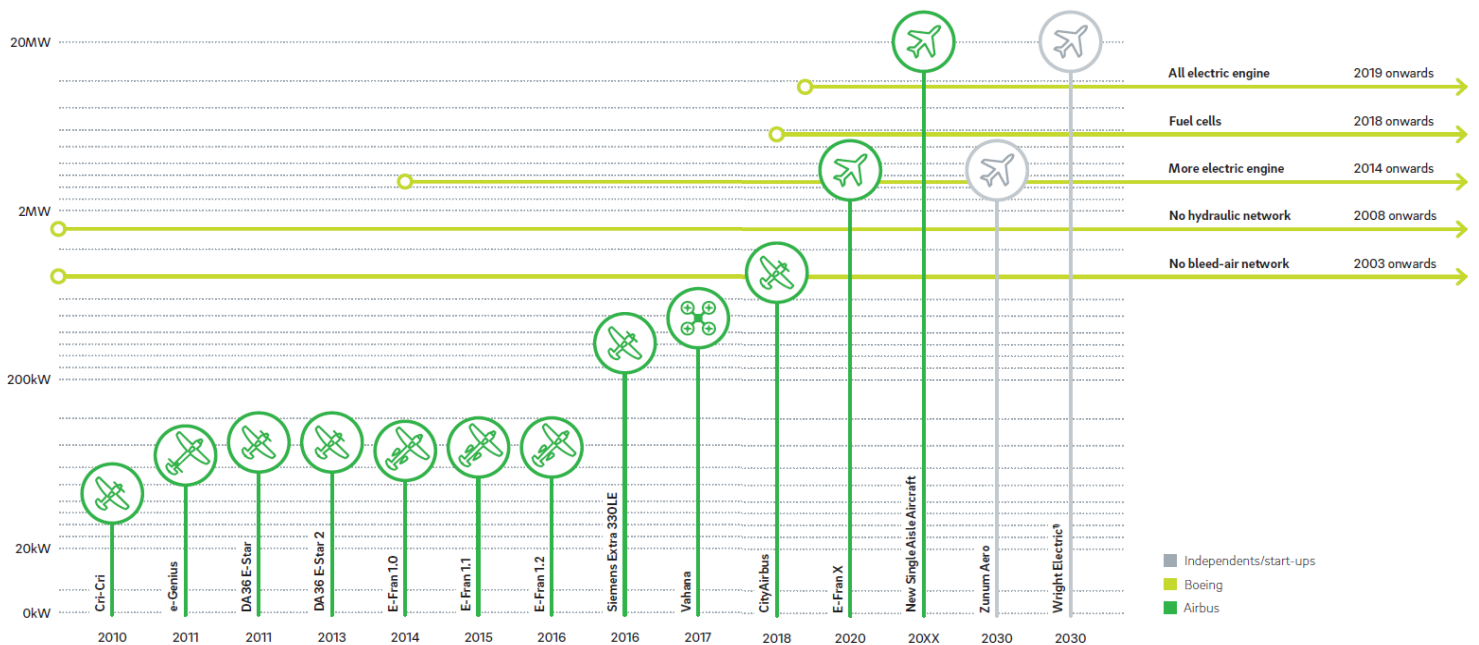

Figure 12: Evolution in time of electrical power generating. Source: Roland Berger estimate [50]

The biggest investor in this kind of technology is Airbus. As we can observe in Figure 12, the evolution of this kind of technology starts in 2010 with the *Colomban Cri-Cri*, it followed with the development of the *E-Fan* family and the *Siemens Extra 330LE* (2014-2016). On a future horizon, we can start talking about the *Eviation Alice* and *de E-Fan X*, two models that are starting to evolve in the right direction, to a more commercial aircraft design.

One of the keys for launching this type of projects is the advantages that have towards the consumers. The new aircrafts offer cheaper tickets, less noise and a higher

climb rate. With electric engines, these airplanes can maintain performance at higher altitudes where air resistance is lower, unlike combustion engines that operate less efficiently at these altitudes. Generally speaking, the aircraft's engine would require less power in order to generate an equivalent speed.

ADVANTAGES

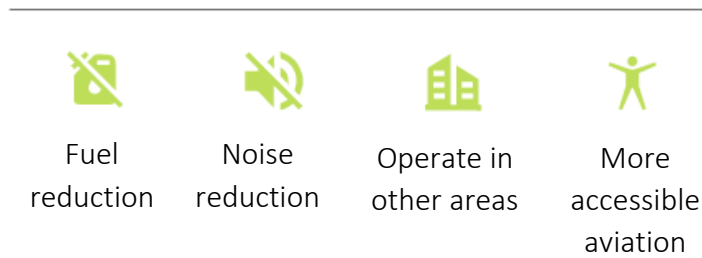

3.1 Colombian Cri-Cri

The all-electric Cri-Cri was developed by EADS Innovation Works, Aero Composite Saintonge and the Green Cri-Cri Association, making its official flight in 2010 at Le Bourget airport (Paris). The Cri-Cri was the first all-electric aerobatic plane. [35]

With all these new technical advances, the Cri-Cri aircraft has a performance of:

- 30 min autonomous cruise flight (110km/h)
- 15 min autonomous aerobatics (250 km/h)
- Clime rate of 5.3 m/sec
- Motor: REG 30 BLDC

PROPULSION SYSTEM – Motor REG 30 BLDC	
Turns	4
Output power (M _{TOP}) - P _{cont}	5-10 kW
N _{max}	6000 rpm
Voltage - U _{zk}	45-55 V
rpm/V ratio	133



Figure 13: Colombian Cri-Cri

(Aircraft data: Rotex electric [36])

3.2 E-Fan 1.0

E-fan program started in 2014, with the E-Fan 1.0, as a bet for efficiency and simplicity where technology is trying to make the flight more intuitive. This project was aimed, primarily, at training pilots. With this initiative, flying schools wanted to train their students in the new generation of aircrafts that would later fly in the commercial airlines. Some demonstrations with the aircraft were done in the Air Show Le Bourget, in Paris. It was planned to continue with the E-Fan family with future models such as the 2.0 (2017) and 4.0 (2019) but Airbus dropped the projects in favor of E-Fan X. [37]

E-Fan 1.0 – AIRCRAFT DATA	
Power plant	2 x 30kW (electric motor)
Propellers	2 x eight-blade ducted fan
Thrust	1.5 kN
Wingspan	9.5 m
Height	2 m
Length	6.67 m
Take-off weight (MTOW)	550 kg
Capacity	2
Batteries	Lithium-ion 18650, with Total of 29kWh
Battery density/cel	207 Wh/kg
Battery weight	167 kg

E-Fan 1.0 – PERFORMANCE	
Max. Speed (aprox)	220 km/h
Cruising speed	160 km/h
Endurance	45min – 1h
Lift-to-drag	16:1

(Aircraft data: Hispaviación [37])



Figure 14: Airbus E-Fan 1.0. Source: Airbus

3.3 Siemens Extra 330LE

The Extra 330LE is a completely silent acrobatic aircraft equipped with an electric motor developed by Siemens engineers. This new electric motor has a weight of 50 kg, capable of delivering 260 kW. The development of this new engine contributes to the reduction of CO₂ emissions by up to 50% in aircrafts using a hybrid propulsion system.

Extra 330LE – AIRCRAFT DATA	
Wingspan	8 m
Height	2.6 m
Length	7.5 m
Wing area	10.84 m ²
Take-off weight (MTOW)	1000 kg
Capacity	2
Batteries	28 x high-power Li-Ion batteries (18.6kWh each)



Figure 15: Motor SP260D. Source: Siemens

PROPULSION SYSTEM – Motor SP260D	
Direct Drive Brushless Permanent Magnet	
Weight (incl. prop bearing)	50 kg
Output power (MTO) - P_{cont}	260 kW
Torque - M_{cont}	1000 Nm
N_{max}	2500 rpm
Voltage - U_{zk}	580 VDC
Efficiency – η_{motor}	Max. 95%
Power density	5,2 kW/kg
Oil cooled @	90°C



Figure 16: Siemens propeller

Performance:

Max altitude of 3000m in 4min 22s at 11,5m/s

(world record, 2016)

Top speed: 337,5km/h (3km)

(Aircraft data: Siemens eAircraft [38])



Figure 17: Extra 330LE

There has been an improvement to the SP260D, breaking the previous torque density ever acquired. This new motor is the SP200D, based on the SP260 technology, with a 50% increase in torque/mass ratio. This new technology is still being tested but will allow slower rotating propellers, resulting in less noise.

	SP 260D (2015)	SP 200D (2017)
Continuous Power	260 kW	204 kW
Rotational Speed	2500 rpm	1300 rpm
Continuous torque	1000 Nm	1500 Nm
Mass	50 kg	49 kg
Torque to mass ratio	20 Nm/kg	30.6 Nm/kg

3.4 Eviation Alice

'Alice' is a 100% electric aircraft, 90% made of carbon fiber and with an electric flight control system. This nine-passenger aircraft, in addition to the pilot and the co-pilot, has a range of 1000 km and a cruising speed of 450 km/h. It is a particularly environmentally friendly aircraft, as it operates exclusively on electricity (no hybrid combinations), which will also reduce operating costs by up to 70% compared to a conventional aircraft of similar capacity. Its design is somewhat different from the usual, with a flatter fuselage than the conventional aircrafts and a smaller size. [39]

Eviation Alice – AIRCRAFT DATA	
Power plant	3 x 260 kW
Wingspan	16.12 m
Length	12.2 m
Take-off weight (MTOW)	6350 kg
Capacity	9+2
Energy pack	Li-Ion batteries – 900 kWh

Eviation Alice – PERFORMANCE	
Max. Speed (aprox)	630 km/h
Cruising speed	482 km/h
Cruise altitude	3000 km
Service ceiling	9100 m
Range + IFR reserve	1046 km
Approach speed	185 km/h

(Aircraft data: Eviation [40])



Figure 18: Eviation Alice at the Air Show Le Bourget, Paris

4 Future projects

All the previous aircrafts studied have something very similar in common; they all are small aircraft design for training pilots or to just start putting into practice the new electric motors. If we take one more step further, and we think bigger, the new electrified engines could be introduced into the actual commercial aircraft's engines, substituting the combustion chamber with an electric motor. The first aircraft that wants to introduce this new technology is the E-Fan X. There exist 3 types of configurations for the future in aviation [38]:

1. Pure Electric:

Energy from battery is used in **electric motor** to turn **electric into mechanical energy** for **propeller** rotation

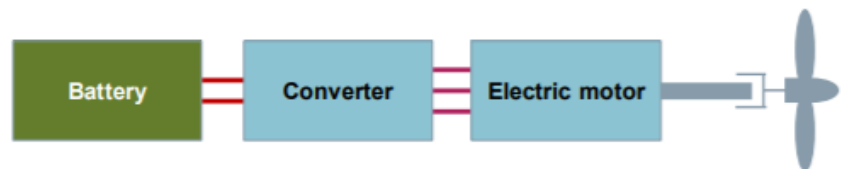

Advantage

- Full potential for distributed arrangements

Disadvantage

- Battery endurance still low

2. Serial Hybrid:

Combustion engine used to **generate electrical energy** to **charge a battery** or run the electric motor

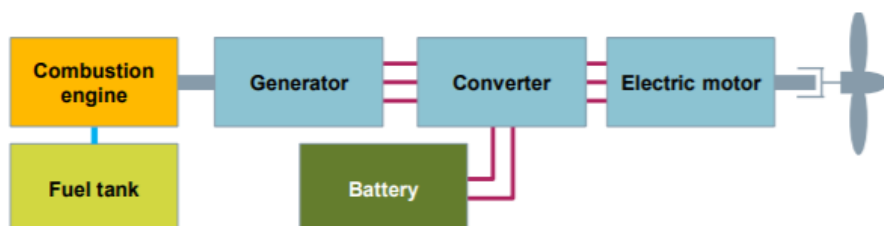

Advantage

- Separate power generation from thrust generation

Disadvantage

- Additional weight of generator
- Higher complexity than conventional

3. Parallel Hybrid:

Electric motor provides rotation and **supports** the **combustion engine** for **peak performance**

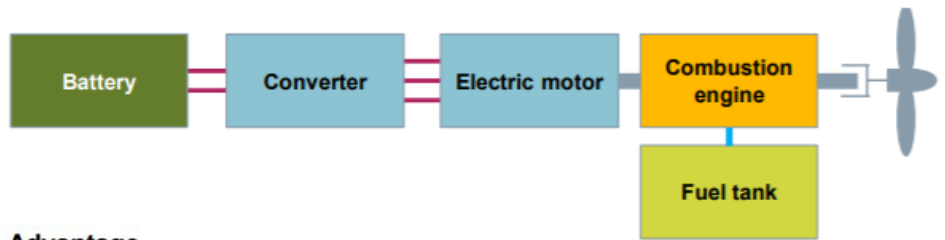

Advantage

- Conventional engine able to run at optimal power point with peak power by electric motor

Disadvantage

- Higher complexity than conventional

Basing our study on the commercial aircraft model for the E-Fan X, the British Aerospace 146, we want to model the electric motor that could be coupled to one of the four turbofans of the plane. The architecture used for this model is the serial hybrid configuration.

Firstly, we are going to describe the E-Fan X project and then we will study the take-off performance of the BAe 146. This could become a starting point for our parametric study of electric motors and generators for hybrid propulsion systems.

4.1 E-Fan X

Airbus, Siemens and Rolls-Royce are preparing the first hybrid commercial aircraft, whose propulsion system will be a combination of electric and combustion. In other words, kerosene combustion technology is mixed with electrical technology. Specifically, of the four engines that the plane assembles, one of them is totally electric, although in the future there would be two electric propulsion engines.

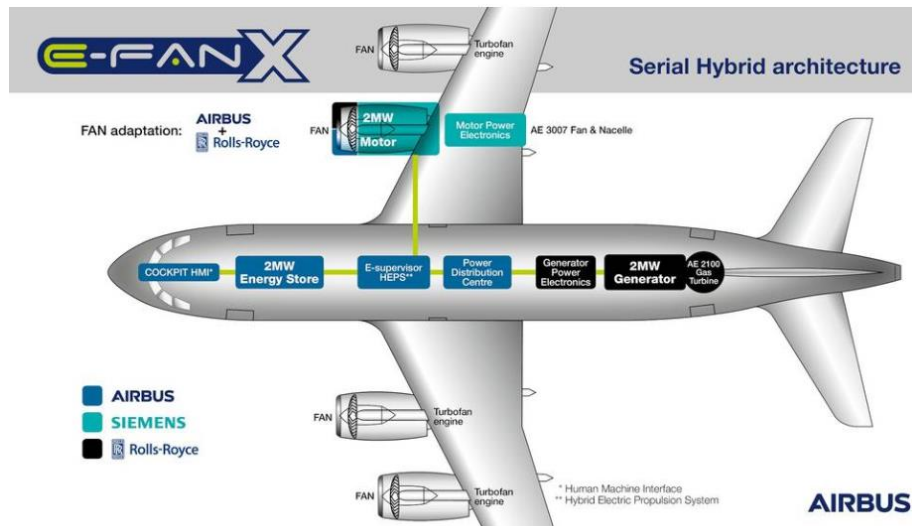

Figure 19: E-Fan X propulsion system

For this first project, an aircraft with capacity between 50 and 100 passengers was being sought for short and medium-range regional aircrafts. The model finally chosen for the development was a British Aerospace BAe 146, called E-Fan X; a four-engine aircraft with one of its conventional turbines replaced by an electric one.

The take-off and climb of the aircraft will be propelled by energy from lithium-ion batteries, which will provide 700kW (950HP) of power. Once the flight has stabilized an altitude and speed, the 2MW E-Fan X electric motor will power the aircraft for the rest of the journey, simultaneously recharging the batteries and generating power for the rest of the aircraft. [41]

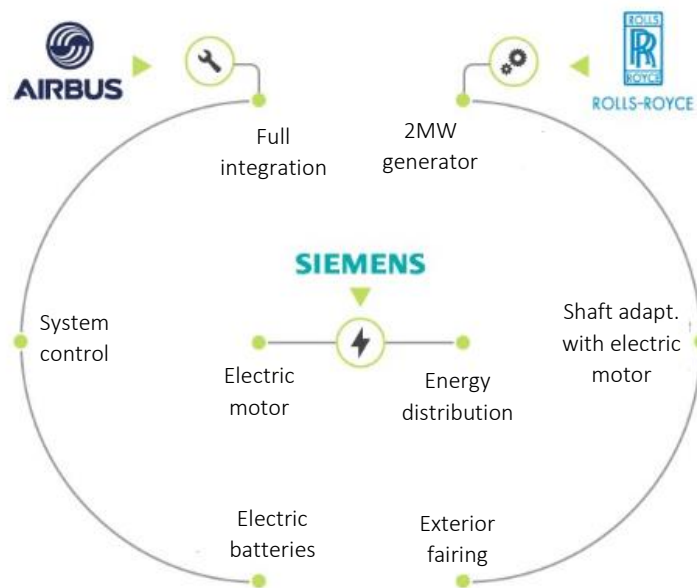

Figure 20: E-Fan X role distribution

The main challenges they will have to face are, on the one hand, those related to the weight of the aircraft, the maintenance of high speeds for long periods of time and, therefore, the development of engines with more power, but also to the reliability of these high power electrical equipment in terms of thermal and dynamic effects at high altitudes and to the electromagnetic compatibility at cruising levels.

PERFORMANCE

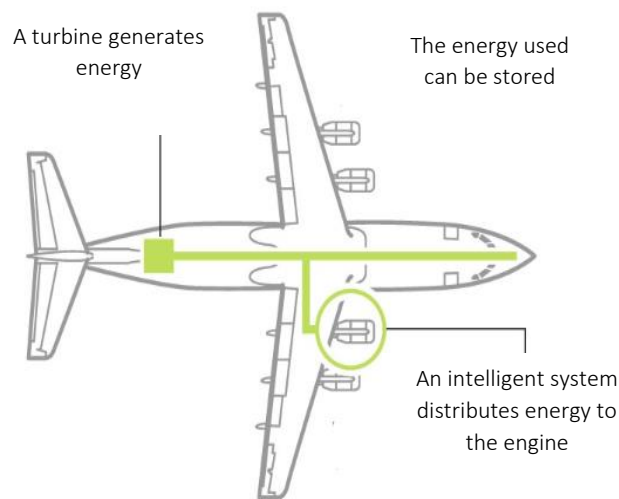

Figure 21: E-Fan X performance

MOTOR

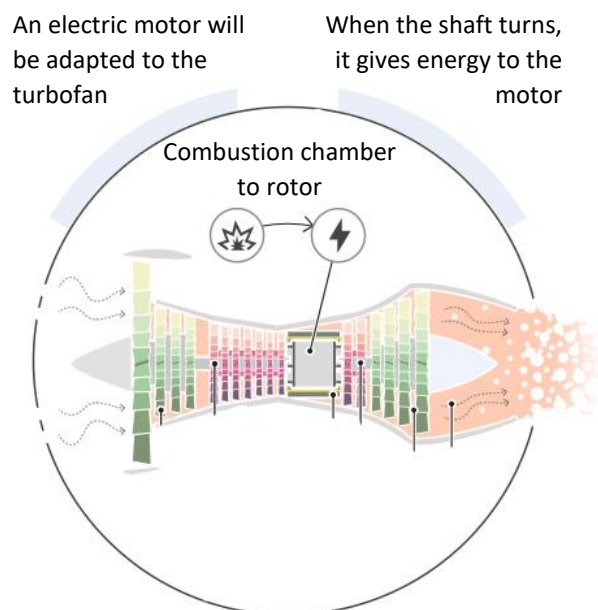

Figure 22: E-Fan X electric motor

4.2 Take-off study

In this section we will analyse the take-off and landing manoeuvres for airplanes with a tricycle train, which are the most common these days. Assuming the air to be calm, as the airworthiness standards specify for safety reasons. Take-off and landing distances will be determined presuming no wind.

For our study we are focusing on these two manoeuvres, as they are the ones that require the maximum power from the gas turbines and motors.

1. Land travel

We could say that the taking-off manoeuvre starts from the release of breaks at the head of the runway until the plane reaches the speed and height defined in the airworthiness regulations. This manoeuvre is carried out with maximum thrust, flaps in take-off position and with the landing gear out. Some of the phases are represented in the following figure:

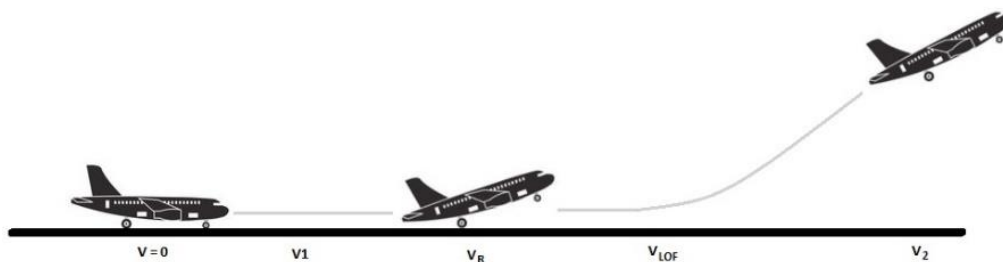

Figure 23: Taking-off phases

We are going to define the different stages:

- a) **Rolling phase** - ($0 \leq V \leq V_{LOF}$): From the moment the breaks are released until the aircraft reaches take-off speed (V_{LOF}) and stops being in contact with the floor.
 - a. Rolling with all three wheels on the floor ($0 \leq V \leq V_R$) until the rotation speed, (V_R), speed at which the nose of the aircraft lifts.
 - b. Rolling with only the principal landing gear ($V_R \leq V \leq V_{LOF}$) – the plane moves with the front nose up, until it reaches take-off speed.

- b) **Air travel phase** - ($V_{LOF} \leq V \leq V_2$): from the moment the plane is up in the air until it reaches the height of 10,7m (35 ft) and a velocity of $V_2 > 1,2V_s$
- Stall speed (V_s): minimum speed at which the plane is able to hold itself in the air, in other words, when the lift force equals the weight of the aircraft.
 - a. Curvilinear transition ($V \approx V_{LOF}$) is the moment when the plane stops touching the floor until it reaches the desire rising angle.
 - b. Rectilinear rise ($V_{LOF} \leq V \leq V_2$) occurs when the plane accelerates until reaching the desire V_2 at a height h .

The taking-off speed V_{LOF} is under the constraint that the normal force (N) in the principal landing gear is equal to zero. It is also a 10 to 20% bigger than the stall speed. This can be shown as:

$$V_S = \sqrt{\frac{2W}{\rho S C_{Lmax}}} \quad (Eq. 6)$$

$$V_{LOF} = k_1 \sqrt{\frac{2W}{\rho S C_{Lmax}}} \quad \text{with } k_1 = 1.1 - 1.2 \quad (Eq. 7)$$

The V_{LOF} is one of the most critical parameters when studying an aircraft's take-off. This velocity will be reached when the vehicle is able to rotate to an attitude to produce clime lift.

We also consider the moment when the normal force in the front landing gear is equal to zero. In this exact moment is when we reach the rotation velocity (V_R)

$$V_R \approx 0.9V_S$$

When studying the take-off, there are other characteristics that need to be taken into account. One of them is the drag coefficient that can be expressed as:

$$C_D = C_{D_0} + k \hat{C}_L^2$$

with C_{D_0} considering the high-lift devices and the landing gear; \hat{k} is the parameter that considers the ground effect that reduces the induced resistance.

Drag coefficient:

Aircraft Type	C _{do}	e
Single Engine. Light Aircraft -No Struts	0.023	0.8
Single Engine. Light Aircraft - With Struts	0.026	0.8
Multi Engine. Widebody Aircraft	0.019	0.84
Twin Engine. Widebody Aircraft	0.017	0.85
Twin Engine. Commuter Aircraft	0.021	0.85
Military Aircraft with external stores	0.028	0.70
Vintage Bi-planewith struts and bracing wire	0.038	0.70

Table 3: Nominal Drag values for several class of aircraft. Source: Aerodynamics for Students [21]

$$k = \frac{1}{\pi \times AR \times e}; \quad AR = \frac{b^2}{S}$$

$$AR = \frac{26,34^2}{77,3} = 8,975$$

$$k = \frac{1}{\pi * 8,975 * 0,84} = 0,04222$$

$$C_D = 0,019 + 0,04222 * 0,83074^2$$

$C_D = 0,0481$

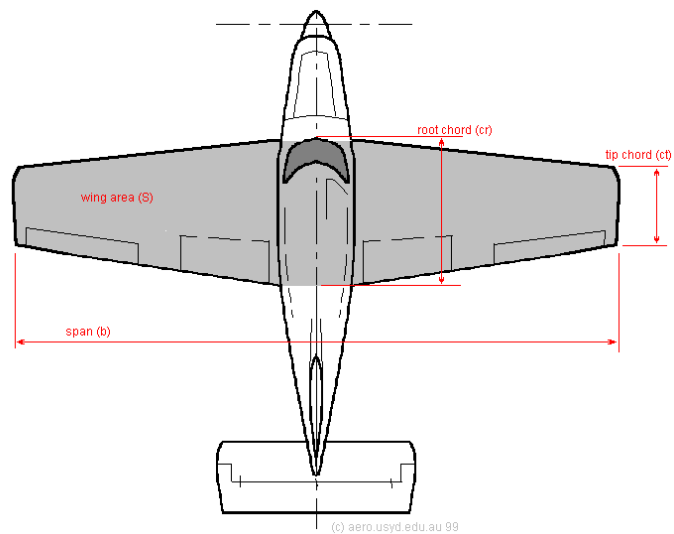

Figure 24: Aircraft's geometry. Source: google photos

When taking-off, the rotational dynamics of the plane needs to be considered. The seat angle θ satisfy the expression:

$$\theta = \gamma + \alpha$$

There are many other parameters that are considered when studying the dynamic of a flight, but we are not going to consider them in our study. This preliminary study will help us find the thrust.

Why do we need this?

When knowing the thrust needed, we can start designing the additional electric motor that will work along with the turbines.

Two key performances in the study are the take-off run (distance covered from the moment the breaks are released and the time the aircraft reaches the V_{LOF}) and the take-off distance (distance covered from the moment the breaks are released and the V_2 speed is reached at height h).

Assumptions:

- Constant weight $W=cte$;
- Horizontal runway: $\gamma = 0$ so we have $\theta = \alpha$;
- Constant acceleration along the run;
- C_L and C_D are also assumed constant;
- Thrust independent of speed.

The only values missing in our equations are the aerodynamic coefficients (C_L , C_{LMax} and C_D). These are dimensionless coefficients that are used in aerodynamic studies for analysing the forces and moments that a body undergoes while traveling through air. [42]

When focusing on an aircraft, these coefficients are established by the wing geometry, depending directly on the angle of attack, the aircraft's weight, the wing area and the wind speed (absolute and relative) [43]. With all these parameters and with help of some algorithms, we were able to find the lift coefficient (C_L and C_{LMax}). The mathematical method that we are going to use in this study comes from the German engineer Ludwig Prandtl (1875-1953). Thanks to his studies, the basis of the applied science of aeronautical engineering started to develop. His studies identified the boundary layer, thin-airfoils, and lifting-line theories.

Two modern engineers, Edgar Ruiz-Lizama and Eduardo Raffo Lecca followed Prandtl's theories and developed a MATLAB program which was able to calculate the lift coefficient for a NACA 2412 with just introducing to the system the angle of attack. [Anexo A]

As our study is focusing on the BAe 146 we tried to adjust all our parameters to the already existing aircraft. The aircraft's airfoil was found to be a 'BAe 12.2%' [44]. The percentage indicates the relative thickness, being the maximum thickness of the airfoil

expressed as a percentage of the chord itself [45]. So, with this information we can start calculating the coefficients.



Figure 25: Thickness/chord ratio. Source: Aviation Dictionary, 2014

The algorithm in MATLAB is for a NACA 2412, having a ‘thickness/chord ratio’ of 12%. [46]. With this similarity with the BAe 146’s airfoil, we could say that the values that we obtain are pretty accurate and could be used in our study.

As mentioned previously, the angle of attack is one of the most important parameters when calculating the lift coefficient. When using the algorithm from MATLAB, the only value we needed to introduce to the system was the angle at which our wing is operating. The angle of attack for the BAe 146 is always around 5.5°-6° [47] and the angle of maximum lift is around 13° approximately [48]. From these two angles we will obtain the C_L and C_{LMAX} respectively.

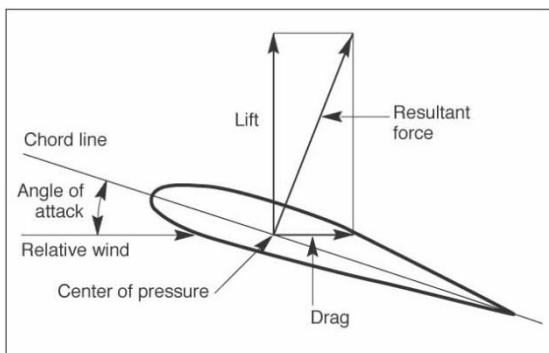

Figure 27: Wing cross-section. Source: ASA [22]

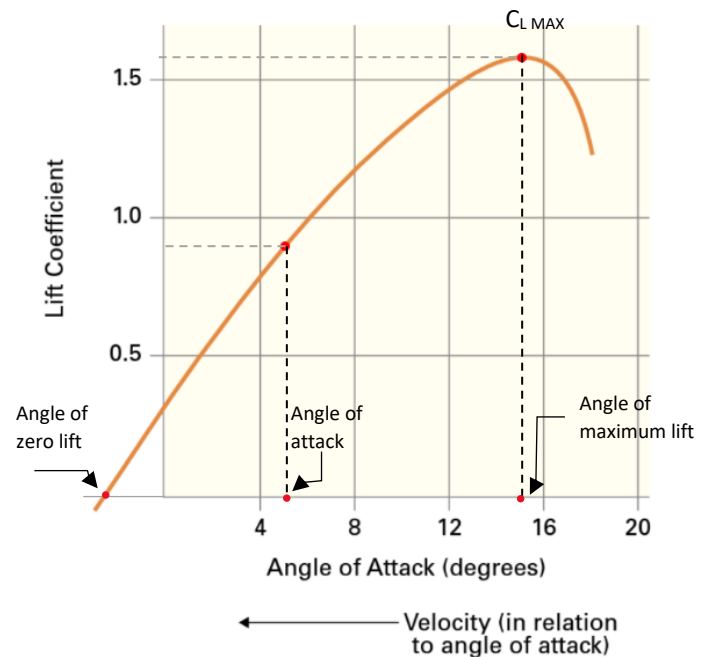

Figure 26: Graph representing our points of interest. Source: ASA [19]

When computing MATLAB we obtain:

```
Command Window
Entrada de datos :
Ingrese el angulo de ataque (sexag) -> 5.5

a =

    0.091486976413402    0.081464108880320    0.013899076386380

CL   : 0.8307566719886222
```

Angle of attack:

$\alpha = 5.5^\circ$
 $C_L = 0.830757$

```
Command Window
Entrada de datos :
Ingrese el angulo de ataque (sexag) -> 13

a =

    0.222386670312976    0.081464108880320    0.013899076386380

CL   : 1.6532237054127354
```

Angle of maximum lift:

$\alpha = 13^\circ$
 $C_{LMax} = 1.65322$

Figure 28: Lift coefficients for angles of study. Source: MATLAB

The equations of motion are:

$$\frac{dx}{dt} = V$$

$$\frac{W}{g} \frac{dV}{dt} = T - D - \mu_r (N_1 + N_2)$$

$$L + N_1 + N_2 = W$$

where μ_r is the rolling resistance coefficient (we will use a typical value of $\mu_r = 0,02$) and N_1 and N_2 are the reaction forces acting on the wheels - Figure 29.

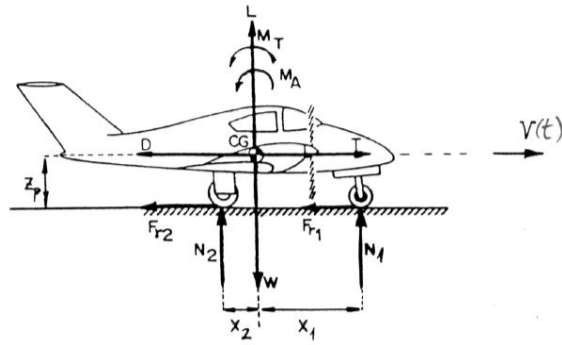

Figure 29: Free body diagram. Source: Despegue y aterrizaje

Taking V as the independent variable:

$$\frac{dx}{dV} = \frac{W}{g} \frac{V}{T - D - \mu_r(W - L)}$$

$$\frac{dt}{dV} = \frac{W}{g} \frac{1}{T - D - \mu_r(W - L)}$$

Integrating with the following Initial conditions: $x_i = 0$; $t_i = 0$; $V_i = 0$

Take-off run and time taken

As a function of the variables

$$v = \frac{V}{V_{LOF}} ; \tau = \frac{T}{W} ; s = \frac{-(C_D - \mu_r C_L)}{C_{L_{LOF}}(\tau - \mu_r)} ; C_{L_{LOF}} = \frac{2W}{\rho S V_{LOF}^2}$$

We obtain the take-off run (in meters) and the time taken (in seconds)

$$x_g = \frac{V_{LOF}^2}{g} \frac{1}{\tau - \mu_r} \int_0^1 \frac{v}{1 + sv^2} dv$$

$$t_g = \frac{V_{LOF}}{g} \frac{1}{\tau - \mu_r} \int_0^1 \frac{1}{1 + sv^2} dv$$

Now we will be using the BAe 146 aircraft information to verify the equations and see if the coefficients calculated previously are reasonable.

BAe 146

- Max take-off weight: $W = 42.185\text{kg} = 413,83\text{kN}$
- Wing area: $S = 77,3 \text{ m}^2$
- Wingspan: $b=26,34 \text{ m}$
- Thrust (sea level): $T_0 = 4 \times 31,1\text{kN} (4 \times 6990\text{lb})$
- Lift coefficient: $C_L (\alpha_s=5.5^\circ) = 0,83076$
- Nominal drag value: $C_{D0} = 0,019$
- Drag coefficient: $C_D = 0,0481$
- Max lift coefficient: $C_{L\text{Max}} (\alpha_s=13^\circ) = 1,65322$
- Friction coefficient: $\mu_r = 0,02$
- Air density at sea level: $\rho_0 = 1,225 \text{ kg/m}^3$

- Take – off run 1.509 m
- Landing run 1.103 m

$$V_{LOF} = 1.2 V_s$$

*The aerodynamic coefficients are an approximation, as these require very complex calculations that we are not studying in this project. Despite the complexity, the MATLAB program gives us a very accurate value, with which we can continue the study.

**The rest of the values are obtained from various data sheets where most of the characteristics of the aircraft are gathered. [47] [49]

- $V_{LOF} = 1,2 \sqrt{\frac{2*413834}{1,225*77,3*1,653}};$ $V_{LOF} = 79,98 \frac{m}{s}$
- $C_{L\text{LOF}} = \frac{2*413834}{1,225*77,3*79,98^2};$ $C_{L\text{LOF}} = 1,37$
- $\tau = \frac{31,1*4}{413,83};$ $\tau = 0,301$
- $s = \frac{-(0,0481-0,02*0,83076)}{1,37(0,301-0,02)};$ $s = -0,0975$

$$x_g = 1453 \text{ m}$$

$$t_g = 32,74 \text{ s}$$

With these results we can conclude that the aerodynamic coefficients that we estimated are quite accurate. We obtained a take-off run of 1453m when the official one is 1509m, confirming that the path taken is reliable. We can now continue our study with the climb and the air travel. If we are able to calculate all the times required for each moment of the take-off, we will be able to know for how long our engines will be working at maximum thrust.

2. Air travel

Now we will study the second part of the take-off

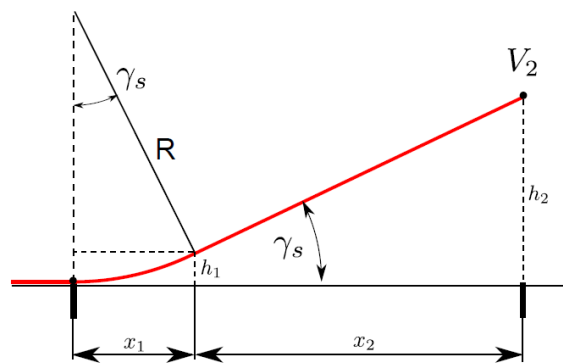

Figure 30: Curvilinear and rectilinear phases

During the transition manoeuvre, γ varies between 0 and γ_s , being the angle of rise of the aircraft, unknown.

a) Curvilinear transition:

In this part of the airplane's transition, we assume that:

- $V = V_{LOF} = \text{cte}$ and
- $\dot{\gamma} = 2 - 3 \text{ deg/s} = \text{cte}$;

$$- R = \frac{V_{LOF}}{\gamma} = cte; \quad R = 31,9 \text{ m/deg}$$

$$x_1 = R \sin \gamma_s \quad \text{Eq. 8}$$

$$h_1 = R(1 - \cos \gamma_s) \quad \text{Eq. 9}$$

$$t_1 = \frac{\gamma_s}{\gamma} \quad \text{Eq. 10}$$

b) Rectilinear rise:

In the rectilinear phase, we assume that:

- $T = cte;$
- $\gamma = \gamma_s = cte;$
- Height varies between h_1 and $h_2 = 35\text{ft} = 10,7\text{m}$ ($h_1 < h_2$)

As we are working with small angles [$\theta \sim 0$], we can approximate our solution with:

$$\text{sen}(\theta) \approx \theta$$

$$\text{cos}(\theta) \approx 1$$

$$D = \frac{1}{2} \rho V^2 S C_{D0} + k \frac{2W^2 \cos^2 \gamma_s}{\rho V^2 S} \quad \text{Eq. 11}$$

And an equation that will allow us to find the γ_s angle:

$$h_2 - h_1(\gamma_s) = \frac{W}{g} \int_{V_{LOF}}^{V_2} \frac{V \sin \gamma_s}{T - D(V, \gamma_s) - W \sin \gamma_s} dV \quad \text{Eq. 12}$$

Once we have γ_s , the horizontal distance covered by the plane during the curvilinear transition and the time taken are:

$$x_2 = \frac{h_2 - h_1(\gamma_s)}{\tan \gamma_s} \quad \text{Eq. 13}$$

$$t_2 = \frac{W}{g} \int_{V_{LOF}}^{V_2} \frac{1}{T-D(V,\gamma_s)-W \sin \gamma_s} dV \quad \text{Eq. 14}$$

At the end we just need to do the sum of each of the phases that we studied, getting the total distance travelled and the time taken during the take-off

$$x_{TO} = x_g + x_1 + x_2$$

$$t_{TO} = t_g + t_1 + t_2$$

From Eq. 12 we can obtain the angle γ_s , knowing that $h_2 = 35\text{ft}$ and $h_1 \approx 0$ (Eq. 9)

$$\gamma_s = 2,78^\circ$$

Now, knowing the only value that we were missing we can calculate the rest.

Solutions:

a) Curvilinear transition

$$x_1 = 1,55\text{m}$$

$$h_1 = 0,0375\text{m}$$

$$t_1 = 1,1\text{s}$$

b) Rectilinear rise:

$$x_2 = 218,8\text{m}$$

$$t_2 = 2,6\text{s}$$

c) Total distance and time during take-off:

$$x_{TO} = 1453 + 1,55 + 218,8$$

$$\boxed{x_{TO} = 1674\text{m}}$$

$$t_{TO} = 32,74 + 1,1 + 2,6$$

$$\boxed{t_{TO} = 36,5\text{s}}$$

Now with all the information we obtained, we can know approximately for how long our motors should be working during the take-off. During this time (t_{TO}), the electric motor should be able to work giving the required power.

4.3 Preliminary calculations

The BAe 146 has a thrust power of 124,5kN distributed between the 4 engines of the aircrafts. When substituting one of the engines with an electrified one, the thrust needs to be kept the same. For this reason, the total thrust of the engine that we will be using for this first calculations will be 31,1kN.

The first thing that we need to know is how much total thrust will be needed to generate with just the thrust of the fan, for this we will be using the NASA equations studied previously.

$$T_{fan} = T_{tot} = 31,1kN$$
$$31,1kN = 0,8 \times T_{tot \text{ FINAL}}$$

$$T_{tot \text{ FINAL}} = 38,8kN$$

The 38,8kN is the real thrust that fan will need to generate on its own with just the electric motor.

The next thing is to know how much power needs the fan to generate the required thrust. [38,8kN = 8723lb]

$$P_{fan} = 1,25 \times T_{tot \text{ FINAL}}$$
$$P_{fan} = 10\,903 \text{ HP} = 8130 \text{ kW}$$

Now that we have some of the information required to start the parametric study, we also need a range of angular speeds at which the fan and the gas turbine turns.

For the angular speed of the fan, we found that the range goes from 4.000rpm to 6.000rpm, when a gas turbine works at a speed of 50.000rpm approximately.

5 Findings and conclusions

As this project ended up being more of a research project rather than a study of my own, we found very interesting facts about the new technologies that the aviation engines are starting to develop.

Firstly, when we did the study of high-speed electrical machines and the limitations of the already existing ones, we found out that some of their principles.

- Speed is proportional to output power per unit volume
- Motor efficiency improves with speed
- Large motors have a higher specific torque and are therefore more efficient than small ones
- Motors with similar cooling systems have a rated torque almost proportional to the rotor volume (roughly the overall motor volume).

With all this said and knowing that the torque required to make an aircraft fly is disproportionately large, the already existing electric motors aren't prepared to perform in such extreme conditions.

Knowing that there already exist electric aircrafts, we continued our investigation within the pioneers in this sector. Airbus, Siemens or Eviation are among the most recognised companies in the development of electric motors for aviation purposes.

Airbus started with his E-Fan with a power plant of 30 kW but then Siemens designed his own electric motor to include it in its *Siemens Extra 330LE Aircraft*. This new motor – the SP 260D – is capable of giving 260kW of output power with a rated torque of 1000 Nm, weighting only 50 kg. With this new concept, the knowledge that we had of electric motors becomes obsolete, as now the size of the motor doesn't goes related to the rated torque it provides.

Further on, in 2017, a new version of the motor was designed, the SP 200D. This new electric motor has a weight of 49 kg, capable of delivering 204 kW, with a rated torque of 1500 Nm. Having this in mind, a new parameter was established by scientists and engineers, the torque to mass ratio. This ratio serves as a guide for these new electric motors, as what is most desired is to obtain the highest torque with the lowest mass. Between both siemens models, this ratio was increased by a 50%, as the mass was kept constant. The development of this new engines contributes to the reduction of CO₂ emissions by up to 50% in aircrafts using a hybrid propulsion system.

As it can be observed in the project, we introduce a section where we start talking about future projects related to de ones stated before. Airbus, Siemens and Rolls-Royce are preparing the first hybrid commercial aircraft, whose propulsion system will be a combination of electric and combustion. As there is not much public information about

the technology behind the 2MW electric motor that they want to be using in the aircraft, we started developing some preliminary calculations in order to have a clearer idea of the electric motor that they will be using.

I suggest that this project be continued by an engineer with a more electric profile, maybe with the help of an aeronautical engineer, due to the complexity that the project can reach. At the end we tried using the NASA equations for the replacement power per weight for actual turbines in aviation, resulting in very basic formulas.

6 Bibliography

- [1] "EASA - European Aviation Safety Agency," [Online]. Available: <https://www.easa.europa.eu/eaer/climate-change/aviation-environmental-impacts>.
- [2] J. Barba González, "Equipo Altran," Altran, 6 octubre 2016. [Online]. Available: <https://equipo.altran.es/evolucion-de-los-sistemas-del-avion-nuevos-usos-de-la-electricidad-en-la-aeronave/>.
- [3] "planete energies," Total Foundation, 14 January 2019. [Online]. Available: <https://www.planete-energies.com/en/medias/close/how-they-work-turbo-generators>.
- [4] B. Bates, R. C. Belaire and C. Hammann Stephan, "Hybrid electric propulsion system using a dual shaft turbine engine". US Patent US5762156A, 1995.
- [5] R. A. Hyde, M. Y. Ishikawa and E. K. Y. Jung, "Hybrid propulsive engine including at least one independently rotatable compressor rotor". US Patent US8596036B2, 2009.
- [6] N. Bailey Noval, "Aircraft Hybrid Engine". Spain Patent EP 2 998 557 B1, 2014.
- [7] H. Morvan, Interviewee, *Electrifying the Aviation Industry*. [Interview]. 2018.
- [8] A. H. Epstein, "Distributed Propulsion: New Opportunities for an Old Concept," Cambridge, MA, 2007.
- [9] W. J. Boyne, "aviadores - Temas de Aviación," 2005. [Online]. Available: <http://www.aviadores.eu/dornierdox.html>.
- [10] "War History Online," [Online]. Available: <https://www.warhistoryonline.com/war-articles/bv-222-wiking-seaplane.html>.
- [11] "dutchops.com," [Online]. Available: http://www.dutchops.com/AC_Data/Hughes/Hughes_H4/Hughes_H4_Hercules.htm.
- [12] J. McNeil, "EDN," 9 February 2019. [Online]. Available: <https://www.edn.com/electronics-blogs/edn-moments/4457575/Boeing-747-takes-flight--February-9--1969>.
- [13] Y. Gibbs, "NASA," NASA, 28 February 2014. [Online]. Available: <https://www.nasa.gov/centers/armstrong/news/FactSheets/FS-056-DFRC.html>.
- [14] M. S. A. Buj, "Modelado de vehículo eléctrico e híbrido paralelo," 2017.
- [15] Toyota, "Toyota," [Online]. Available: <https://toyota-latam.com/hibridos/>.
- [16] L. A. Kilgore, J. F. W. Godsey, F. B. Powers and B. A. Rose, "Electrical Airplane Propulsion". US Patent US2462201A, 1943.

- [17] "4. Improving Aircraft Performance," in *Securing the Future of U.S. Air Transportation: A System in Peril*, Washington, DC , The National Academies Press .
- [18] A. S. Gohardani, G. Doulgeris and R. Singh, "Challenges of future aircraft propulsion: A review of distributed propulsion technology and its potential application for the all electric commercial aircrafts," UK, 2010.
- [19] A. Hughes and B. Drury, "Electric Motors and Drives," Elsevier, 2013.
- [20] D. Johnson and G. V. Brown, "Power Requirements Determined for High-Power-Density Electric Motors for Electric Aircraft Propulsion," 2005. [Online]. Available: <https://ntrs.nasa.gov/search.jsp?R=20050217395>.
- [21] A. Orta and C. Astudillo, "Máquina Síncrona," Venezuela, 2015.
- [22] J. Borg Bartolo, H. Zhang, D. Gerada, L. De Lillo and C. Gerada, "High speed electrical generators, application, materials and design," IEEE, 2013.
- [23] C. Huynh, L. Zheng and D. Acharya, "Losses in High Speed Permanent Magnet Machines Used in Microturbine Applications," ASME, 2008.
- [24] A. Tuysuz, M. Steichen, C. Zwyssig and J. W. Kolar, "Advanced cooling concepts for ultra-high-speed machines," IEEE, 2015.
- [25] A. Tenconi, S. Vaschetto and A. Vigliani, "Electrical Machines for High-Speed Applications: Design Considerations and Tradeoffs," IEEE, 2014.
- [26] J. D. Ede, Z. Q. Zhu and D. Howe, "Rotor resonances of high-speed permanent-magnet brushless machines," IEEE, 2002.
- [27] R. R. Moghaddam, "High speed operation of electrical machines, a review on technology, benefits and challenges," IEEE, 2014.
- [28] D. Gerada, A. Mebarki and C. Gerada, "High-Speed Electrical Machines: Technologies, Trends, and Developments," IEEE, 2014.
- [29] F. Martínez and P. Andrada, "High-Speed Synchronous Generators," SciELO, 2017.
- [30] E. Neville Da Costa, "The Early History of the Permanent Magnet," London.
- [31] "Hyper Physics," [Online]. Available: <http://hyperphysics.phy-astr.gsu.edu/hbase/Solids/hyst.html>.
- [32] M. C. O. M. Team, "MCMA - Motion Control & Motor Association," 2016. [Online]. Available: <https://www.motioncontrolonline.org/blog-article.cfm/The-Hysteresis-Loop-Testing-Permanent-Magnet-Materials/2>.

- [33] P. Arumugam, J. Dusek, A. Aigbomian and G. Vakil, "Comparative design analysis of Permanent Magnet rotor topologies for an aircraft starter-generator," IEEE, 2014.
- [34] K. Sivasubramaniam, T. Zhang and M. Lokhandwalla, "Development of a High Speed HTS Generator for Airborne Applications," IEEE, 2009.
- [35] R. electric, "Cri-Cri Airplane Project," 2010, [Online]. Available: <http://www.rotselectric.eu/portfolio-item/cri-cri/>.
- [36] R. electric, "Rotor electric," 2010. [Online]. Available: <http://www.rotselectric.eu/products/bldc-motors/reg-series/>.
- [37] L. Martín-Crespo, "Hispanaviación," 2015. [Online]. Available: <http://www.hispaviacion.es/e-fan-el-nuevo-concepto-electrico-de-volar-segun-airbus/>.
- [38] S. AG, "Siemens eAircraft: Disrupting the way you will fly!," 2018. [Online]. Available: <https://www.ie-net.be/sites/default/files/Siemens%20eAircraft%20-%20Disrupting%20Aircraft%20Propulsion%20-%20OO%20JH%20THO%20-%2020180427.cleaned.pdf>.
- [39] "La Razón," 2019. [Online]. Available: <https://www.larazon.es/economia/llega-alice-el-primer-avion-electrico-de-la-historia-y-con-ingenieria-espanola-MP24182349>.
- [40] "Eviation Alice," [Online]. Available: <https://www.eviation.co/alice/>.
- [41] A. Ferreras, "NOVANDO," 2018. [Online]. Available: <https://innovando.larioja.com/innovacion-frontera/cielos-limpios-rapidos-20180124001051-ntvo.html>.
- [42] "Aerodynamics for Students," 1995-2019. [Online]. Available: <http://www.aerodynamics4students.com/>.
- [43] A. -. CIF, "ASA - Aviation supplies & Academics," 2016. [Online]. Available: <http://learntoflyblog.com/2016/08/11/cfi-brief-angle-of-attack-as-it-relates-to-the-lift-coefficient/>.
- [44] D. Lednicer, "The Incomplete Guide to Airfoil Usage," 2010. [Online]. Available: <https://m-selig.ae.illinois.edu/ads/aircraft.html#conventional>.
- [45] "Aviation Dictionary," 2014. [Online]. Available: http://aviation_dictionary.enacademic.com/6741/thickness_chord_ratio.
- [46] E. Ruiz-Lizama and E. Raffo Lecca, "Cálculo de los coeficientes aerodinámicos usando MATLAB[®]," 2014.
- [47] "AVRO RJ Technical Data - at a glance," 2004. [Online]. Available: http://www.angelwingsva.com/lib/DOWNLOAD/pdf/RJ_Tech_data_at_a_glance__April_2004.pdf.

- [48] "Take-off and climb," in *146-200/300 Jetliner - OPERATIONS MANUAL*, UK, Just Flight, 2012, p. 44.
- [49] "Flight Global - Archive," Flight International, 2001. [Online]. Available: <https://www.flightglobal.com/pdfarchive/view/2001/2001%20-%202963.html>.
- [50] F. Peinado, E. Medel, R. Silvestre and A. Garcia, "Open-grade wearing course of asphalt mixture containing ferrite for use as ferromagnetic pavement," Research Gate, 2013.
- [51] [Online].
- [52] R. Berger, "Evolution of electrical power generating capacity by technology," in *Aircraft Electrical Propulsion- The next chapter of aviation?*, Navigation Complexity, September, 2017, pp. 14,15.
- [53] A. Aero, 2019. [Online]. Available: <http://all-aero.com/index.php/contactus/44-planes-a-b-c/16601-airbus-e-fan>.
- [54] "4. Electric Propulsion," in *Commercial Aircraft Propulsion and Energy Systems Research: Reducing Global Carbon Emissions*, The National Academies of Science, engineering and medicine , pp. 51-70.

7 Annex I: Motor REG 30 BLDC

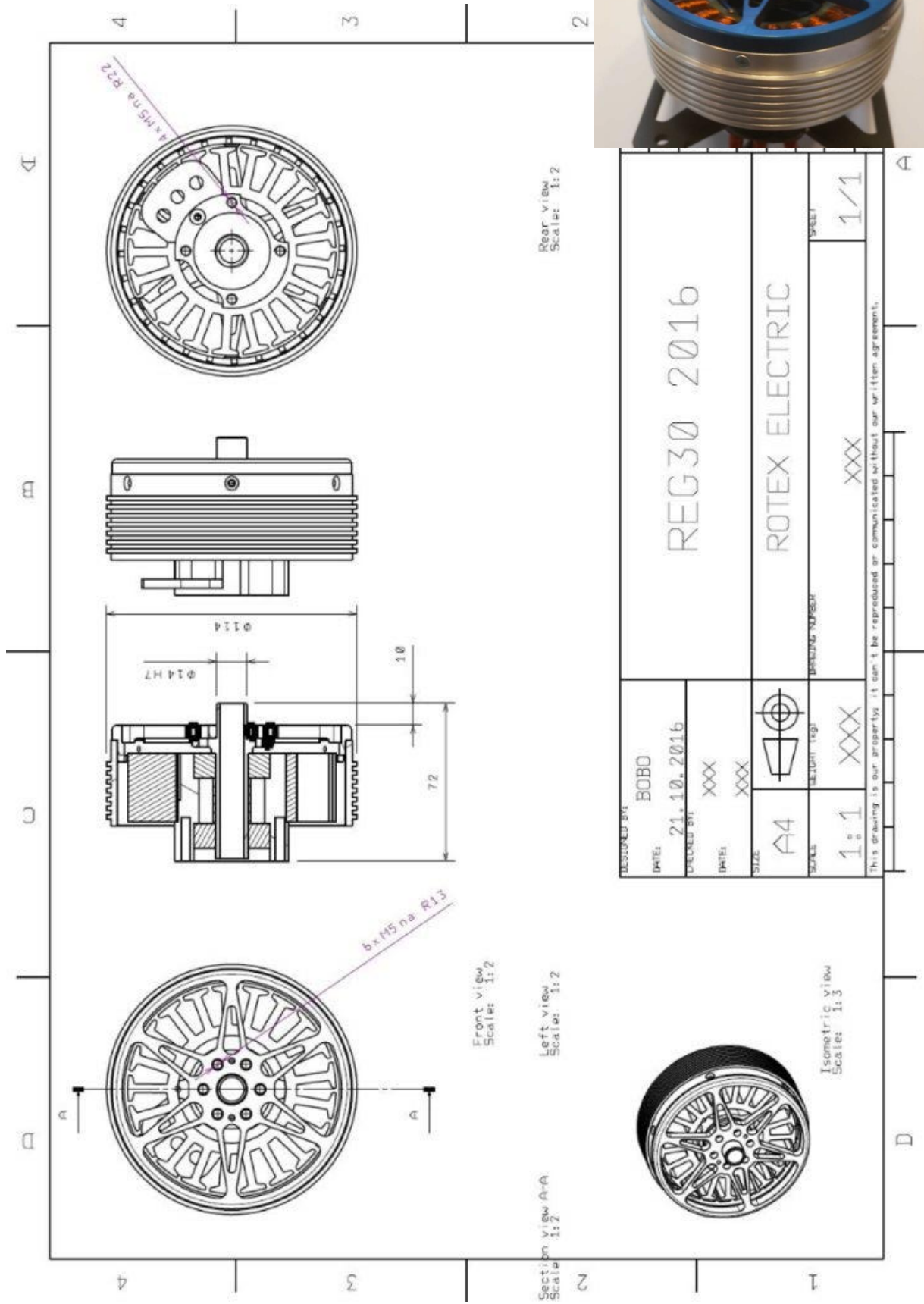

8 Annex II: MATLAB program coefficients

```
function coefSustentacion()

global n;
clc;
fprintf('Entrada de datos :\n');
attack = input('Ingrese el angulo de ataque (sexag) -> ');
%attack = 5;
alpha = attack*pi/180;

% coeficientes de a
n = 0;
area = Simpson3('naca',0,pi,20);

a(1) = alpha-area/pi;
for i = 2:3
    n = i - 1;
    area = Simpson3('naca',0,pi,20);
    a(i) = 2*area/pi;
end

% computo de cl y cm
cl = pi*(2*a(1) + a(2));

%impresion de los coeficientes de a
format long;
a
%impresion de cl
fprintf('    CL    :%20.16f\n',cl);
```

```
function p=Simpson3(f,a,b,n)

    h = (b - a)/n;
suma = 0;
x = zeros(n+1,1);
y = zeros(n+1,1);
for i = 1:n+1
    x(i) = a+h*(i-1);
    y(i) = feval(f,x(i));
end

    n = n+1;
for i = 2:n-1
    if rem(i,2) == 1
        suma = suma + 2*y(i);
    else
        suma = suma + 4*y(i);
    end
end
p = h*(y(1) + suma + y(n))/3;
```

```
function p = naca(angulo)

global n;
if angulo < 1.36944
    p = (0.125*cos(angulo) - 0.025)*cos(n*angulo);
else
    p = (0.0555*cos(angulo) - 0.0111)*cos(n*angulo);
end
```