



UNIVERSIDAD PONTIFICIA COMILLAS

ESCUELA TÉCNICA SUPERIOR DE INGENIERÍA (ICAI)

OFFICIAL MASTER'S DEGREE IN THE ELECTRIC POWER INDUSTRY

Master's Thesis

DISTRIBUTION NETWORK ARCHETYPES FOR SIMULATING FLEXIBILITY PROVIDED BY DISTRIBUTED ENERGY RESOURCES

Author: Diego García Cuenca
+34 636356244; email: diegogarciacuenca@gmail.com

Supervisor: Tomás Gómez San Román
+34 915406220; email: tomas.gomez@iit.comillas.edu

Cosupervisor: Carlos Mateo Domingo
+34 91 542-280; email: carlos.mateo@iit.comillas.edu

Master's Thesis Presentation Authorization

THE STUDENT:

Diego García Cuenca

..... 

THE SUPERVISOR

Tomás Gomez San Román

Signed:  Date: 8 / 7 / 2019

THE CO-SUPERVISOR

Carlos Mateo Domingo

Signed:  Date: 8 / 7 / 2019

Authorization of the Master's Thesis Coordinator

Dr. Luis Olmos Camacho

Signed: Date: / /

AUTHORIZATION FOR DIGITALIZATION, STORAGE AND DISSEMINATION IN THE NETWORK OF END-OF-DEGREE PROJECTS, MASTER PROJECTS, DISSERTATIONS OR BACHILLERATO REPORTS

1. Declaration of authorship and accreditation thereof.

The author Mr. /Ms. Diego García Cuenca

HEREBY DECLARES that he/she owns the intellectual property rights regarding the piece of work: **DISTRIBUTION NETWORK ARCHETYPES FOR SIMULATING FLEXIBILITY PROVIDED BY DISTRIBUTED ENERGY RESOURCES**

that this is an original piece of work, and that he/she holds the status of author, in the sense granted by the Intellectual Property Law.

2. Subject matter and purpose of this assignment.

With the aim of disseminating the aforementioned piece of work as widely as possible using the University's Institutional Repository the author hereby **GRANTS** Comillas Pontifical University, on a royalty-free and non-exclusive basis, for the maximum legal term and with universal scope, the digitization, archiving, reproduction, distribution and public communication rights, including the right to make it electronically available, as described in the Intellectual Property Law. Transformation rights are assigned solely for the purposes described in a) of the following section.

3. Transfer and access terms

Without prejudice to the ownership of the work, which remains with its author, the transfer of rights covered by this license enables:

- a) Transform it in order to adapt it to any technology suitable for sharing it online, as well as including metadata to register the piece of work and include "watermarks" or any other security or protection system.
- b) Reproduce it in any digital medium in order to be included on an electronic database, including the right to reproduce and store the work on servers for the purposes of guaranteeing its security, maintaining it and preserving its format.
- c) Communicate it, by default, by means of an institutional open archive, which has open and cost-free online access.
- d) Any other way of access (restricted, embargoed, closed) shall be explicitly requested and requires that good cause be demonstrated.
- e) Assign these pieces of work a Creative Commons license by default.
- f) Assign these pieces of work a HANDLE (*persistent* URL). by default.

4. Copyright.

The author, as the owner of a piece of work, has the right to:

- a) Have his/her name clearly identified by the University as the author
- b) Communicate and publish the work in the version assigned and in other subsequent versions using any medium.
- c) Request that the work be withdrawn from the repository for just cause.
- d) Receive reliable communication of any claims third parties may make in relation to the work and, in particular, any claims relating to its intellectual property rights.

5. Duties of the author.

The author agrees to:

- a) Guarantee that the commitment undertaken by means of this official document does not infringe any third party rights, regardless of whether they relate to industrial or intellectual property or any

- other type.
- b) Guarantee that the content of the work does not infringe any third party honor, privacy or image rights.
 - c) Take responsibility for all claims and liability, including compensation for any damages, which may be brought against the University by third parties who believe that their rights and interests have been infringed by the assignment.
 - d) Take responsibility in the event that the institutions are found guilty of a rights infringement regarding the work subject to assignment.

6. Institutional Repository purposes and functioning.

The work shall be made available to the users so that they may use it in a fair and respectful way with regards to the copyright, according to the allowances given in the relevant legislation, and for study or research purposes, or any other legal use. With this aim in mind, the University undertakes the following duties and reserves the following powers:

- a) The University shall inform the archive users of the permitted uses; however, it shall not guarantee or take any responsibility for any other subsequent ways the work may be used by users, which are non-compliant with the legislation in force. Any subsequent use, beyond private copying, shall require the source to be cited and authorship to be recognized, as well as the guarantee not to use it to gain commercial profit or carry out any derivative works.
- b) The University shall not review the content of the works, which shall at all times fall under the exclusive responsibility of the author and it shall not be obligated to take part in lawsuits on behalf of the author in the event of any infringement of intellectual property rights deriving from storing and archiving the works. The author hereby waives any claim against the University due to any way the users may use the works that is not in keeping with the legislation in force.
- c) The University shall adopt the necessary measures to safeguard the work in the future.
- d) The University reserves the right to withdraw the work, after notifying the author, in sufficiently justified cases, or in the event of third party claims.

Madrid, on 7th.. ofJuly....., ...2019..

HEREBY ACCEPTS

Signed 

Reasons for requesting the restricted, closed or embargoed access to the work in the Institution's Repository

According to my supervisors, this master thesis should not be published or available to everyone without our expressed permission.



UNIVERSIDAD PONTIFICIA COMILLAS

ESCUELA TÉCNICA SUPERIOR DE INGENIERÍA (ICAI)

OFFICIAL MASTER'S DEGREE IN THE ELECTRIC POWER INDUSTRY

Master's Thesis

DISTRIBUTION NETWORK ARCHETYPES FOR SIMULATING FLEXIBILITY PROVIDED BY DISTRIBUTED ENERGY RESOURCES

Author: Diego García Cuenca
+34 636356244; email: diegogarciacuenca@gmail.com

Supervisor: Tomás Gómez San Román
+34 915406220; email: tomas.gomez@iit.comillas.edu

Cosupervisor: Carlos Mateo Domingo
+34 91 542-280; email: carlos.mateo@iit.comillas.edu

ABSTRACT:

This master thesis studies and analyses the operation of distribution networks under different flexibility options such as demand response (load shifting, load shedding...) or distributed generation.

To shed light on this topic and be able to present justified conclusions, the studies will be based upon a mathematical model developed by Tractebel and programmed in an optimization software (GAMS).

The novelty of the programme is that it is extremely scalable and in a disaggregated way can give information about grid's behaviour under different scenarios. The input data to feed the model has been provided by the IIT.

Once the model is programmed, some tests will be done to be sure that the obtained outputs are trustful and then various sensibility analyses about different parameters will be performed to acquire the maximum information as possible about distribution network operation.

Furthermore, this master thesis also identifies the main limitations of the model and gives some possible ideas to enhance the model. For example, a programme to include electrical storage in the code will be included in this mentioned section.

INDEX OF CONTENTS

1.	INTRODUCTION.....	5
1.1	EVOLUTION OF THE ELECTRIC SECTOR: DISTRIBUTION NETWORKS	5
1.2	MOTIVATION	9
1.3	OBJECTIVES	10
1.4	METHODOLOGY.....	11
1.5	WORK PLAN.....	12
2.	DISTRIBUTION NETWORKS	14
2.1	DISTRIBUTION NETWORKS IN EUROPE.....	14
2.2	CHALLENGES OF DISTRIBUTION NETWORKS	16
3.	PROBLEM PRESENTATION AND RESOLUTION	19
3.1	MATHEMATICAL MODELLING OF THE CORE MODEL	20
	OBJECTIVE FUNCTION:	20
	TIME-WINDOW OPTIMIZATION:.....	21
	GENERAL DESCRIPTION OF THE NETWORK AND ASSUMPTIONS:	21
	ASSUMPTIONS AND PRE-REQUISITES FOR THE MODEL.....	23
3.2	CODING OF THE CORE MODEL IN GAMS	24
	SETS:	24
	PARAMETERS:	25
	VARIABLES:	26
	EQUATIONS:.....	28
4.	ANALYSIS OF THE SCENARIOS AND RESULTS.....	37
4.1	CHEKING THE FEASIBILITY OF THE MODEL	37
	SCENARIO 1: LOW DEMAND	39
	SCENARIO 2: MEDIUM DEMAND	41
	SCENARIO 3: HIGH DEMAND	43
4.2	CALCULATION OF THE COST WEIGHTS IN THE OBJECTIVE FUNCTION	46
4.3	SIMULATION OF FLEXIBILITY OPTIONS & ANALYSIS OF THE RESULTS.....	47
	DEMAND INCREASE SIMULATION:.....	47
	SENSITIVITY ANALYSIS AROUND THE ASSOCIATED COST OF THE LOSSES AND LOAD SHEDDING:.....	51
	DISTRIBUTED GENERATION INCREASE IN THE MV/LV SUBSTATIONS.....	52

***DISTRIBUTION NETWORK ARCHETYPES FOR SIMULATING FLEXIBILITY PROVIDED BY
DISTRIBUTED ENERGY RESOURCES***

SENSITIVITY ANALYSIS TRIGGERING FLEXIBILITY OPTIONS:.....	54
5. LIMITATIONS AND POSSIBLE IMPROVEMENTS OF THE MODEL	59
5.1 ELECTRICAL STORAGE	59
5.2 TIME-DEPENDANT PRICE	62
5.3 LOCATIONAL DISTURBANCE.....	63
6. CONCLUSIONS.....	64
7. REFERENCES.....	66

1. INTRODUCTION

The European electric power sector has undergone important changes and evolutions due to the unbundling of the electric sector. After the unbundling, new modifications have arisen in response to the three key objectives set by the European Union (EU) within its energy policy in ‘The third energy package’: environmental sustainability, security of supply and competitiveness [1]. The actual energy package, ‘The Clean energy for all Europeans’ have entered play in this same year (2019) with even more ambitious objectives than the previous package so an evolution in the electric sector is expected in the following years.

This first introductory of this project section will explain the main characteristics and issues of the object of study of this master thesis, electric distribution networks. The introduction will also comprise the motivation, objectives and methodology of the thesis, where the relevance of the problem will be explained and why and how to solve it will be described.

1.1 EVOLUTION OF THE ELECTRIC SECTOR: DISTRIBUTION NETWORKS

A new paradigm appeared when the electric sector shifted from utilities regulated as vertically integrated monopolies that controlled all the value-chain of the power industry (generation, transmission, distribution and retail) to a liberalised unbundled scenario where many different companies own the different parts of the business. Distribution and Transmission, as network-based natural monopolies remained regulated. Despite their obvious physical similarities, with related components such as power lines, substations, transformers, etc. Transmission and distribution grids fulfil different purposes. The transmission grid connects large and geographically scattered production centres to demand hubs, generally located near cities and industrial areas, maintaining the electric power system fully interconnected and in synchronous operation. [2] The transmission lines operate at very high voltages, being the backbone of the electric power system, interconnecting all its hubs and acting as a market facilitator. On the other hand, we find the distribution grid. This lower voltage networks branch off the transmission grid to carry electric power to the final consumers. The distribution grid operates in different voltage levels, ranging from 132 kV (high voltages) to 0.4 kV (end consumers low

DISTRIBUTION NETWORK ARCHETYPES FOR SIMULATING FLEXIBILITY PROVIDED BY DISTRIBUTED ENERGY RESOURCES

voltages) depending on the country. The structure of the distribution network may vary depending on the area of supply, but its operation is always radial. [4]. In the urban areas the grid usually runs in the underground with a meshed structure that increases the redundancy and reliability level of the network. In rural areas, distribution networks have a radial structure and are formed by typically overhead lines, therefore, the reliability is lower than in urban areas.

The next figures show the typical grid structure of a distribution grid in an urban area and in a rural area.

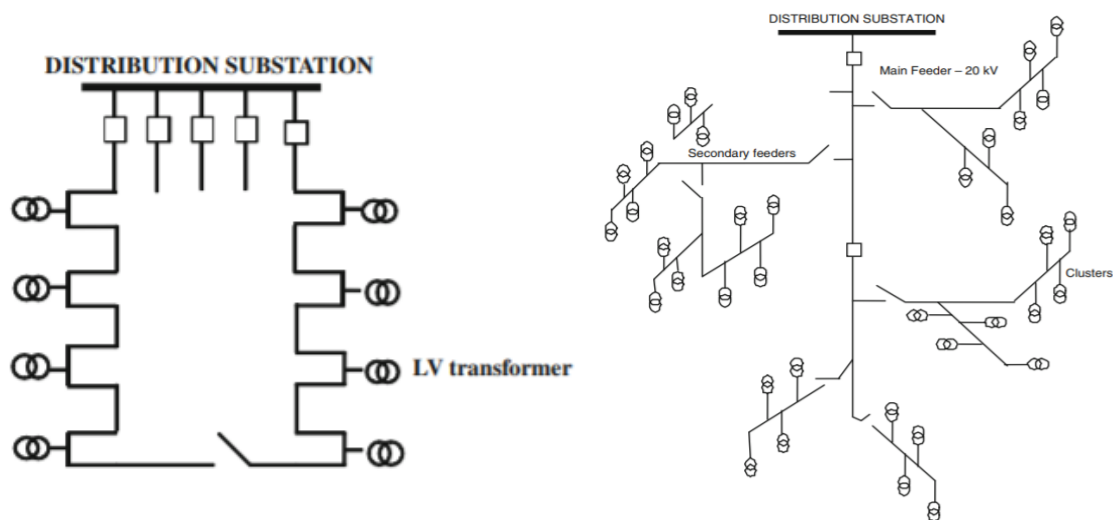

Figure 1. Grid structure of an urban area and a rural area.

Regarding the ownership of these networks we find that in most countries there is one national transmission grid, with, as a rule, one or few owners, while a larger number of operators distribute electrical power in different areas of the country [2]. There are more than 2000 distributor operators in Europe [3], nonetheless, the number of distributors with more than 100.000 customers is below 200. With around 190 DSOs covering the 95% of the European electric demand. These figures imply that there is a great diversity of distribution grids and distribution system operators (DSOs), however, there is a lack of consolidated and shared knowledge of their techno-economic features. This insufficiency of information prevents distribution grids of evolving towards a more efficient system based on low-carbon technologies and distributed energy resources.

The distribution sector has been considerably affected by the technological and regulatory changes of the last years. There has been a sharp increase of small and medium generation systems placed close to end consumers and connected directly to the distribution grid. These

DISTRIBUTION NETWORK ARCHETYPES FOR SIMULATING FLEXIBILITY PROVIDED BY DISTRIBUTED ENERGY RESOURCES

generators typically based on renewable sources are called distributed generation (DG). Distributed generation, thanks to its decentralised nature and low environmental impact has the potential to foster the achievement of the EU energy policy objectives [5]. The believed benefits of DG are enormous, it increases the security of supply, the efficiency of the system, generates new market opportunities and reduces the dependency on fossil fuels, however, there are numerous technical issues that have to be addressed in order to allow a higher penetrations level of DG in the distribution grids. The main concern is whether the grids built many years ago are prepared for this sudden change. Apart from technical barriers, a major important aspect towards achieving the desired level of DG penetration is a successful unbundling of DSOs (Distributed system operators). The unbundling is an important requirement to allow fair and non-discriminatory network and market access for new DG players. [6]. The principal act of the EU regarding unbundling is the Directive 2009/72/EC [7], which is part of the Third Package. This Directive regulates the process of unbundling. There are different possibilities of unbundling, the functional unbundling is the simplest one and consists on setting independent organisation. The minimum requirement for distribution companies is the legal and functional unbundling. This unbundling requires a more complete separation of the former vertical integrated utility. Finally, there is the ownership unbundling where different operators and owners controls the whole system, this is the example of the Netherlands, nonetheless, in most countries the unbundling model adopted is the legal and functional. A correct and complete unbundling will create a transparent market environment for all the stakeholders and will remove the abuse of integrated utilities that, at the same time, produces energy and operates the grid.

To conclude, this subsection will end up analysing the new challenges the distribution sector is facing in the latter years. The main current task for distribution networks is the transformation to smarter grids. Smart grids are based on an enhanced monitoring and control of the grid allowing a more flexible behaviour to the grid users, both, consumers and producers. Smart grids will facilitate an efficient integration of DG based on renewable sources, combined with smart metering will enable demand side response and new tariff systems, the grid will become a market facilitator for new stakeholders, and it will also accelerate the deployment of electric vehicles.

The next figure shows how an active smart distribution grid can reduce considerable the required investment costs to connect different levels of penetration of DG. Similar figures can be obtained regarding electric vehicle (EV) penetration.

DISTRIBUTION NETWORK ARCHETYPES FOR SIMULATING FLEXIBILITY PROVIDED BY DISTRIBUTED ENERGY RESOURCES

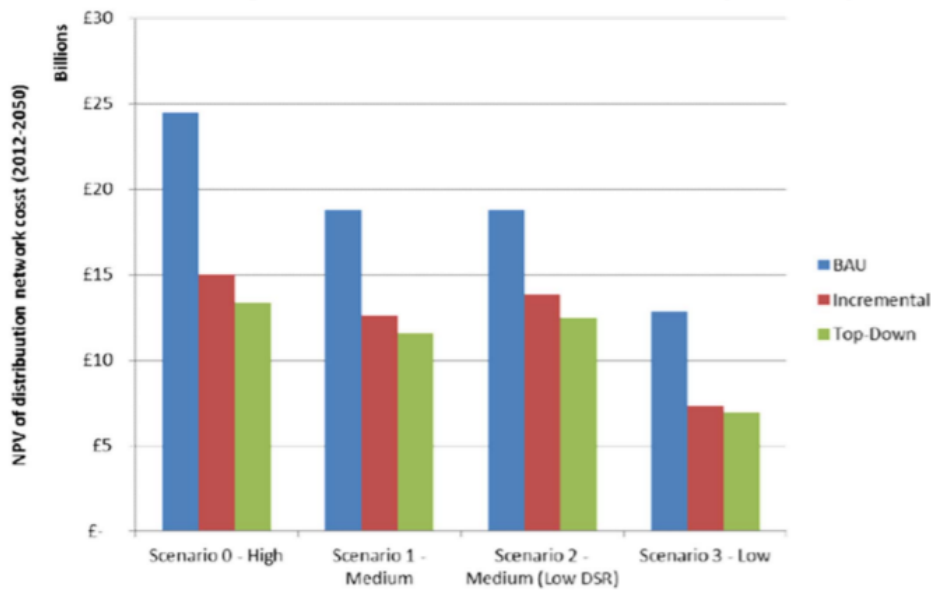

Figure 2. Network investment required for connecting different penetration levels of DG

Source: EA Technology, 2012

Distribution networks arise as a key asset to enable the transition to an environmentally sustainable energy sector with the increasing penetration of DG. They are also crucial for the decarbonization of the transport, with the escalating deployment of the EV, finally, distribution grids are vital for the implementation of the new figures of the prosumer and the energy aggregator.

The outcome that these changes will have in the distribution business is uncertain and difficult to predict due to the diverse distribution network models that exist and the large amount of information that DSOs in Europe manage. An interesting line to deal with this uncertainty is to try to represent in a general and broad way the distribution networks and the all the possible flexibility solutions in different scenarios.

This master thesis will try to shed light on the future of distribution networks and how the upcoming challenges may affect the business. A mathematical model will be programmed in an optimizing software to represent in a simpler way all the distribution grids and their operation under certain relevant circumstances. The next subsection of this work contains more information about the importance and motivation of this thesis.

1.2 MOTIVATION

As it has been seen, distribution networks are facing numerous challenges and suffering many changes due to economical, technological and regulatory reasons. These uncertainties provided to the fact that there are thousands of DSOs in Europe with millions of kilometres of wires creates several inefficiencies as the information flow is intricate, limited and opaque. The mathematical models that can accurately represent distribution grids are very complex and difficult to build and usually represent only a small portion of the whole grid.

These issues are a barrier that prevents from a better understanding and prediction of how the distribution grids may behave under certain scenarios, for example, under a specific level of DG penetration. This master thesis will use a Distribution Core Model created by TRACTEBEL to better represent the electricity networks and their interactions with other flexibility solutions. The main benefit of this innovative Core model is that in a more streamlined and disaggregated way than other models, sheds light on the operation of the grids and can be easily applied to different regions or countries thanks to its simplicity. Another use of the Core model is the possibility of analysing different scenarios such as demand flexibility, DG penetration, or EV deployment which are hot topics nowadays for the DSOs.

This master thesis is important because the solutions obtained in this project will give a more complete picture of the operation of distribution systems under certain scenarios and will help in improving decision-making processes. (For example, market design or investment decision planning). This thesis is also important since the results developed may also help DSOs in managing the grid and these new challenges in accordance with minimum standards of quality of supply.

1.3 OBJECTIVES

The key objectives of this master thesis are the followings:

- Coding of the Core Model using General Algebraic Modelling System (GAMS). So that a mathematical model represents accurately and in a disaggregated way the distribution grid of many regions.
- Gather the required data and information to feed the parameters of the model.
- Shed light on the operation of distribution grids under different flexibility scenarios.
- Study how different levels of integration of EV or DG may affect the operation of the distribution grid.
- Study and compare the differences of the obtained results between the core model and a traditional optimal dispatch flow model.
- Help DSOs in the management of the grids and guide them in the decision-making process.

1.4 METHODOLOGY

Probably the key and most challenging task of the master thesis is getting the Core Model to work in GAMS. This assignment requires certain expertise with the programming language. To acquire the desired level of proficiency to perform this task an intensive study of the programming language and of different GAMS examples will be performed. When coding the Core Model, a bottom-up methodology will be chosen. The coding will start with a simpler approach including less conditions and equations and adding little by little the remaining parts of the model.

Once the model is programmed, the first idea is to check the feasibility and trustfulness of the obtained results, first by checking the mathematical coherence of the equations and then by testing the value of the output for some hypothesis.

Then simulations and sensibilities analysis will be performed to study the behaviour of the distribution grid under certain circumstances. The main parameters and input data that will be modified in each scenario are going to be the demand, the associated cost of activating each option and the physical parameters of the grid.

The main sources of data regarding both, quantitative and qualitative data of the distribution grids will be the "Distribution system operators observatory, 2016", the "Regulation of the Power Sector, Perez-Arriaga (essentially chapters 1 and 5)", the "Eurelectric report, 2013" and several engineering papers that will be mentioned in the references part.

1.5 WORK PLAN

The main tasks to perform and their estimated time of duration is shown in the Gantt diagram below, elaborated during the definition of the project scope in January.

During the elaboration of the thesis weekly meetings will be scheduled with the tutors to revise the development of the project.

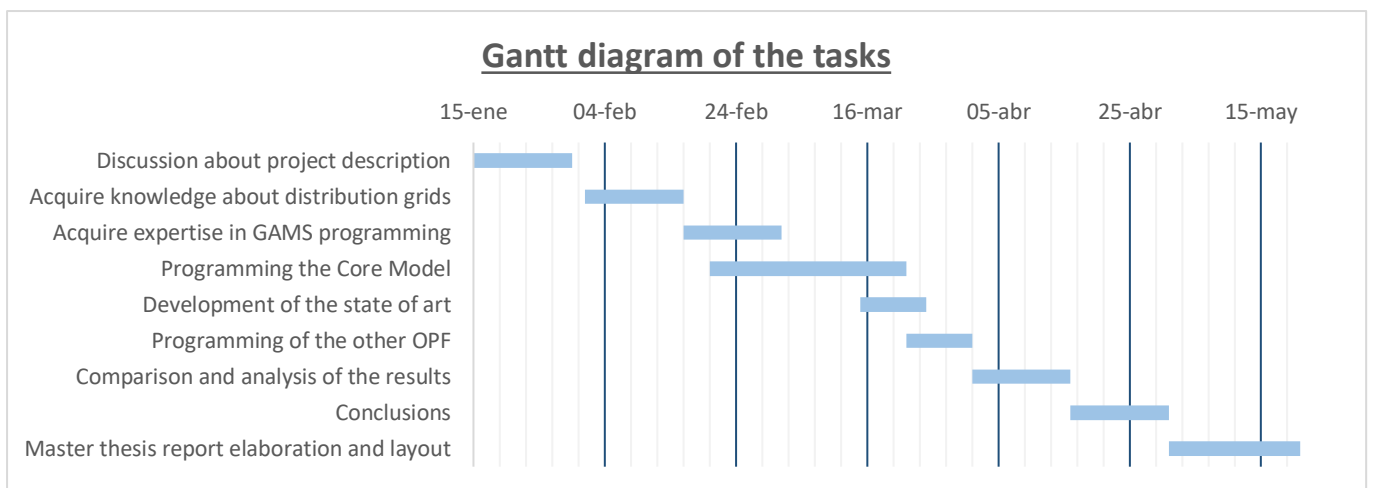

Figure 3. Gantt chart

The “discussion about project description” task consisted on defining the scope during the first weeks.

The next tasks, “Acquire knowledge about distribution grids” and “Acquire expertise in GAMS programming” are based on reading and studying textbooks and papers about distribution grids and practicing GAMS programming with different examples found on the website.

The “Development of the state of art” will entail the first two sections of the master thesis, as presented in the table of contents of page 8.

“Programming of the other OPF” will require the software design of a classical OPF that solves a similar problem than the Core Model.

The last three tasks; “Comparison and analysis of the results”, “Conclusions” and “Master thesis report elaboration and layout” will involve the final parts of the thesis, gathering the results, comparing them, writing the conclusions and finishing the final report.

**DISTRIBUTION NETWORK ARCHETYPES FOR SIMULATING FLEXIBILITY PROVIDED BY
DISTRIBUTED ENERGY RESOURCES**

Next figure will show a Gantt diagram of the real time spent in the elaboration of the master thesis, so that the reader can compare both diagrams and see the changes that have occurred during the elaboration of the master thesis.

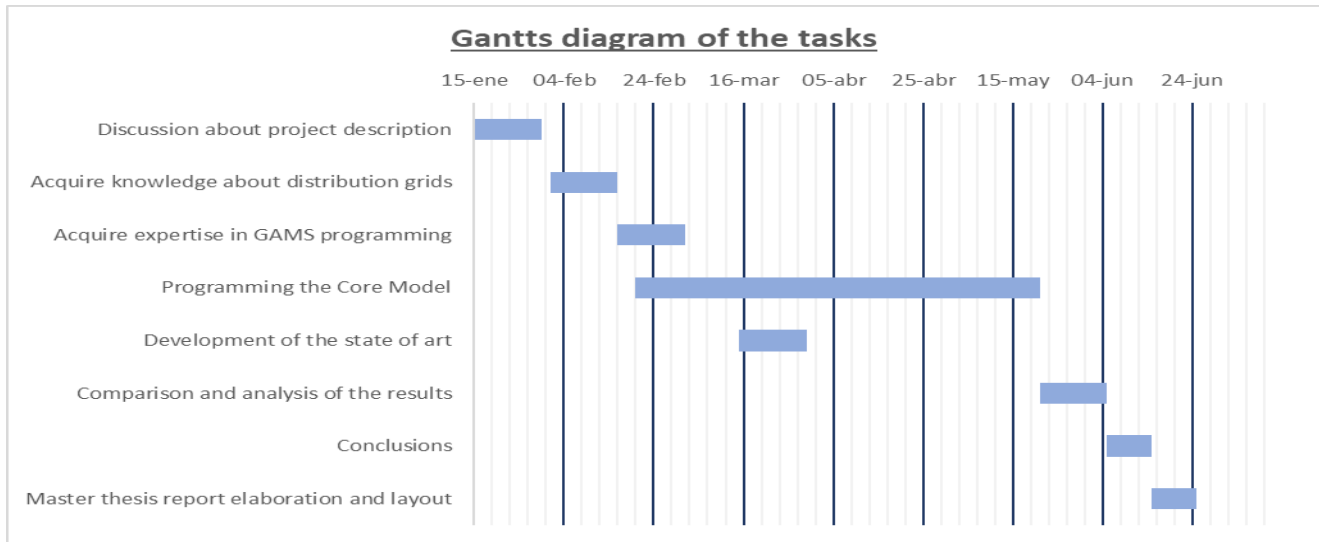

Figure 4. Gantt chart.

2. DISTRIBUTION NETWORKS

This chapter of the thesis will provide a detailed analysis of distribution networks. Upcoming challenges for the distribution business will also be explained in the section 2.2.

As mentioned previously, many changes in the power industry have affected all the supply-chain actors, and until recently, almost all the debate and investigation has focused on the generation and transmission activities [6]. However, the latter trends have brought distribution to the centre stage, emerging as a key actor to enhance the rapid deployment of all the innovative distributed and flexible solutions. This new paradigm is expected to change the distribution activity that we have always known, creating new opportunities as well as challenges to the reliability and operation of the system. In order to decide the most efficient grid model for the upcoming encounters, a detailed technical and economical knowledge of the network and their operation is needed. There is a lack of the needed information and the little information available is, in general, not shared by the DSOs as they consider their information an important commercial asset.

The next section will focus on the distribution business in Europe, remarking some important figures that will help in understanding this cloudiness in the information flows.

2.1 DISTRIBUTION NETWORKS IN EUROPE

There are two main reasons that prevent a full understanding of the distribution networks in Europe. The first one, as we have mentioned before, is due to the confidential nature of much of this information, as it can have an important commercial value. Second, there are a huge quantity of different electric distribution systems in Europe. According to a recent Eurelectric report, there are 2,400 DSOs in Europe, supplying 2,700 TWh of energy every year to 260 million customers, through more than 10 million kilometres of lines. The figures are striking, and each country, due to many different reasons, has a different distribution model. While some countries have one single DSO, others have hundreds of them. There are also differences between the countries related to the level of unbundling, the voltage operation and other technical concerns. This heterogeneity is the other main reason that complicates the understanding of this activity.

DISTRIBUTION NETWORK ARCHETYPES FOR SIMULATING FLEXIBILITY PROVIDED BY DISTRIBUTED ENERGY RESOURCES

Electricity distribution business, as a natural monopoly, is a fully regulated business, where their allowed revenues is determined by the national regulatory authority of each country. Regarding the required level of unbundling of DSOs, the European Union states in the Third Energy Package that all the distribution companies that are part of a vertically integrated utility (VIU) have to comply with an accounting, functional and legal separation from the parent company. It is remarkable the fact that in some countries, DSOs serving less than 100.000 customers can be excused from the requirements of functional and legal unbundling.

The next figure shows the approximate number of DSOs in Europe, also it remarks the number of DSOs that serve less than 100.000 customers, which is much lower.

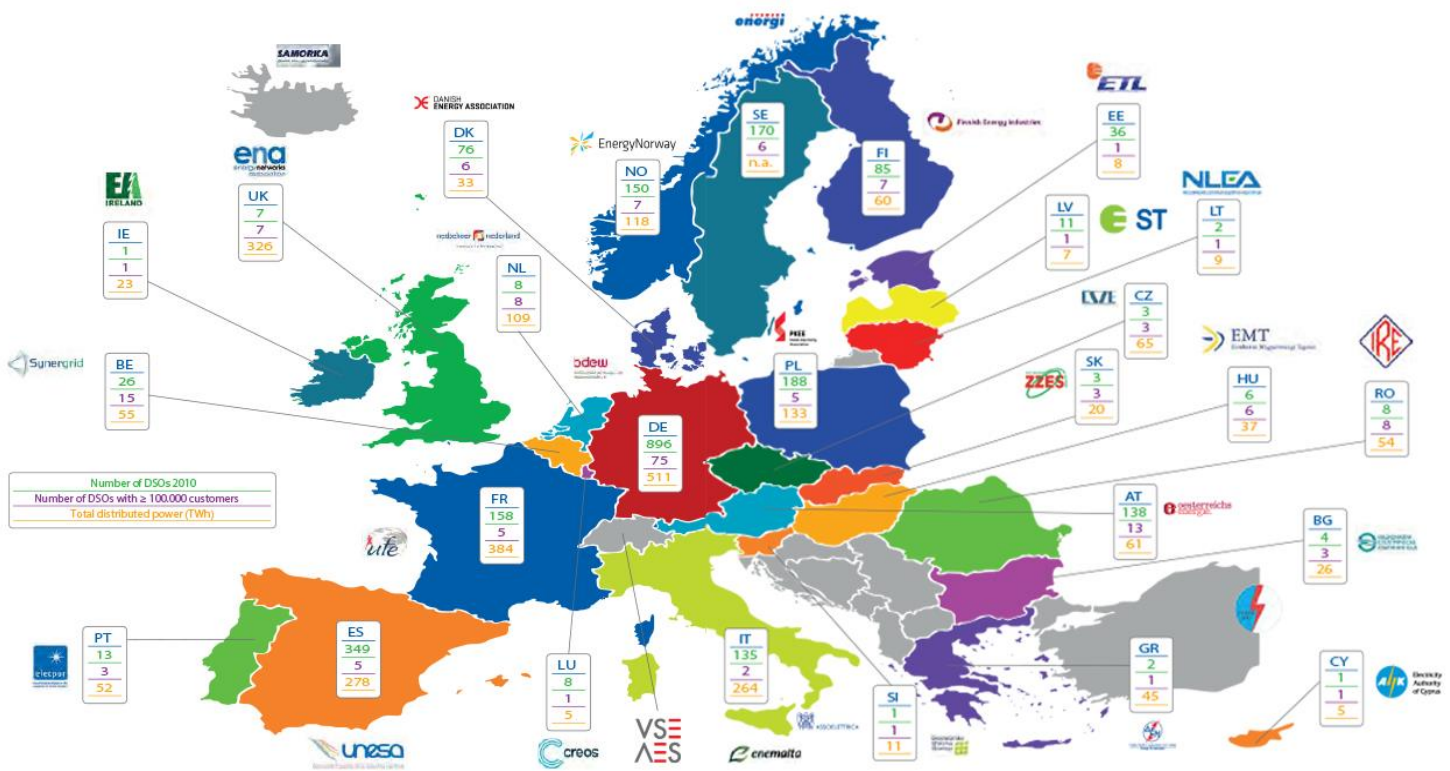

Figure 5. Number of DSOs in Europe.

Source: Eurelectric

From figure 4, it can be concluded that for almost every country, despite having hundreds of distribution companies only few of them serve the vast majority of the demand. This is mainly caused by historical and political reasons, where many DSOs are in charge of supplying small areas granted by concessions.

DISTRIBUTION NETWORK ARCHETYPES FOR SIMULATING FLEXIBILITY PROVIDED BY DISTRIBUTED ENERGY RESOURCES

The next figure shows the different ownership models used in Europe. Again, there is a great heterogeneity.

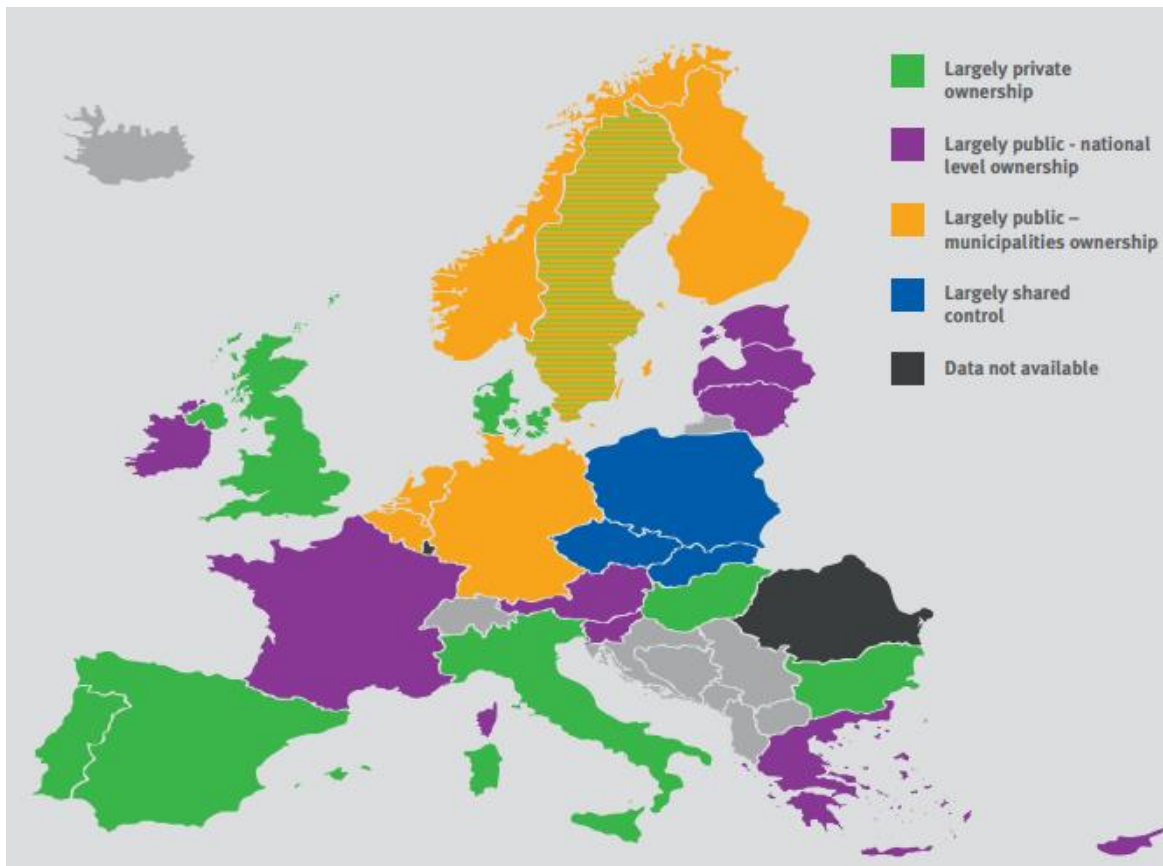

Figure 6. DSO ownership in Europe.

Source: Eurelectric

2.2 CHALLENGES OF DISTRIBUTION NETWORKS

Nowadays, distribution companies' function goes beyond just supplying electricity and are supposed to become system operators and market facilitators. As system operators, DSOs must secure a reliable electricity flow to the customers while managing and investing in a distribution system that changes rapidly giving more importance to new flexible loads and distributed generation. As market facilitators, DSOs are required to provide non-discriminatory access to their networks, and the new decentralised model will make this an extremely important point to provide efficient signals for all agents to participate in the market. DSOs will also have to manage metering infrastructure and act as information hubs.

DISTRIBUTION NETWORK ARCHETYPES FOR SIMULATING FLEXIBILITY PROVIDED BY DISTRIBUTED ENERGY RESOURCES

The evolution towards smart distribution systems is creating a series of challenges to DSOs that will be analysed in this present section.

First, the electrification of the transport, despite only being a small part of the total electricity demand, it can have a big impact on the load if all the drivers plug-in their vehicles at the same time during peak hours, this may create the necessity of reinforcing the network. However, this issue can be easily mitigated with the introduction of smart charging strategies that can allocate the load of the vehicle in different hours where the price of the energy is cheaper, this would be a win-win situation where the customer charges its vehicle cheaply meanwhile the DSO avoids the cost of reinforcing the grid. At the end smart charging strategies are a kind of active load management or demand responsiveness.

Other issue that will strain the distribution network is the renewable distributed energy resources, these intermittent generators will require DSOs to balance demand and supply in real time. The required level of investment and monitoring of this grid architecture is so high that some residential communities are choosing to migrate to off-grid microgrids solutions with a connection to the main grid in case of a backup emergency. One example of this is California, where there are more than 30 microgrids accounting for the 40% of the residential PV installed in the whole US. The proliferation of DER apart from challenges, also creates opportunities, for example, emerging technologies such as batteries have a lot of synergies with intermittent generation and will benefit from the deployment of DER.

DSOs play a main role in the energy transition as the efficient integration of renewables and the effective electrification of the transport depends enormously of the distribution network and the distribution monitoring. In addition, the issues that this evolution towards smart grids generates can be alleviated with flexibility solutions, that if are controlled by the DSO at local level can help to improve the efficiency of the operation and avoid unnecessary grid reinforcements. The European Commission, in the Clean Energy for all Europeans indicates that a framework for the cooperation between transmission and distribution is strongly needed, furthermore, a market-based mechanism must be created to procure the appropriate use of flexibility services from DSOs.

The DSOs need to be prepared for a transition that has already started, upgrading monitoring and control systems and introducing new business models. This master thesis will try to, through a mathematical simulation model, obtain valuable results about how different flexibility

***DISTRIBUTION NETWORK ARCHETYPES FOR SIMULATING FLEXIBILITY PROVIDED BY
DISTRIBUTED ENERGY RESOURCES***

solutions may impact the operation of real distribution networks, so that DSOs and policymakers can have certain knowledge and be prepared to hit in the decision-making process.

3. PROBLEM PRESENTATION AND RESOLUTION

This section of the project will contain the presentation of the problem and the steps followed to try to solve it following a precise methodology.

Presence of Distributed energy resources (DERs) like PV, storage and electric vehicles are features of the modern European distribution network. Even though DERs help in decarbonisation, their intermittency poses challenges to the operation of the electrical distribution network. Distribution system operators have to manage the grid in accordance with standards which defines minimum levels of quality of supply for end-users. Inclusion of these DERs and the flexibility that they offer is a key ingredient for the optimal operation of the distribution networks. That is one of the principal reasons that have pushed researchers all around the world to study a way of better representing and modelling distribution networks, in order to allow policy-makers and DSOs to have a more precise picture of the operation of the power system and support their decision-making process, nevertheless, the models used in the last years leaves something to be desired, especially in what simplicity and scalability refers. Objectives and constraints dealt within the optimisation of operation of a distribution network leads to non-convexity and non-linearity. In literature, this non-convexity is addressed by formulating the mathematical problem as a mixed integer conic programming formulation or by further approximating it into a mixed integer linear programming problem. However, applying these models requires an enormous amount of data, including the detailed topology of the distribution network providing specific results. When simulating market model for the EU-28, such a level of detailing of the distribution networks will be computationally very intensive and results lack generality. Therefore, Tractebel Engineering proposes a state-of-the art (non-convex) modelling of the distribution network based on a generalized formulation that help simplifying the mathematical problem and provides results that are representative for the considered areas (and not specific to one single feeder). Despite the nonconvexity, this model helps to decrease the computational efforts by modelling the distribution archetypes and the power flow methods in a generic way. This model optimizes the OPEX along with the running of the power flow resulting in the optimal load flow solution. This model is applicable when dealing with large geographical coverage, large time horizons and representative situations.

The key objective of this project is to programme in a mathematical software the model created by Tractebel and check the reasonableness of the obtained results in order to assess if this

approach works well in order to shed light regarding the operation of distribution grids under different flexibility solutions.

3.1 MATHEMATICAL MODELLING OF THE CORE MODEL

The model delivered by Tractebel uses a simple mathematical language which will not be shown in this master thesis due to confidentiality reasons, however, in the next section the coding of the model into GAMS (General Algebraic Modelling System), developed and programmed during the elaboration of this project will be explained and analysed in depth.

The objective of the present section is to describe the functioning and main assumptions and constraints of the core model. The model optimizes the dispatch of assets of an already existing grid composed of several voltage levels seeking the minimization of the operational costs of the grid while satisfying energy and security criteria.

OBJECTIVE FUNCTION:

The objective function of the core model consists on the minimization of the operational costs. The operational costs are defined as the cost of the losses and the cost of flexibility. The former considers all the costs associated to the power losses associated to the electrical flow, while the latter is based on the cost of activating the different flexibility solutions of the grid.

The following table explains the different elements considered in losses and flexibility.

Power losses	Flexibility of assets
Transmission losses: accounts for the active power loss due to the resistive component of the lines.	Load shifting: Describes the capacity of consumers to shift their load consumption during a certain time window.
Copper losses: power losses due to the resistive term of transformer's windings	Load shedding: Describes possibility of reducing the load consumption by a certain amount
Iron losses: corresponds to the losses due to the magnetic properties of the transformers	Generation Curtailment: Refers to the capacity of reducing the generation output of local DER.

Table 1. Terms considered in the objective function.

DISTRIBUTION NETWORK ARCHETYPES FOR SIMULATING FLEXIBILITY PROVIDED BY DISTRIBUTED ENERGY RESOURCES

The optimization of the problem is performed subject to constraints of energy supply, nominal operation and security. In every moment, the demand of consumers together with their possible flexibility should be satisfied. On the other hand, the voltages drop and the power flows in the feeders must respect the nominal ranges of operation. Finally, the power supply has to be done reserving enough capacity on feeders and transformers to deal with a possible failure in an arbitrary substation or line.

A different dispatch of the grid will have different economical and technical outcomes. For instance, reducing peak load on the grid can be performed by either increasing the shedding of loads or increasing the level of local generation. In the first case, power losses will decrease but the cost for the shedding will be high. In the second case, peak shaving will be performed (at typically zero cost) whereas the level of the voltage at that point of the network will raise. Optimal arbitration for finding the best trade-off in terms of costs while respecting technical constraints is therefore needed.

TIME-WINDOW OPTIMIZATION:

Due to the introduction of distributed generation and flexibility on the demand the operation of the network becomes a stochastic and time-dependent process. To reflect this fact the decision variables of the problem are expressed in different time steps through several periods. This implies that the general state of the grid will depend on the time, however, the optimization will be performed over the aggregation of all the time steps.

There is not a dependency or correlation between the different periods, and their selection should be carefully performed in order to represent accurately the situation of interest.

GENERAL DESCRIPTION OF THE NETWORK AND ASSUMPTIONS:

The network considered in the model is composed of three voltage levels, however, more levels can be easily added. The network considered is based on the Spanish distribution voltage levels which are basically; 110 KV, 20 KV and 0.4 KV.

At every voltage level several feeders connect the substations with the nodes of consumption and generation and obviously with the substation of the lower voltage level.

**DISTRIBUTION NETWORK ARCHETYPES FOR SIMULATING FLEXIBILITY PROVIDED BY
DISTRIBUTED ENERGY RESOURCES**

The next figure shows the schematic representation of the considered network with three voltage levels.

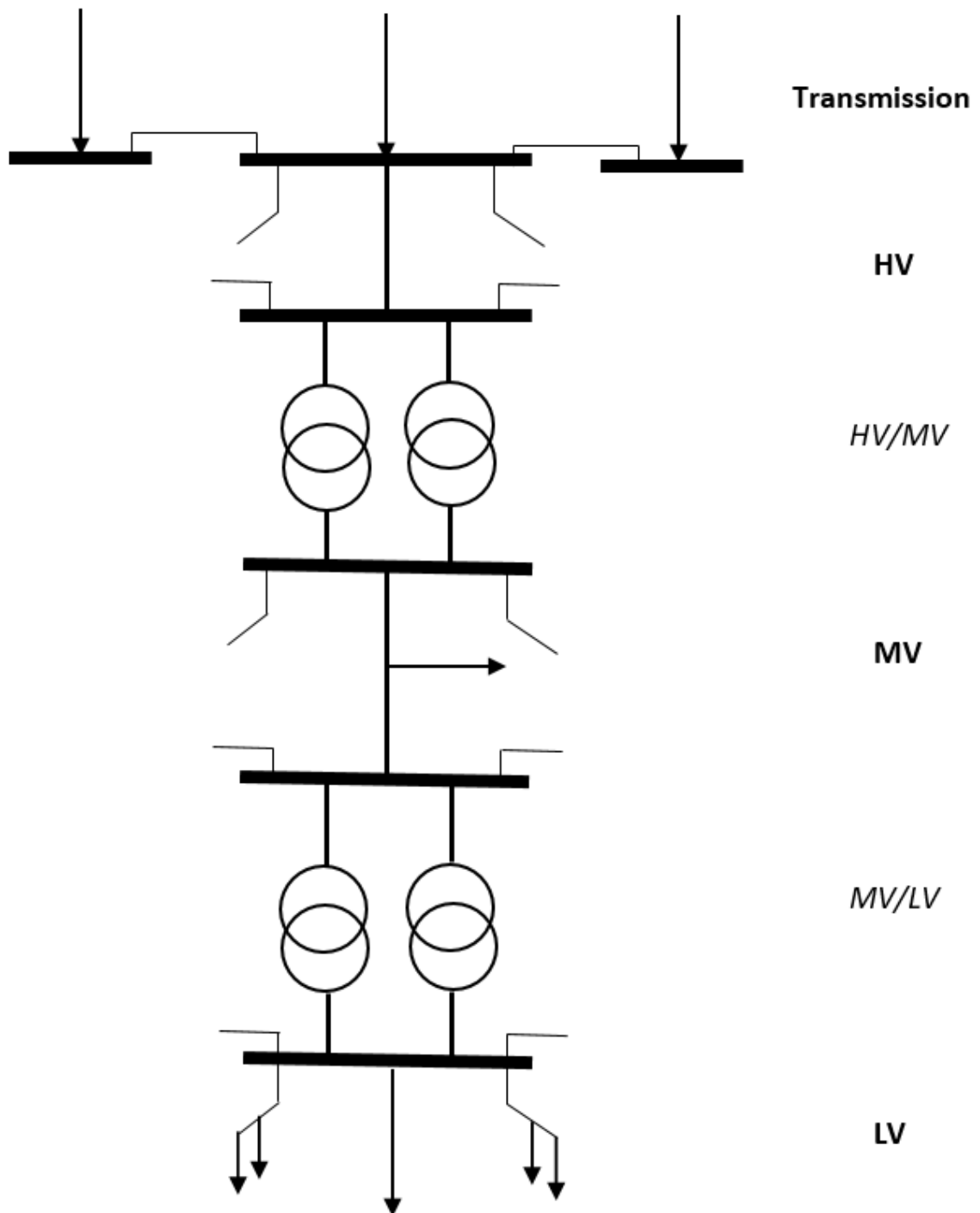

Figure 7. Representation of the network with three voltage levels and two conversion substations.

DISTRIBUTION NETWORK ARCHETYPES FOR SIMULATING FLEXIBILITY PROVIDED BY DISTRIBUTED ENERGY RESOURCES

Regarding substations, these are characterized by the number of transformers they contain and the nominal operation rate of each transformer. On behalf of the feeders, they will be described by their cross-section, their length, their conductivity and nominal power parameters.

ASSUMPTIONS AND PRE-REQUISITES FOR THE MODEL

The main remarkable characteristic of the core model is that it uses archetypes for each voltage level of the network. Archetypes are the topology of the grid assumed to be uniformly distributed over an infinite surface, therefore, main physical features of the grid can be expressed in a per-surface basis. This novelty allows the model to operate different archetypes depending on the architecture of the grid, for example, a rural distribution network will have a much lower demand or spread of wires and substation per area than an urban area. Also, each country will have dissimilar grid configurations that will result in other archetypes.

For each voltage level the following assumptions will be considered in the core model.

- Substations are uniformly distributed in space.
- Nominal power of transformers as well as their number per substation are equal.
- The number of feeders departing from a substation are the same.
- The section and type of conductors are uniform.
- Nodes of electrical consumption and generation is uniformly distributed in the space among the feeders.
- Consumption and generation nodes have respectively the same level of flexibility

3.2 CODING OF THE CORE MODEL IN GAMS

This next section will explain how the programming of the core model has been performed in GAMS, it will deeply analyse the coding language to later understand better what each code item implies and how the data to feed the model has been gathered.

First, the selection of the sets will be explained. Then the parameters and the variables of the model. Finally, a precise analysis of the equations used will be performed.

SETS:

According to GAMS users' guide, sets are the fundamental building block in any GAMS model. They are essential in order to define the identifiers of each parameter, equation and variable. The main sets of this core model are the voltage level (VL) which defines each voltage level and the Subperiods (T). This means that a variable that depends of the set VL will have a value for each different voltage level, in this case, three different values.

In the programme there are more sets that will be shown below, however, they were only created for a simplifying the coding of the core model.

Sets	Description
T	Subperiods of time , we can have as much as we want, each represent one hour of simulation. /t1, t2, t3, ..., tn/
VL	Voltage levels , three voltage levels in this case. /HV, MV, LV/
CVL	Characteristics of each voltage level . Contains the input parameters of each voltage level, i.e the demand and generation in that level.
CL	Characteristics of the lines . Contains the characteristics of the lines, i.e, the length and conductivity of each line.
CSB	Characteristics of substations . Contains the characteristics of the substations, i.e, the demand and generation at substation level.
CTR	Characteristics of transformers . Includes the physical characteristics of the transformers, i.e the parameters for the iron losses.

Table 2. Example of the set used in GAMS

**DISTRIBUTION NETWORK ARCHETYPES FOR SIMULATING FLEXIBILITY PROVIDED BY
DISTRIBUTED ENERGY RESOURCES**

The next figure is a picture of the GAMS code, so that the reader can see how this above-mentioned data is introduced in the software.

```
SETS
T                               Subperiods
VL                              Voltage Level
SB(vl,vl)                       Substations
LN(vl)                           Lines
CVL                             Characteristics of the network voltage levels
CL                              Characteristics of the lines
CSB                             Characteristics of the substations
CTR                             Characteristics of transformers
```

Figure 8. Implementation of the used SETS in GAMS

PARAMETERS:

Parameters are the simplest way in GAMS of introducing input data. It can have three different types, all of them have been used in the programming so they will be briefly explained in the following list:

- Scalar: single scalar data entry, just a value not dependant on any set
- Parameter: list-oriented data, defined over one or more sets.
- Table: Table oriented data, involves two or more dimensions.

The next picture shows the table parameter DATVL (vl, cvl), which is a set of information dependant on each voltage level and on each characteristic of each voltage level. The reader should not pay attention yet to the values included in the table, this is just an example so that the notion of a two-dimension parameter depending on two sets can be understood.

```
TABLE DATVL(vl,cvl)
      dem    gen    Voltage MU    Volt    Voltrise    number    p
HV     0      0     110    0.00154 0.1    0.1        1      100
MV     0      0     20     0.00693 0.1    0.1        1       50
LV     0      0     0.4    0.5738 0.1    0.1        1      0.25
```

Figure 9. Example of table parameter in GAMS

The next table contains the main parameters used in the programming of the core model. Just a brief description of each parameter, their dimensions and the depending sets will be listed.

**DISTRIBUTION NETWORK ARCHETYPES FOR SIMULATING FLEXIBILITY PROVIDED BY
DISTRIBUTED ENERGY RESOURCES**

Parameters	Type	Dimension	Sets	Description
C_x	Scalar	1	-	Weight factor. There are 7 different. They will be explained with the detailed study of the objective function.
DATVL	Table	2	vl, cvl	Includes the physical characteristics of each voltage level
DATVLT	Table	3	vl, cvl, t	Includes the value of generation and demand of each voltage level and for each subperiod of time
DATLIN	Table	2	vl, cl	Comprises the values of the lines for each VL
DATSUB	Table	3	vl, vl, csb	Contains the values for substation between two voltage levels and the characteristics of each substation
DATSUBT	Table	4	vl, vl, csb, t	Same as before but now with characteristics that are time-dependant.
DATTRANS	Table	2	vl, vl, ctr	Covers the data of the transformers between two voltage levels or in a substation.

Table 3. Parameters used in the model programming.

VARIABLES:

Variables are together with equations the most important item of the code. They are the decision variables that will obtain different values to satisfy all the set of equations and restrictions while optimizing the problem. In GAMS there are different types of variables depending on their boundaries. In this case, the programme uses free variables and positive variables with a lower bound of zero.

As parameters, variables can have diverse dimensions depending on the sets that they rely on. For example, a variable that expresses the losses on the lines will depend on the voltage level and on the subperiod of the simulation, taking three values (one for each voltage level) for each time simulation.

**DISTRIBUTION NETWORK ARCHETYPES FOR SIMULATING FLEXIBILITY PROVIDED BY
DISTRIBUTED ENERGY RESOURCES**

Table 4 follows the same structure as Table 3 and contains summarized information of the used variables in the program. Later a picture of the code will be shown to see how these variables are included in GAMS language.

Variable	Type	Dimension	Sets	Description
COST	Free	1	-	Variable of the objective function that the model tries to minimize
D	Free	2	t, vl	Power flow that enter the network at voltage level vl in the subperiod t
E	Free	2	t, vl	Power flow that exits the network at voltage level vl in the subperiod t
NC	Free	2	t, vl	Net load connected at voltage level vl
NCSB	Free	2	t, vl	Net load connected at the substation in voltage level vl
EPSILON	Free	2	t, vl	Maximum load rate of transformers in vl
NAC	Free	2	t, vl	Negative load shifting
SNAC	Free	3	t, vl, vl	Negative load shifting in the substation
PSI	Positive	2	t, vl	Power losses in the line
CS	Positive	2	t, vl	Shed load in the network
SCS	Positive	3	t, vl, vl	Shed load in the substation
AG	Positive	2	t, vl	Curtailed generation in the network
SAG	Positive	3	t, vl, vl	Curtailed generation in the substation
GAMMA	Positive	3	t, vl, vl	Transformer copper losses
FI	Positive	2	VI, vl	Iron losses in the transformer
AC	Positive	2	t, vl	Load shifting in the network
SAC	Positive	3	t, vl, vl	Load shifting in the substation
PAC	Positive	2	t, vl	Positive load shifting in the network
SPAC	Positive	3	t, vl, vl	Positive load shifting in the substation

Table 4. Variables used in the GAMS coding

DISTRIBUTION NETWORK ARCHETYPES FOR SIMULATING FLEXIBILITY PROVIDED BY DISTRIBUTED ENERGY RESOURCES

All the variables except COST and EPSILON have MW/km² units, COST has monetary units and EPSILON is in p.u.

Next figure shows the implementation of the variables in the GAMS language code.

```
VARIABLES
COST                Objective function
D(t,vl)            Power flow that enters the network at voltage level vl
E(t,vl)            Power flow that exits the network at voltage level vl
NC(t,vl)           Net load connected at voltage level vl
NCSB(t,vl)         Net load connected at Substation sb in vl
EPSILON(vl,vl)     Maximum load rate of transformers in vl
NAC(t,vl)          Negative load shifting
SNAC(t,vl,vl)      Negative load shifting in the substation

POSITIVE VARIABLES
PSI(t,vl)          Power losses in the line
CS(t,vl)           Shed Load
SCS(t,vl,vl)       Shed Load in the substation
AG(t,vl)           Curtailed generation
SAG(t,vl,vl)       Curtailed generation in the substation
GAMMA(t,vl,vl)     Transformer copper Losses
FI(vl,vl)          Iron losses in the transformer
AC(t,vl)           Load shifting
SAC(t,vl,vl)       Load shifting in the substation
PAC(t,vl)          Positive load shifting
SPAC(t,vl,vl)      Positive load shifting in the substation
```

Figure 10. Variables used in the code programming in GAMS

EQUATIONS:

The following section will analyse the equations implemented in GAMS.

ENERGY BALANCE:

Here, the equations of the energy balance that rule the transmission of power between and within voltage levels are described in detail.

$D(t,vl)$ expresses the power per-surface that enters the network at a moment t in every voltage level, on the other hand, $E(t,vl)$ is the power per-surface that exists the network at voltage level vl for every time t .

The first power balance equation is:

$$D(t, vl) = E(t, vl) + NC(t, vl) + PSI(t, vl)$$

**DISTRIBUTION NETWORK ARCHETYPES FOR SIMULATING FLEXIBILITY PROVIDED BY
DISTRIBUTED ENERGY RESOURCES**

$NC(t, vl)$ is the net load connected at the network in that voltage level, this is the load and generation connected in the feeders, after, the equation that rules the net load will be explained. $PSI(t, vl)$ expresses the losses in the lines due to the power flows.

The next equation is similar to the previous one but states the energy balance inside substations.

$$D(t, vl + 1) = E(t, vl) - NCSB(t, vl) - FI(vl, vl + 1) - GAMMA(t, vl, vl + 1)$$

$NCSB(t, vl)$ is the same expression as NC , but in this case, is the net load connected at substation level. $FI(vl, vl)$ makes reference to the iron losses that occur in the transformer. Lastly, $GAMMA(t, vl, vl)$ indicates the copper losses inside the transformers.

In the topology used during the programming in GAMS it has been defined that if $vl+1$ is the next lower voltage level of the grid. For example, if vl takes the value 'High Voltage', $vl+1$ will be the value 'Medium voltage' and so on.

The next figure puts both equations together in a graphic form to simplify the understanding of the relation between the energy balance equations. Note that the graph shows and snap of the energy balance so the set time (t) is not considered. Also, the set voltage level (vl) has been substituted for the value of the voltage level.

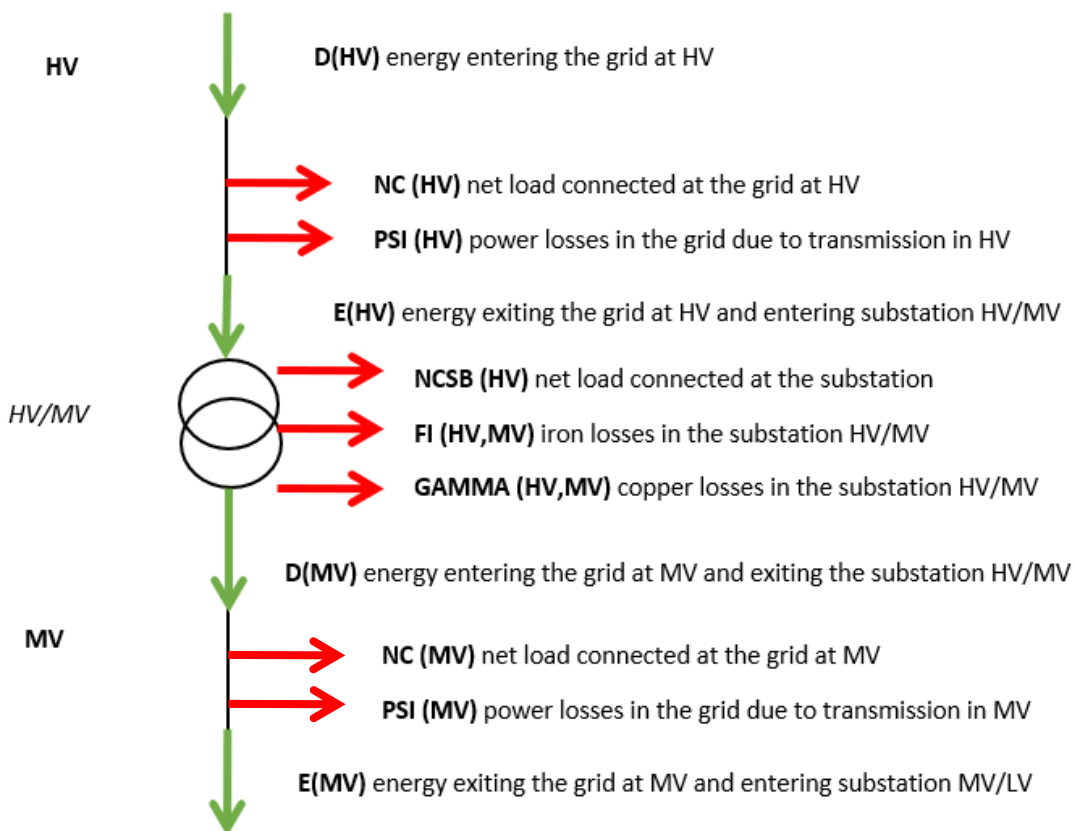

Figure 11. Example of the power flows in the energy balances equations.

**DISTRIBUTION NETWORK ARCHETYPES FOR SIMULATING FLEXIBILITY PROVIDED BY
DISTRIBUTED ENERGY RESOURCES**

The both mentioned equations are implemented in GAMS in the following way:

```
EB1(t,vl) .. D(t,vl) =E= E(t,vl)+PSI(t,vl)+NC(t,vl);
EB2(t,vl) .. D(t,vl+1) =E= E(t,vl)-GAMMA(t,vl,vl+1)-NCSB(t,vl)-FI(vl,vl+1);
```

Figure 12. Example of the implementation of the energy balance equation in GAMS

NOMINAL OPERATION OF SUBSTATIONS:

This section shows the equations that rule the nominal operation of substations.

The nominal power of a substation between two voltage levels, matches with the nominal power (p) of the number of transformers (m) that constitute that substation. Being ε the maximum load rate of each transformer, the nominal power that can be transmitted has to comply with the following equations:

$$\varepsilon(vl, vl + 1) \geq \frac{E(t, vl)}{\mu(vl, vl + 1) * m(vl, vl + 1) * p(vl, vl + 1)}$$

$$\varepsilon(vl, vl + 1) \geq \frac{-D(t, vl)}{\mu(vl, vl + 1) * m(vl, vl + 1) * p(vl, vl + 1)}$$

Being μ the number of substations per unitary surface for each voltage level. One notes that the second equation with the term -D accounts for possible reverse flows.

If c is the number of substations that can participate in a mutual support process during a contingency, it can be defined that in case of a failure in the transformer of a substation, the power that can be transferred to the rest substations follows the next equation:

$$C(vl, vl + 1) \times [m(vl, vl + 1) - 1] \times [1 - \varepsilon(vl, vl + 1)] \geq \varepsilon(vl, vl + 1)$$

These three equations are implemented in GAMS as follows in the next figure:

```
SBSNOMPOW1(t,vl,vl+1) .. EPSILON(vl,vl+1) =G= [E(t,vl)/((DATSUB(vl,vl+1,'MU'))*(DATTRANS(vl,vl+1,'m'))*(DATTRANS(vl,vl+1,'p')))];
SBSNOMPOW2(t,vl,vl+1) .. EPSILON(vl,vl+1) =G= [-D(t,vl+1)/((DATSUB(vl,vl+1,'MU'))*(DATTRANS(vl,vl+1,'m'))*(DATTRANS(vl,vl+1,'p')))];
MUTSUP(vl+1) .. [(DATSUB(vl,vl+1,'number'))*(DATTRANS(vl,vl+1,'m'))-1]*[1-EPSILON(vl,vl+1)] =G= EPSILON(vl,vl+1);
```

Figure 13. Implementation of the nominal operation equations in GAMS.

NOMINAL OPERATION OF CABLES:

Regarding feeders, there are also two equations that determine that their behaviour is not above maximum operation conditions.

The first equation is the security constraint that limits the power flow through feeders below their maximum capacity.

**DISTRIBUTION NETWORK ARCHETYPES FOR SIMULATING FLEXIBILITY PROVIDED BY
DISTRIBUTED ENERGY RESOURCES**

$$P_{max}(vl) \geq \lambda(vl) \times \frac{D(t, vl)}{\mu(vl) * k(vl)}$$

$$P_{max}(vl) \geq \lambda(vl) \times \frac{E(t, vl)}{\mu(vl) * k(vl)}$$

Pmax is the conductor maximum capacity, D and μ have been already explained, and λ accounts for the reliability coefficient of the cables, this is always bigger than 1 and acts as a security margin. Finally, k represents the number of feeders departing from a substation.

For computational reasons when programming these equations in GAMS, four equations have to be implemented in order to account for possible reverse flows. This issue could have been solved defining the power flows as absolute values.

```
SECCABLES1(t,vl) .. (DATLIN(vl, 'Pmax')) =G= [(DATLIN(vl, 'Reliability')) * D(t, vl)] / [(DATVL(vl, 'MU')) * (DATLIN(vl, 'number'))];
SECCABLES2(t,vl) .. (DATLIN(vl, 'Pmax')) =G= [(DATLIN(vl, 'Reliability')) * E(t, vl)] / [(DATVL(vl, 'MU')) * (DATLIN(vl, 'number'))];
SECCABLES3(t,vl) .. (DATLIN(vl, 'Pmin')) =L= [(DATLIN(vl, 'Reliability')) * D(t, vl)] / [(DATVL(vl, 'MU')) * (DATLIN(vl, 'number'))];
SECCABLES4(t,vl) .. (DATLIN(vl, 'Pmin')) =L= [(DATLIN(vl, 'Reliability')) * E(t, vl)] / [(DATVL(vl, 'MU')) * (DATLIN(vl, 'number'))];
```

Figure 14. Implementation of the above-mentioned equations in GAMS.

VOLTAGE VARIATIONS:

The flow of energy through the feeders, together with the influence of active and reactive components in the power lines, will generate variations on the magnitude of the voltage. The sign of the variation will depend on the power flow, if it goes from upper voltage levels to lower voltage levels, a voltage drop will occur, in the case of reverse flows where the power goes from lower voltage levels to higher voltage levels, a voltage rise will take place. Every distribution grid has a maximum allowed voltage drop and rise. The next two equations control the above explained phenomena to avoid the voltage variations to be bigger than a certain threshold.

$$VOLT(vl) \geq \frac{D(t, vl) \times L(vl) \times \rho(vl)}{[\mu(vl) \times k(vl) \times V(vl)]^2} + \left[\frac{D(t, vl) \times L(vl) \times X(vl)}{[\mu(vl) \times k(vl) \times V(vl)]^2} \right] \times \tan \Phi(vl)$$

$$VOLTRISE(vl) \geq \frac{-D(t, vl) \times L(vl) \times \rho(vl)}{[\mu(vl) \times k(vl) \times V(vl)]^2} - \left[\frac{D(t, vl) \times L(vl) \times X(vl)}{[\mu(vl) \times k(vl) \times V(vl)]^2} \right] \times \tan \Phi(vl)$$

Where VOLT(vl) and VOLTRISE(vl) determine the allowed value for voltage drop and voltage rise respectively. V(vl) is the voltage of the grid in that voltage level, L(vl) comprises the length of the feeders, $\rho(vl)$ and X(vl) accounts for the conductivity and reactance respectively of the feeders, and finally, the $\Phi(vl)$ expresses the angle of the voltage-current in the grid.

CABLE LOSSES:

The losses in the feeders due to the Joule effect, $\Psi(t, vl)$ are ruled by the following two inequalities in order to account for possible reverse flows.

These equations calculate the power lost on per-surface unit in the feeders in each time period t and for each voltage level.

$$\Psi(t, vl) \geq \left(\frac{D(t, vl)}{k(vl) \times \mu(vl)} \right)^2 \times \frac{L(vl) \times \rho(vl)}{V(vl)^2}$$

$$\Psi(t, vl) \geq \left(\frac{E(t, vl)}{k(vl) \times \mu(vl)} \right)^2 \times \frac{L(vl) \times \rho(vl)}{V(vl)^2}$$

The variable $\Psi(t, vl)$ in GAMS is defined as PSI due to the impossibility of putting symbols in GAMS. This happens with more variables and parameters, their name in the programme is the name of the letter instead of the symbol itself.

TRANSFORMER COPPER LOSSES:

Similar to the previous case, the losses caused by the cooper effect $\Gamma(t, vl)$ in the transformers are bounded by two inequalities:

$$\Gamma(t, vl) \geq E(t, vl)^2 \times \frac{T(vl)}{\mu(vl) \times m(vl) \times p(vl)}$$

$$\Gamma(t, vl) \geq D(t, vl)^2 \times \frac{T(vl)}{\mu(vl) \times m(vl) \times p(vl)}$$

$T(vl)$ is the equivalent resistivity of the transformer, the remaining variables have already been explained.

These equations are implemented in GAMS as follows:

```
TCOPLOSSES1(t,vl,vl+1) .. GAMMA(t,vl,vl+1) =G= [E(t,vl)*E(t,vl)]*[DATSUB(vl,vl+1,'EqResistance')]/[(DATSUB(vl,vl+1,'MU'))*(DATTRANS(vl,vl+1,'m'))*(DATTRANS(vl,vl+1,'p'))];
TCOPLOSSES2(t,vl,vl+1) .. GAMMA(t,vl,vl+1) =G= [D(t,vl)*D(t,vl)]*[DATSUB(vl,vl+1,'EqResistance')]/[(DATSUB(vl,vl+1,'MU'))*(DATTRANS(vl,vl+1,'m'))*(DATTRANS(vl,vl+1,'p'))];
```

Figure 15. Implementation of the copper losses in GAMS.

TRANSFORMER IRON LOSSES:

The losses caused by the iron effect $\Phi(vl)$ are not time-dependent since it depends exclusively by the physical configuration of the transformer.

$$\Phi(vl) = \mu(vl) \times m(vl) \times (u_1(vl) + u_2(vl) \times p(vl)^{u_3})$$

**DISTRIBUTION NETWORK ARCHETYPES FOR SIMULATING FLEXIBILITY PROVIDED BY
DISTRIBUTED ENERGY RESOURCES**

The coefficients u_1 , u_2 and u_3 where determined experimentally and their values will be shown in following section.

```
TIRONLOSSES(vl,vl+1) .. FI(vl,vl+1) =G= [DATTRANS(vl,vl+1,'u1')+[DATTRANS(vl,vl+1,'u2')*[DATTRANS(vl,vl+1,'p')**DATTRANS(vl,vl+1,'u3')]]];
```

Figure 16. Implementation of the iron losses equation in GAMS.

FLEXIBILITY:

The present section explains the equations and constraints that regulate the flexibility options considered in this mathematical model which are three; load shifting, load shedding and generation curtailment. They are expressed as decision variables that can be activated at every time step at a certain cost. Electric vehicle and storage are not considered among the possible flexibility options; however, it would be very interesting to add them in the model when a deeper analysis wants to be performed.

NET DEFINITION LOAD:

Net load, expressed as $NC(t,vl)$, is a variable that represents the net power consumption of the ensemble of nodes at voltage level vl in a certain time period t . It can be expressed as a function of the demand and the generation. The demand term considers the initial load demand, which is an input data, the $AC(t,vl)$ variable, which is the load shifting value and the load shedding option expressed by $CS(t,vl)$. On the other side, the generation term is expressed by the input generation data minus the associated curtailed generation, $AG(t,vl)$.

$$NC(t, vl) = [DATVLT(vl, 'dem', t) - AC(t, vl) - CS(t, vl)] - [DATVLT(vl, 'gen', t) - AC(t, vl)]$$

Except the input parameters, the other are decision variables determined by the model according to the best economical outcome.

The previous equation has its similar application at substation level, this is something important to take into account as for example, curtail generation directly connected to a substation may be cheaper.

The equation that controls the net definition in a substation is expressed as follows:

$$NCSB(t, vl) = [DATSUBT(vl, vl + 1, 'dem', t) - SCS(t, vl, vl + 1) - SAC(t, vl, vl + 1)] - [DATSUBT(vl, vl + 1, 'gen', t) - SAG(t, vl, vl + 1)]$$

DISTRIBUTION NETWORK ARCHETYPES FOR SIMULATING FLEXIBILITY PROVIDED BY DISTRIBUTED ENERGY RESOURCES

As in the previous case, the initial demand and generation directly connected to the substation are input fixed parameters, while the SCS (load shedding), SAC (load shifting) and SAG (generation curtailment) are decision variables that will change their value depending on their associated cost.

```
NETC(t,vl) .. NC(t,vl) =E= (DATVLT(vl,'dem',t)-AC(t,vl)-CS(t,vl))-[DATVLT(vl,'gen',t)-AG(t,vl)];
NETCSB(t,vl) .. NCSB(t,vl) =E= (DATSUBT(vl,vl+1,'dem',t)-SCS(t,vl,vl+1)-SAC(t,vl,vl+1))-[DATSUBT(vl,vl+1,'gen',t)-SAG(t,vl,vl+1)];
```

Figure 17. Implementation of the net load equations in GAMS.

The above shown figure represents the implementation of the net load definition equations in the GAMS code.

LIMITATIONS ON LOAD SHIFTING:

The load shifting option is the ability of moving a load from a time period to later. This process can be performed during a specific time window and the total load of the time window must be satisfied.

For doing this, the next two equations are defined:

$$\sum_{t=1}^{fw} AC(t, vl) = 0$$

$$\sum_{t=1}^{fw} SAC(t, vl) = 0$$

Being fw the time window formed by the required time periods t . AC is the load shifted in the network while SAC is the load shifted directly connected to a substation.

COST FUNCTION:

The optimization of the optimal power flow dispatch is done on the operational costs of the distribution network.

In a first schematic approach, the optimization function can be defined as:

$$\min [COST(losses) + COST(flexibility)]$$

Now, the cost of each option will be defined.

**DISTRIBUTION NETWORK ARCHETYPES FOR SIMULATING FLEXIBILITY PROVIDED BY
DISTRIBUTED ENERGY RESOURCES**

Regarding the losses, the model will consider two type of losses, the power losses, which will have a cost associated to the peak demand of the whole operation of the grid and on the other hand, the energy losses, which have a cost associated to the power dissipation.

The power losses are calculated as follows:

$$C_7 \times \max(t, \sum_{vl} \Psi(t, vl) + \sum_{vl} \Gamma(t, vl, vl + 1) + \sum_{vl} \Phi(vl, vl + 1))$$

The above shown equation calculates the sum of all the losses in each voltage level and through all the time steps and gets the maximum value of the sum, then multiplies this value by a constant (C_7) which corresponds to the proportionality cost factor of the power losses.

Regarding the energy losses, these are calculated in a similar way than the previous ones, but now for every time step we want the total losses that have occurred. That is done by the next equation.

$$C_8 \times \sum_t \left[\sum_{vl} \Psi(t, vl) + \sum_{vl} \Gamma(t, vl, vl + 1) + \sum_{vl} \Phi(vl, vl + 1) \right]$$

Like in the previous case, here, C_8 is the associated cost parameter to the energy losses.

The next equations will try to calculate the associated cost of the different flexibility solutions that may happen. The idea of these calculations is again, associate a cost parameter to each option and multiply the value of the decision variable that reflects the flexibility by the cost.

About load shedding, the cost associated to this are replicated by C_9 and C_{9R} , the first for the grid and the second for the substations. The equations are as follow:

$$C_9 \times \sum_t \sum_{vl} CS(t, vl)$$

$$C_{9R} \times \sum_t \sum_{vl} SCS(t, vl, vl + 1)$$

Same methodology can be used for generation curtailment, with the associated cost expressed as C_{10} and C_{10R} , once again, being the second one the associated to generation curtailment directly connected to the substations.

$$C_{10} \times \sum_t \sum_{vl} AG(t, vl)$$

$$C_{10R} \times \sum_t \sum_{vl} SAG(t, vl, vl + 1)$$

Finally, the costs of load shifting must be computed in a similar way.

$$C_{11} \times \sum_t \sum_{vl} AC(t, vl)$$

$$C_{11R} \times \sum_t \sum_{vl} SAC(t, vl, vl + 1)$$

The overall cost function that the model will try to minimize can be written as the addition of all the previous cost equations:

$$\begin{aligned} COST = & C_7 \times \max(t, \sum_{vl} \Psi(t, vl) + \sum_{vl} \Gamma(t, vl, vl + 1) + \sum_{vl} \Phi(vl, vl + 1)) \\ & + C_8 \times \sum_t \left[\sum_{vl} \Psi(t, vl) + \sum_{vl} \Gamma(t, vl, vl + 1) + \sum_{vl} \Phi(vl, vl + 1) \right] \\ & + C_9 \times \sum_t \sum_{vl} CS(t, vl) + C_{9R} \times \sum_t \sum_{vl} SCS(t, vl, vl + 1) \\ & + C_{10} \times \sum_t \sum_{vl} AG(t, vl) + C_{10R} \times \sum_t \sum_{vl} SAG(t, vl, vl + 1) \\ & + C_{11} \times \sum_t \sum_{vl} AC(t, vl) + C_{11R} \times \sum_t \sum_{vl} SAC(t, vl, vl + 1) \end{aligned}$$

SOLVE TFM USING DNLP MINIMIZING COST;

Figure 18. Final line in GAMS where the solver is defined.

Figure 17 shows one of the last lines of the GAMS code where the variable of the objective function, cost, has to be minimize.

4. ANALYSIS OF THE SCENARIOS AND RESULTS

This section will entail the running of simulation cases and the analysis of the obtained results.

First, once the model has been programmed in GAMS, some simulation tests have to be performed to be sure that the results that the model is obtaining are sensible and make sense.

4.1 CHEKING THE FEASIBILITY OF THE MODEL

In order to determine if the results that the model provide are correct several tests are going to be performed with real hourly data of Spain. Two main features are going to be analysed. First, the mathematical coherence of the model, examining if the results comply with the equations. Secondly, the obtained results of some decision variables as for example, the losses in the iron of the transformers, the line losses or the load rate of the transformers will be studied to see if their values are among the expected standards for these parameters in a typical distribution network.

For this first test, only 1-hour simulation will be performed under different load scenarios, as the main focus is to check the value of technical variables, the analysis of the operation of the grid with flexibility solutions will come later.

Three load scenarios are considered for this study, a scenario of low demand, one of medium demand, and last, one of high demand. The demands are separated in voltage levels and are the real values of Spain for the year 2018, obtained from Red Electrica website. The next table shows these values.

DATE	Sunday,15-abr 5AM	Saturday, 24-Feb 3PM	Wednesday, 17-Jan 9PM
Voltage level	Low demand [MW]	Medium Demand [MW]	High Demand [MW]
HV	1172,072	1273,51	1097,748
MV	5058,348	6671,801	8703,794
LV	6319,237	12973,006	20706,714

**DISTRIBUTION NETWORK ARCHETYPES FOR SIMULATING FLEXIBILITY PROVIDED BY
DISTRIBUTED ENERGY RESOURCES**

Total	12549,657	20918,317	30508,256
--------------	------------------	------------------	------------------

Table 5. Demand scenarios considered

These are going to be the input demands at each voltage level for the model test. Take into account that these demand in MW have to be introduced in the model as per-surface units, so everything has to be divided by the surface of Spain, which is 504.782 km².

The expected results, if the model have worked well and is correctly programmed is to find the same iron losses in every scenario as it does not depend on the load and obtain bigger copper and line losses when the demand is bigger.

The final input data will be:

Voltage level	Low demand [MW/km²]	Medium Demand [MW/km²]	High Demand [MW/km²]
HV	0,002321937	0,002522891	0,002174697
MV	0,010020857	0,013217193	0,017242679
LV	0,012518745	0,025700215	0,041021102

Table 6. Demand in per-surface units.

The most important input parameters and data to feed the model are shown in the next three tables. First the data of the technical requirements of each voltage level, the second table gathers the data of the cables and feeders. Finally, the last table collects the data related to transformers and substations.

Voltage level	Voltage [KV]	Voltdrop [%]	Voltrise [%]	Cos(Φ)
HV	110	10	10	0.97
MV	20	10	10	0.97
LV	0,4	10	10	0.97

Table 7. Input data of the voltage levels.

**DISTRIBUTION NETWORK ARCHETYPES FOR SIMULATING FLEXIBILITY PROVIDED BY
DISTRIBUTED ENERGY RESOURCES**

Voltage level	Λ [pu]	Pmax [MW]	Number	Length [km/km ²]	P [Ω /km]	X [Ω /km]
HV	1.1	± 141	1	0.062	0.1466	0.4
MV	1.1	± 16.9	3	0.556	0.0916	0.104
LV	1.1	± 0.185	2	0.759	0.211	0.22

Table 8. Input data of the feeders.

Voltage level	Number	P [MVA]	Eq. Resistance [%]	μ [1/km ²]	U ₁	U ₂	U ₃
HV/MV	2	50	0,6	0.006934	-0.00021	0.00082	1
MV/LV	2	0,25	4	0.573854	0.000133	0.000766	1

Table 9. Input data of the transformers and substations.

From the above shown data provided by the IIT we can infer the total installed capacity of transformers in Spain, which will be useful to compare it with the iron losses in the next step of this analysis. The total installed capacity is:

$$P_{trafo} = 50 \times 2 \times 0,006934 \times 504.782 = 350.015 \text{ MVA (HV/MV)}$$

$$P_{trafo} = 0,25 \times 2 \times 0,573854 \times 504.782 = 144.835 \text{ MVA (MV/LV)}$$

SCENARIO 1: LOW DEMAND

As the reader may have already notice, the input data of the model is in per-surface units, likewise, the output data of the model will be also given in that same per-surface units.

The input parameters for this simulation are the ones shown in table 6, 7, 8 and 9.

The next table will show the obtained results for the low demand scenario; it must be said, that the results have already been multiplied per the surface of Spain (504782 km²) so that the values are more easily compared among them.

**DISTRIBUTION NETWORK ARCHETYPES FOR SIMULATING FLEXIBILITY PROVIDED BY
DISTRIBUTED ENERGY RESOURCES**

Voltage L.	Demand [MW]	D [MW]	E [MW]	Ψ [MW]	Γ [MW]	Φ [MW]
HV	1172,07	13317,41	12034,05	111,30	3,03	285,55
MV	5058,34	11745,46	6606,63	80,51		
LV	6319,23	6380,54	0	61,28	38,11	187,98
TOTAL	12549,65	-	-	253,09	41,14	473,53
% Demand	100 %	-	-	2,02 %	0,33 %	3,77 %

Table 10. Results for the low demand scenario.

The iron losses represent a 3,77% of the total demand, however, it can be more illustrative to compare these values with the transformers installed capacity. In HV/MV there are 350015 MVA, and 285,55 MW of losses, which represents a 0.08% of the installed capacity. In MV/LV there are 144835 MVA, the iron losses (Φ) obtained representing a 0.13% of the capacity. According to Schneider Electric, the typical iron losses of transformer varies depending on their capacity, nevertheless, there are ranging between 0.05% and 0.1 % of the nominal capacity of the equipment, in this case the obtained iron losses can be accepted as trustful values.

The losses due to power flows, both the line losses (Ψ) and the copper losses (Γ) in the transformers are unusually short, this is due to the extremely low level of loading of the network. Lines in HV are loaded just a 13% of the nominal capacity. Substations are loaded a 12% for HV/MV and a 20% for MV/LV which are also very short levels of charge, reason why the losses are so small.

To sum up, the losses represent a 6.12% of the total demand which is a small share that is expected to increase in the next cases, where a higher demand will generate bigger power flows and the losses will increase in a quadratic way with the flows.

To facilitate to the reader the understanding of the above revealed results they will be represented in a schematic view, similar to the one used in figure 10.

**DISTRIBUTION NETWORK ARCHETYPES FOR SIMULATING FLEXIBILITY PROVIDED BY
DISTRIBUTED ENERGY RESOURCES**

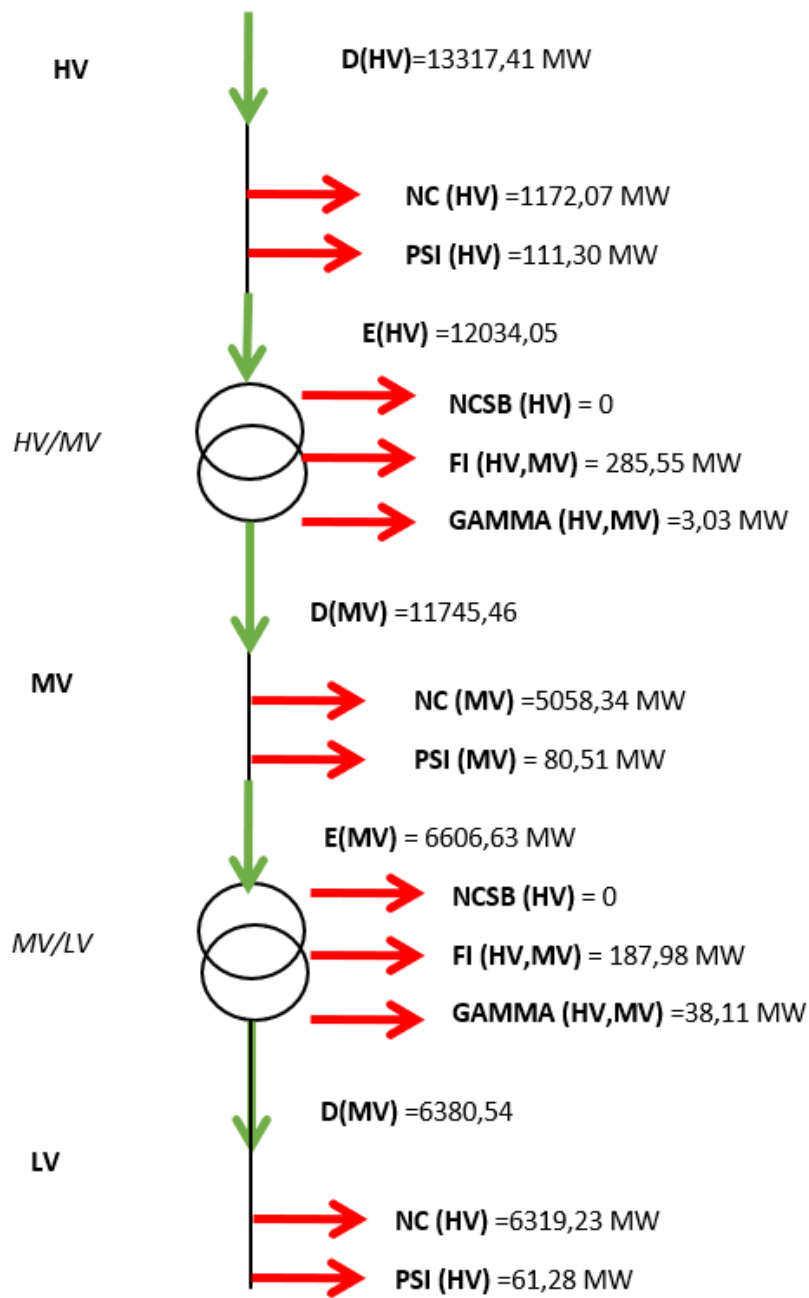

Figure 19. Scheme of the power flows for the low demand scenario.

SCENARIO 2: MEDIUM DEMAND

In this scenario, the demand has increased till the values shown in Table 6. This demand happened on a Saturday at 3PM on the month of February.

The input parameters shown in tables 7, 8 and 9 are the same for this scenario.

**DISTRIBUTION NETWORK ARCHETYPES FOR SIMULATING FLEXIBILITY PROVIDED BY
DISTRIBUTED ENERGY RESOURCES**

In this case, it is expected for the copper and line losses to increase and to be also a bigger share of the total energy demanded.

The obtained results are shown in the table below:

Voltage L.	Demand [MW]	D [MW]	E [MW]	Ψ [MW]	Γ [MW]	Φ [MW]
HV	1273,51	22337,05	20750,47	313,06	8,53	285,55
MV	6671,80	20456,39	13540,37	244,21		
LV	12973,00	13236,80	0	263,79	115,54	187,98
TOTAL	20918,317	-	-	821,078	124,07	473,53
% Demand	100 %	-	-	3,92 %	0,59 %	2,26 %

Table 11. Obtained results in the medium demand scenario.

Logically, iron losses have not changed, however, due to the increase of the demand its share has decreased till a 2,26%. Losses in the lines and in the copper have increased to normal levels, as they are almost a 4% and 0.6% of the total energy demanded.

Regarding the load on transformer and lines we find that the most loaded lines are the HV ones with a loading of the 22% of the nominal capacity. Transformers of HV/LV are loaded almost at 25% of their nominal capacity. These results suggest that for an average demand, the grid is extremely over dimensioned.

Again, the results are going to be shown in a schematic way so that the reader can track better the power flows.

**DISTRIBUTION NETWORK ARCHETYPES FOR SIMULATING FLEXIBILITY PROVIDED BY
DISTRIBUTED ENERGY RESOURCES**

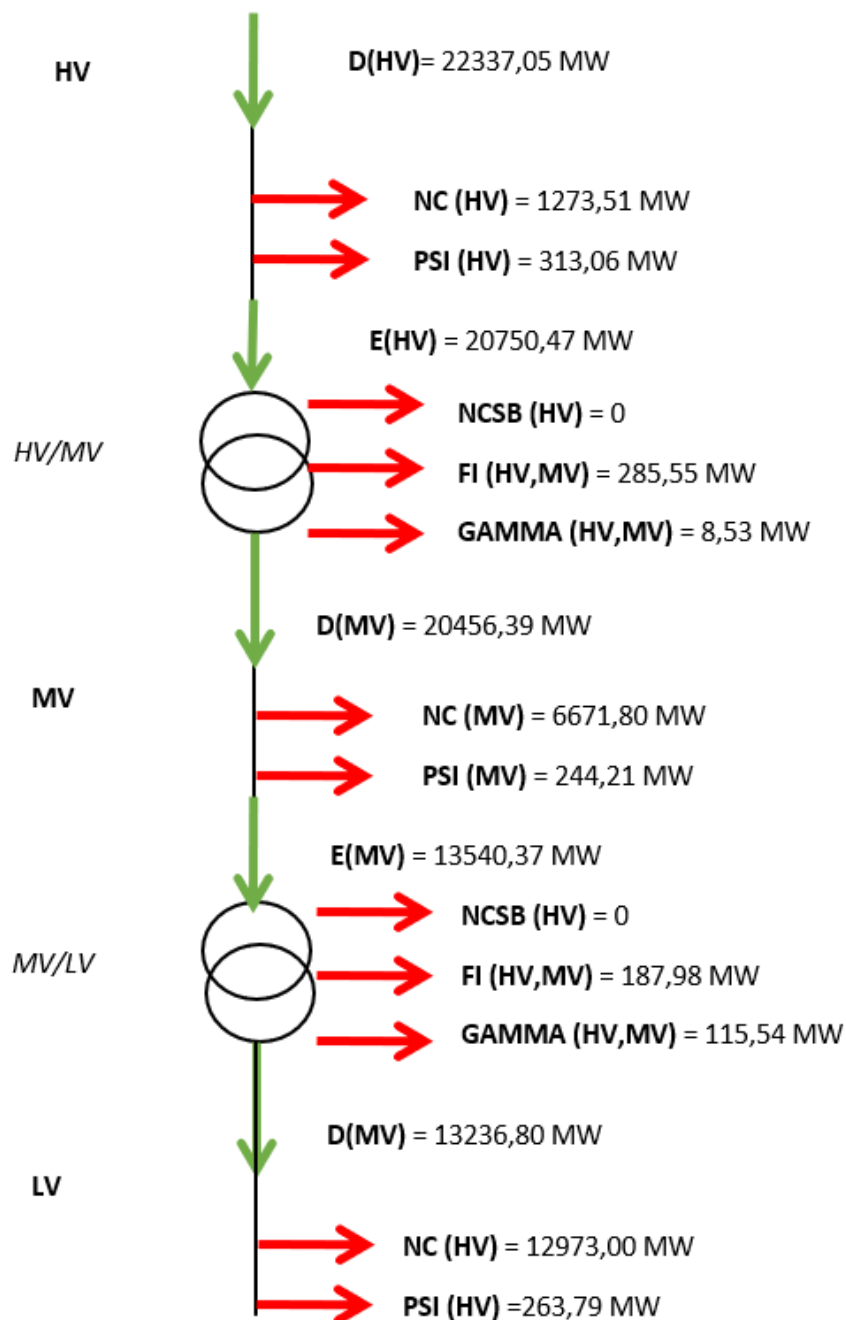

Figure 20. Scheme of the power flows for the medium demand scenario.

In this case, the losses despite being bigger than in the previous case, represent a 6,78% of the total demand. This value is close to what is expected in a distribution grid in Spain.

SCENARIO 3: HIGH DEMAND

In this last testing scenario, the demand used for the simulation is the one shown in the table 6 and corresponds to a Wednesday of a very cold week in winter during peak hour of the day (9pm). Again, the input parameters shown in tables 7, 8 and 9 remain unchanged for this simulation.

**DISTRIBUTION NETWORK ARCHETYPES FOR SIMULATING FLEXIBILITY PROVIDED BY
DISTRIBUTED ENERGY RESOURCES**

In this high demand scenario, the losses in the lines and in the copper of the transformers are expected to rise, however, due to the increase of the demand, their share of the total energy may not grow as much as expected.

The obtained results are shown in the table below:

Voltage L.	Demand [MW]	D [MW]	E [MW]	Ψ [MW]	Γ [MW]	Φ [MW]
HV	1097,74	33214,85	31424,85	692,25	18,93	285,55
MV	8703,79	31120,41	21851,45	565,20		
LV	20706,71	21395,99	0	689,27	267,48	187,98
TOTAL	30508,25	-	-	1946,74	286,41	473,53
% Demand	100 %	-	-	6,38 %	0,93 %	1,55 %

Table 12. Obtained results for the high demand scenario.

As expected, the total losses have increased considerably reaching 2706 MW, value that accounts for an 8,86 % of the total demand. The attained values of losses for these three cases comply with what was expected, having a percentage of losses ranging from a 6 % to almost a 9 % depending on the demand.

Loading on the HV lines reached a 33% of the nominal capacity, while the transformers of MV/LV were at 30% of their nominal capacity. These results depict that despite the high load, the distribution network is over-dimensioned as it would have comfortably complied with the N-1 criteria with these levels of loading.

The next figure shows the schematic representation of the power flows as it has been done in the previous two scenarios.

**DISTRIBUTION NETWORK ARCHETYPES FOR SIMULATING FLEXIBILITY PROVIDED BY
DISTRIBUTED ENERGY RESOURCES**

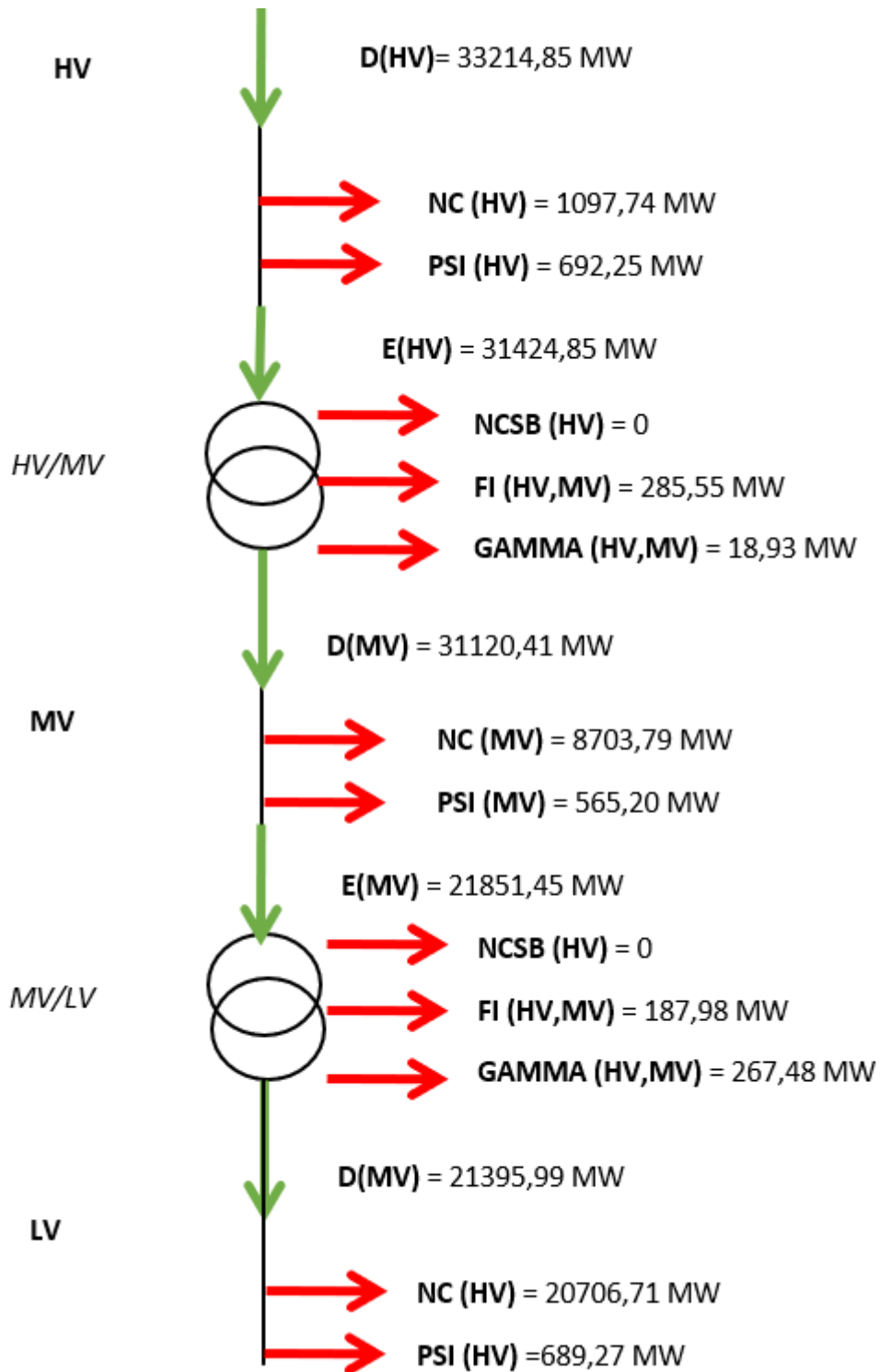

Figure 21. Scheme of the power flows in the high demand scenario.

After analysing the obtained results during these three scenarios it can be concluded that the model and the input parameters are well calibrated, the outputs of the simulation are sensible and comply with the expected levels of losses and loadings of the assets.

4.2 CALCULATION OF THE COST WEIGHTS IN THE OBJECTIVE FUNCTION

As the reader may have noticed, the previous testing cases have been done without activating simulation options, now the weights of the associated cost of each term of the objective function has to be determined and after that, relevant simulation cases have to be performed to study how for example, distributed generation or different values of energy non-supplied change the operation of the grid. In order to determine the value of each associated cost, it is important to use the same approach and methodology, so that each term of the objective function has a properly well assigned weight.

Now, the determination and assumptions done to calculate each associated cost will be explained.

The first parameter is C_7 , it is measured in €/MVA and makes reference to the cost of power losses, or in other words, the annually investment and operation and maintenance costs of the marginal units of generation, which in Spain are typically the CCGTs. According to the paper "Papeles de Energía, Diciembre 2018", written by Tomás Gómez, Michel Rivier, José Pablo Chaves, Francisco Martin and Timo Gerres, this value is 65.625 €/MW, and it is the value that will be used in the model.

C_8 represents the associated cost of the energy losses, this value is measured in €/MWh and is the average cost of the energy in Spain for the year 2018, which is 53.825 €/MWh.

C_9 and C_{9R} represent the cost of load shedding in the grid and in the substation. The assumption made to calculate this value is that it will be the energy price cap in Spain, which is 180 €/MWh.

C_{10} and C_{10R} are the costs of curtailing generation in the grid and in the substation respectively. This cost is presumed to be the opportunity cost of the renewable generation in the time of the curtailment. In the case of solar PV this will depend on the hour of the day, but it will typically be lower than the average cost of the energy, as the daily prices are usually lower during the sun production hours. A value around 30 - 40 €/MWh seems reasonable.

DISTRIBUTION NETWORK ARCHETYPES FOR SIMULATING FLEXIBILITY PROVIDED BY DISTRIBUTED ENERGY RESOURCES

Finally, C_{11} represents the cost of load shifting, which should be lower than C_9 as the load will be supplied, however, you will have to compensate the demand so that they would have an incentive to move their consumption to the next hour. A value around 100 €/MWh seems reasonable, nevertheless, a sensibility analysis around this value will be performed.

The next table contains a summary of the values of the associated costs:

Parameter	Units	Value	Definition
C_7	€/MVA	65,625	Power investment marginal cost (cost of power losses)
C_8	€/MWh	53,825	Cost of energy losses
C_9	€/MWh	180	Cost of load shedding
C_{9R}	€/MWh	180	Cost of load connected to the subs. shedding
C_{10}	€/MWh	40	Cost of DER generation curtailment
C_{10R}	€/MWh	30	Cost of DER generation in the subs. curtailment
C_{11}	€/MWh	100	Cost of shifting load to the following period

Table 13. Associated costs for the objective function.

4.3 SIMULATION OF FLEXIBILITY OPTIONS & ANALYSIS OF THE RESULTS

Once the values of the associated costs are calculated, different scenarios can be simulated in GAMS to see if they trigger different flexibility options.

DEMAND INCREASE SIMULATION:

The most interesting cases to study the behaviour and operation of the network are the most unfavourable ones where the grid is more strained. Thus, the scenario of high demand shown in table 6 will be the base case scenario in this section and starting from there, different hypothesis of demand evolution, distributed generation deployment and demand flexibility will be studied.

**DISTRIBUTION NETWORK ARCHETYPES FOR SIMULATING FLEXIBILITY PROVIDED BY
DISTRIBUTED ENERGY RESOURCES**

Due to the electrification of the transport the electric demand is supposed to increase in the coming years, this together with the fact that the economic development and the population growth are strongly correlated with the electric demand may lead to scenarios of very high demand.

Now, three new simulations have been performed considering an increase in the demand of 10%, 20% and 30% from the high demand scenario. These simulations are trying to trigger any kind of load shedding either for reducing the cost of operation the grid or for keeping the grid within safety standards (maximum load rates in transformers and lines).

The demand used for the simulation will be assigned proportionally to the energy to each voltage level. The new demand scenarios are shown in the table below:

Voltage level	Base case [MW]	10% of increase [MW]	20% of increase [MW]	30% of increase [MW]
HV	1097,75	1207,52	1317,30	1427,07
MV	8703,79	9574,17	10444,55	11314,93
LV	20706,71	22777,39	24848,06	26918,73
Total	30508,26	33559,08	36609,91	39660,73

Table 14. Demand scenarios.

Again, as happened with the previous simulations, the input data of the model goes in per-surface units, making the input data of the model the following:

Voltage level	Base case [MW/km ²]	10% of increase [MW/km ²]	20% of increase [MW/km ²]	30% of increase [MW/km ²]
HV	0,00217470	0,00239217	0,00260964	0,00282711
MV	0,01724268	0,01896695	0,02069121	0,02241548
LV	0,04102110	0,04512321	0,04922532	0,05332743
Total	0,06043848	0,06648233	0,07252617	0,07857002

Table 15. Input demand data of the model.

Now, the obtained results for the three scenarios will be shown below:

First, the scenario of a 10% increase in the demand, where the obtained results were as expected, with a slight increase in the line and copper losses and an unvarying value for the iron

**DISTRIBUTION NETWORK ARCHETYPES FOR SIMULATING FLEXIBILITY PROVIDED BY
DISTRIBUTED ENERGY RESOURCES**

losses. Regarding the loading of the grid, the transformers in MV/LV were at 30% of their nominal capacity while the HV lines were at the 34% of their maximum allowed power flow.

The total losses represent a 9,53 % of the supplied demand, which is a considerable value, however, no load shedding is activated.

Voltage L.	Demand [MW]	D [MW]	E [MW]	Ψ [MW]	Γ [MW]	Φ [MW]
HV	1207,52	36760,69	34705,27	847,93	23,17	285,55
MV	9574,17	34396,55	24131,91	690,44		
LV	22777,38	23617,18	0	839,80	326,74	187,98
TOTAL	33559,08	-	-	2378,18	349,91	473,53
% Demand	100 %	-	-	7,08 %	1,04 %	1,41 %

Table 16. Results for an increase of the demand of 10%

Voltage L.	Demand [MW]	D [MW]	E [MW]	Ψ [MW]	Γ [MW]	Φ [MW]
HV	1317,30	40362,62	38023,11	1022,23	27,91	285,55
MV	10444,55	37709,63	24131,91	829,86		
LV	24848,05	25854,48	0	1006,43	392,72	187,98
TOTAL	36609,90	-	-	2858,53	420,63	473,53
% Demand	100 %	-	-	7,80 %	1,15 %	1,29 %

Table 17. Results for an increase of the demand of 20%

Table 17 shows the obtained results for an increase of the demand of 20% with respect to the high demand scenario. Line losses almost account for an 8% of the total demand and lines are loaded a 37 % of their nominal capacity.

Transformers in MV/LV are loaded a 32% and their losses are around 900 MW, which is a 2,44% of the demand.

As happened in the previous simulation scenario, there is no load shedding activated.

**DISTRIBUTION NETWORK ARCHETYPES FOR SIMULATING FLEXIBILITY PROVIDED BY
DISTRIBUTED ENERGY RESOURCES**

Finally, the last case of this section considers an increase of the demand of 30% and the obtained results are shown in the table below:

Voltage L.	Demand [MW]	D [MW]	E [MW]	Ψ [MW]	Γ [MW]	Φ [MW]
HV	1427,07	44022,64	31379,50	1216,02	33,21	285,55
MV	11314,93	41060,73	28761,92	983,92		
LV	26918,73	28108,28	0	1189,56	465,61	187,98
TOTAL	39660,73	-	-	3389,51	498,82	473,53
% Demand	100 %	-	-	8,54 %	1,25 %	1,19 %

Table 18. Results for an increase of 30%.

Despite having an 11% of the total energy to supplied lost in the iron and copper of the network there is yet no load shedding. This is because the marginal economic value of the load shedding is still higher than the possible savings obtained reducing the losses in a unit of energy supplied. Regarding the loading of the assets, these are still far from a dangerous situation, as the HV lines are at 44% of the maximum capacity and the MV/LV transformers are at the 40% of their nominal power.

The main conclusions that can be extracted from these results is the fact that the grid is over-dimensioned and can easily cope with big increases of the demand, however, despite handling these upsurges the losses reached are out of normal standards.

In order to activate load shedding it is necessary to either, reach the technical limit of the grid, thing that seems really difficult with believable demand values, or reach a point where an extra unit of demand destroys more value due losses if that demand is served rather than if it is dropped. Reaching this point with the current associated cost of losses and load shedding seems improbable and will need a demand out of sense in order to have unbearable levels of losses, which does not make any sense. However, it can be interesting to perform a sensitivity analysis around the associated costs, to study whether other costs of losses and of load shedding can generate unsupplied load for a constant demand.

SENSITIVITY ANALYSIS AROUND THE ASSOCIATED COST OF THE LOSSES AND LOAD SHEDDING:

In this analysis, the demand is going to be again, the demand used in the high demand scenario shown in table 5 and through a heuristic method, the associated costs of the energy losses and load shedding will vary to find the break-even point where load shedding occurs.

The first hypothesis to carry out this analysis is the fact that using the annual average price for the energy losses does not make sense in the case of simulating just a peak hour, where typically the prices are higher than the average. According to OMIE (Spanish market operator), at 9PM the 17th of January of 2018, the market price was 65,5 €/MWh.

Simulating the previous studied scenarios changing the cost of the energy losses from 53,8 €/MWh to 65,5 €/MWh but keeping the cost of load shedding to 180 €/MWh did not have any effect on the optimal dispatch and all the demand had been supplied.

Now, the associated cost of load shedding has to be reduced until there is load not supplied. Load shedding has started in the LV grid when the associated cost of this flexibility option (C_9 and C_{9R}) was 23,54 €/MWh. This value has been easy to obtain thanks to the information about the marginal variables that GAMS provides for each equation. This value of load shedding does not make any sense at all because it is very low, much lower than the cost of energy. According to Pedro Linares in his paper "The cost of electricity interruption in Spain. Are we sending the right signals" the value of lost load in Spain for household consumer (typical consumers connected to the LV network) is around 8,11 €/KWh, which is 8110 €/MWh, a value much bigger than the one obtained (23,54 €/MWh) and than the one used in the first simulations (180 €/MWh). The reason for this to happens is the fact that the price capped used in the Spanish market does not value properly the demand and this does not send the right signals to the generators, however, this is a topic out of the scope of this project.

The obtained results do not imply that load shedding will never happen in the Spanish system, nevertheless it is not something that may have an economic or operational value for the national distribution network. If any load shedding mechanism is to be applied in Spain it will be done by the system operator and probably, they would value it in a different way regarding technical or quality concerns to make it gainful in some extreme or scarce situations.

DISTRIBUTED GENERATION INCREASE IN THE MV/LV SUBSTATIONS

Now, a simulation introducing distributed generation will be performed. The objective is to study the impact that this generation may have in the grid and find around which levels of deployment the grid starts to suffer from technical issues.

Starting from the high demand scenario presented in table 5, different levels of DG generation will be connected in the MV/LV substation. The first scenario will consist on a generation of 10% of the LV demand of the system, then this percentage will increase to a 20% and to a 30%.

The input data for the simulation is shown in the next table:

Scenario	Generation [MW]	Generation [MW/km ²]
10 %	2070,67	0,004102109
20 %	4141,24	0,008204219
30 %	6212,01	0,012306328

Table 19. Generation input data

The associated costs of each term of the objective function are the ones shown in the table 13.

The results of the simulation are very interesting, losses have decreased, as the distributed generation has reduced the power flows in the lines. It is remarkable the fact that the energy entering the LV grid in the three cases is the same despite increasing the generation in the MV/LV substation. This is due to the fact that the energy entering the LV grid is already the minimum flow that can supply the demand and the losses in that voltage level, the remaining energy generated goes upward the grid reducing the flows in MV and HV.

It is important to take into account that the iron losses depend on physical characteristics of the transformers, that is why these are the same than in all the previous simulations (473,53 MW) and they account for a 1,55 % of the total demand.

The results for a generation of 10% of the LV demand is shown in the table below:

**DISTRIBUTION NETWORK ARCHETYPES FOR SIMULATING FLEXIBILITY PROVIDED BY
DISTRIBUTED ENERGY RESOURCES**

Voltage L.	Demand [MW]	D [MW]	E [MW]	Ψ [MW]	Γ [MW]	Φ [MW]	Gen [MW]
HV	1097,75	30937,28	29238,94	600,53	16,40	285,55	0
MV	8703,79	28937,03	19744,54	488,68			
LV	20706,71	21395,99	0	689,27	231,24	187,98	2070,67
TOTAL	30508,26	-	-	1778,49	247,64	473,53	2070,67
% Demand	100 %	-	-	5,82 %	0,81 %	1,55 %	6,7 %

Table 20. Results for generation 10% of the LV demand.

Table 21 shows the results for a generation of 20% of the LV demand.

Voltage L.	Demand [MW]	D [MW]	E [MW]	Ψ [MW]	Γ [MW]	Φ [MW]	Gen [MW]
HV	1097,75	28675,55	27061,81	515,93	14,08	285,55	0
MV	8703,79	26762,17	17640,41	417,95			
LV	20706,71	21395,99	0	689,27	197,82	187,98	4141,24
TOTAL	30508,26	-	-	1623,17	211,90	473,53	4141,24
% Demand	100 %	-	-	5,32 %	0,69 %	1,55 %	13,57 %

Table 21. Results for Generation 20% of the LV demand.

Finally, the obtained results for the last scenario are shown below:

**DISTRIBUTION NETWORK ARCHETYPES FOR SIMULATING FLEXIBILITY PROVIDED BY
DISTRIBUTED ENERGY RESOURCES**

Voltage L.	Demand [MW]	D [MW]	E [MW]	Ψ [MW]	Γ [MW]	Φ [MW]	Gen [MW]
HV	1097,75	26429,42	24893,37	438,30	11,96	285,55	0
MV	8703,79	24595,85	15539	353,04			
LV	20706,71	21395,99	0	689,27	167,08	187,98	6212,01
TOTAL	30508,26	-	-	1480,62	179,04	473,53	6212,01
% Demand	100 %	-	-	4,85 %	0,58 %	1,55 %	20,36 %

Table 22. Results for Generation 30 % of the LV demand.

It can be inferred from the outcomes of the simulations that distributed generation have numerous advantages regarding the operation of the grid, as the energy generated increases, the losses shrink considerably. This is because the energy flows through the network are reduced.

It is interesting the previously mentioned fact that D(LV) is the same despite the changes in distributed generation. This is explained because the energy flow in low voltage is already the optimal power flow that can go through that line to satisfy the demand while covering the losses.

The voltage levels and loading levels of the grid are better in these simulations than without distributed generation. This involves that generation curtailment with this over-dimensioned grid will not happen unless the generation reaches levels bigger than the demand.

SENSITIVITY ANALYSIS TRIGGERING FLEXIBILITY OPTIONS:

Probably, the most important analysis and the main contribution of the core model is the simulation of different flexibility options. Once the model and the inputs and outputs have been tested, it can be concluded that the network is over-dimensioned, and it will be impossible to activate load shedding or load shifting with sensible values of the associated costs of these options. However, a last sensibility analysis will be performed, where the grid is going to be modified in order to obtain a much less developed grid that may suffer from overloading and voltage drops, and the only solution to these will be to shed load or move it to the next hour.

**DISTRIBUTION NETWORK ARCHETYPES FOR SIMULATING FLEXIBILITY PROVIDED BY
DISTRIBUTED ENERGY RESOURCES**

Firstly, the nominal power of the transformers will be reduced a 50%, going from 50 MVA in HV/MV to 25 MVA, and from 250 KVA in MV/LV to 125 KVA. Secondly the resistance of the lines will be doubled, in order to increase the voltage drops and the line losses.

The input demand will also be modified, in order to have a very high load in the period t, and a much lower load in the period t+1, to see if shifting load from one period to another is profitable for the network.

The base case will consist on a 0,04 MW/km² demand in LV, which is 20.191 MW, in the time period t, meanwhile the next period, t+1, will entail a demand of 0,01 MW/km² in LV, which is 5047 MW.

The associated values for the different flexibility options are the ones shown in table 13.

The obtained results for the both time periods for this simulation are shown in the tables below:

Voltage L.	Demand [MW]	D [MW]	E [MW]	Ψ [MW]	Γ [MW]	Φ [MW]
HV	0	23896,68	23163,43	733,25	19,58	142,04
MV	0	23001,80	22327,66	674,13		
LV	20191,28	21902,89	0	1711,61	292,21	132,50
TOTAL	20191,28	-	-	3118,99	311,80	274,55
% Demand	100 %	-	-	15,44 %	1,54 %	1,39 %

Table 23. Obtained results for t1.

The obtained results are within the expected values of losses, as the iron losses have decreased due to the reduction of the nominal power of the transformers, on the other hand, line losses have grown to unusual values due to the increase of the resistance of the lines.

The load of the HV/MV transformer is around the 65% of its nominal capacity. Voltage drop is an 8,7% of the nominal voltage in LV, which is almost the allowed threshold (10%). No load shifting or load shedding has been activated in this hour.

**DISTRIBUTION NETWORK ARCHETYPES FOR SIMULATING FLEXIBILITY PROVIDED BY
DISTRIBUTED ENERGY RESOURCES**

The obtained results for the next time period which much lower demand are shown below:

Voltage L.	Demand [MW]	D [MW]	E [MW]	Ψ [MW]	Γ [MW]	Φ [MW]
HV	0	5508,53	5469,56	38,97	1,06	142,04
MV	0	5326,51	5290,36	36,14		
LV	5047,82	5142,16	0	94,34	15,68	132,50
TOTAL	5047,82	-	-	169,45	16,70	473,53
% Demand	100 %	-	-	3,35 %	0,33 %	5,44 %

Table 24. Results for t2.

As opposition of the results in t1, here, the losses are extremely low, this is explained because of the short demand. Obviously, all the grid assets are within technical standards.

Next figure shows the distribution of the demand in t1 and t2.

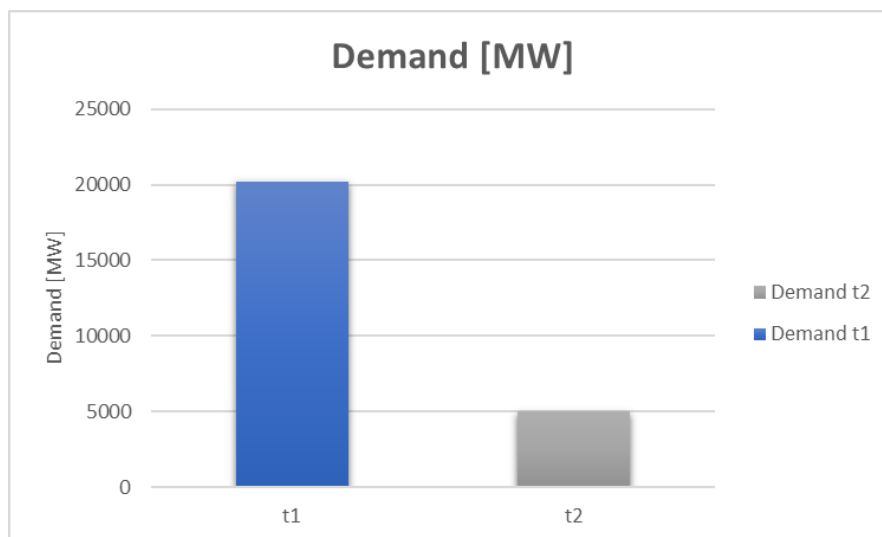

Figure 22. Demand in each period for 0,04 MW/km²

Now, the demand in t1 will increase from 0,04 MW/km² to 0,06 MW/km². The voltage drop limit is achieved and there will be load that cannot be supplied in that time period and will have to be shed or shifted.

In this scenario, load shifting has occurred, from a demand of 30286 MW, only 23219 MW have been supplied and 7311 MW have been shifted to the next period. T2 now has a demand of 12358 MW, the previous 5047 MW plus the shifted 7311 MW. The system could also shed this amount however, it is less costly for the grid to move it to the following time period with a cost

**DISTRIBUTION NETWORK ARCHETYPES FOR SIMULATING FLEXIBILITY PROVIDED BY
DISTRIBUTED ENERGY RESOURCES**

of 100 €/MWh and then pay the losses that this new load cause, rather than shedding it at a cost of 180 €/MWh.

Next figure showsh the distribution of the enrgy supplied in the two time periods.

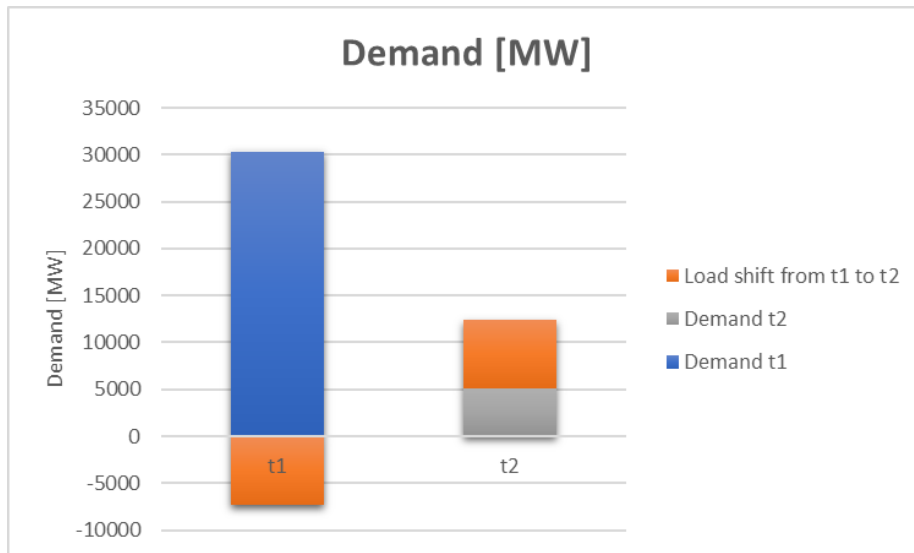

Figure 23. Energy supplied in each period.

Now, the demand will increase a little bit more till (0,07 MW/km²), to see if the cost of shifting plus the losses of the shift is not so preferable, and shedding is activated.

Again, only load shifting is activated, now 12359 MW are moved from t1, to t2, making the demand in t1 23219 MW and the demand in t2 17162 MW. These results are really interesting, as apart from protecting the grid, load shifting also flattens the load curve, with the associated benefits that these can have to the system as it is easier to control and operate a more predictable system without ramps.

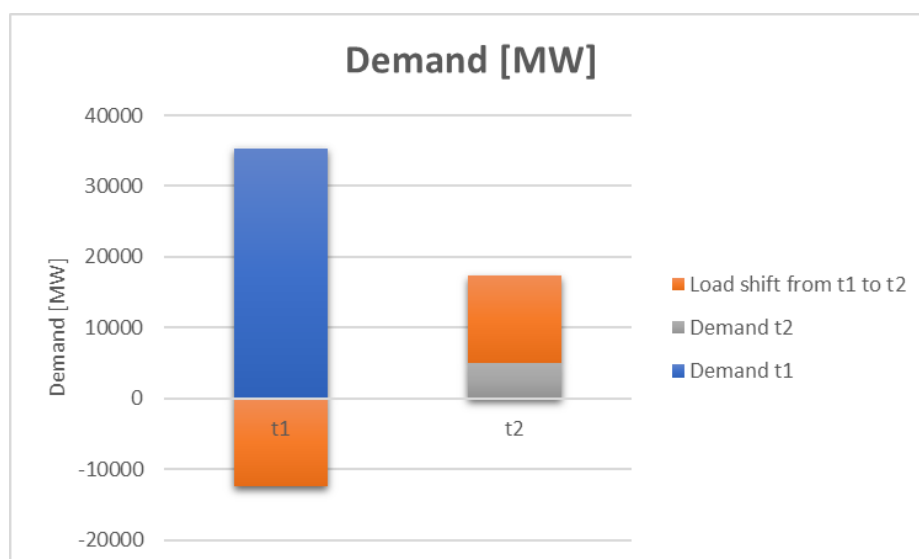

Figure 24. Energy supplied in each period

DISTRIBUTION NETWORK ARCHETYPES FOR SIMULATING FLEXIBILITY PROVIDED BY DISTRIBUTED ENERGY RESOURCES

Finally, a sensibility analysis will be performed in the cost of load shifting, in order to find the break-even point where both, load shedding and shifting are activated. The cost of load shedding will remain constant at a value of 180 €/MWh.

For an associated cost of load shifting of 159 €/MWh, load shedding appears. Now, 490 MW have been shed, while 11868 MW have moved from t1 to t2. Supplying a load of 23219 MW in the first period and 17162 MW in the second time period.

Figure 24 shows the distribution of the energy supplied in both periods.

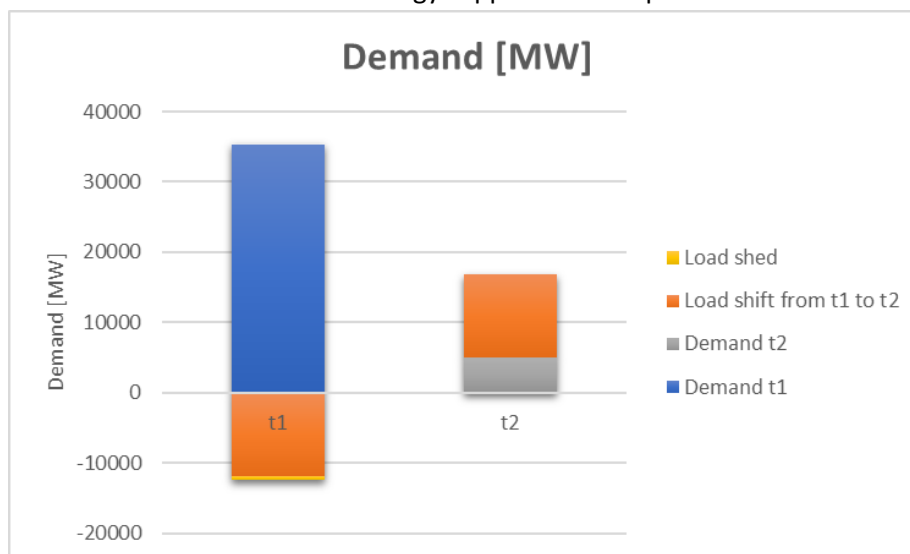

Figure 25. Energy supplied in the last scenario.

From the obtained results it can be concluded that flexibility on the demand has some benefits regarding the operation of the grid. It can maintain the grid within technical and quality standards, and it can also generate profits to other agents as it is the case of the system operator or generators that can continue generating in other hours with higher price thanks to load shifting. Nevertheless, it seems very important to identify the agents that will be load shifted or shed in order to assign them a correct associated cost of the option and obtain the optimal dispatch.

5. LIMITATIONS AND POSSIBLE IMPROVEMENTS OF THE MODEL

This section will entail the description of some limitations that have been observed in the Core model and some possible improvements that could improve the accuracy and robustness of the output solutions.

5.1 ELECTRICAL STORAGE

The first enhancement that the model should consider for next studies is the addition of storage. Electrical storage is something that unquestionably will play a very important role in the electrical system in the next years, it has interesting synergies with distributed generation and its deployment will affect enormously the operation of distribution networks. For this reason, this section will contain a set of equation in GAMS language to include electrical storage in the Core model.

Regarding the sets, the batteries equations and variables will depend on the time and the voltage level, and on a new set that must be created, containing the parameters of the battery.

The new inputs of the model are the parameters that are going to be the input data related to the characteristics of the batteries. These are introduced in the model as a table parameter which contains the following information.

```
TABLE DATSTORAGE (vl, storage)
      STElim      STPlim      Efficiency
HV      50        20         0.80
MV      20        10         0.75
LV      0.5       0.25      0.75
```

Figure 26. Table parameter of storage.

STElim and STPlim are the energy storage limit and the power storage limit respectively. This is, in other words, the maximum amount of energy that the battery can store during a period of time and the maximum allowed power for an instant that the battery can charge or discharge.

The outputs of the model are the decision variables that define the energy stored and the energy discharged in every period of time t , also a variable that expresses the level of storage needs to be defined, so that the battery is never charged more than what are feasible values.

**DISTRIBUTION NETWORK ARCHETYPES FOR SIMULATING FLEXIBILITY PROVIDED BY
DISTRIBUTED ENERGY RESOURCES**

The table shown below contains information about the needed variables:

Variable	Type	Dimension	Sets	Description
Esto	Positive	2	t,vl	Defines the energy stored in the battery
Edis	Positive	2	t,vl	Defines the energy discharged from the battery
STlevel	Positive	2	t,vl	Defines the level of storage of the battery

Table 25. Variables for the storage modelling.

Now, the set of equations that rule the behavior of the battery will be defined, after, how the installations of batteries would be included in some of the Core model equations.

The first equation defines the storage level of the battery:

$$STlevel(t, vl) = STlevel(t - 1, vl) + (Esto(t, vl) \times \eta) - Edis(t, vl)$$

Which has to be always equal or lower than the maximum energy storage limit, as shown in the following equation:

$$STlevel(t, vl) \leq STElim$$

The energy stored and discharged in every time period has to be lower or equal to the maximum storage power limit. This is defined in the next two equations:

$$Esto(t, vl) \leq STPlim$$

$$Edis(t, vl) \leq STPlim$$

The energy discharged cannot be bigger than the energy stored in the battery, this can be solved applying the next equation:

$$Edis(t, vl) \leq STlevel(t, vl)$$

The equations above can be added in the core model without changing anything, however, the effect of the storage has to be included now in the energy balance equation and in the objective function.

The effect of the battery in the energy balance equation will be introduced by the addition of the energy stored and discharged in the net load equation. These variables are shown in the next equation in red.

$$NC(t, vl) = [DATVLT(vl, dem', t) - AC(t, vl) - CS(t, vl)] \\ - [DATVLT(vl, gen', t) - AC(t, vl)] - [Edis(t, vl) - Esto(t, vl)]$$

Regarding the associated cost of storing and discharging energy from the battery, this will be the cost of the energy. The economic value is created when the difference between the costs of storing is lower than the cost of discharging.

The cost of operating the battery will then be the energy stored times the price of the energy in that moment t, minus the energy discharged times the price of the energy in that moment t+n. This can be included in the objective function in the following way:

$$COST = C_7 \times \max(t, \sum_{vl} \Psi(t, vl) + \sum_{vl} \Gamma(t, vl, vl + 1) + \sum_{vl} \Phi(vl, vl + 1)) \\ + C_8 \times \sum_t \left[\sum_{vl} \Psi(t, vl) + \sum_{vl} \Gamma(t, vl, vl + 1) + \sum_{vl} \Phi(vl, vl + 1) \right] \\ + C_9 \times \sum_t \sum_{vl} CS(t, vl) + C_{9R} \times \sum_t \sum_{vl} SCS(t, vl, vl + 1) \\ + C_{10} \times \sum_t \sum_{vl} AG(t, vl) + C_{10R} \times \sum_t \sum_{vl} SAG(t, vl, vl + 1) \\ + C_{11} \times \sum_t \sum_{vl} AC(t, vl) + C_{11R} \times \sum_t \sum_{vl} SAC(t, vl, vl + 1) \\ + \sum_t C_{12}(t) \times Esto(t, vl) - \sum_t C_{12}(t) \times Edis(t, vl)$$

C_{12} is now a parameter that depends on the time, and gets a different value for each time period. This value should represent in every moment the value of the energy, something which should also be used to substitute C_8 as it is more sensitive to evaluate the cost of the losses with the hourly cost of the energy.

5.2 TIME-DEPENDANT PRICE

This is a limitation found in the model, and it is the fact that considering an average price (yearly, seasonally or daily) for the energy price (used in the energy losses) is a bit distorting as there are big spreads in the energy price in a whole day. The price during valley hours with many renewable generation are much lower than the prices during peak hours with almost no renewable generation and this difference may affect the operation of the network as the losses, the effect of the batteries and load shifting can have very diverse associated costs for a same day.

The proposed solution for this issue is to consider an hourly profile of prices (idea introduced mathematically in the objective function in the storage modelling) so that the assessment of the energy price is more truthful.

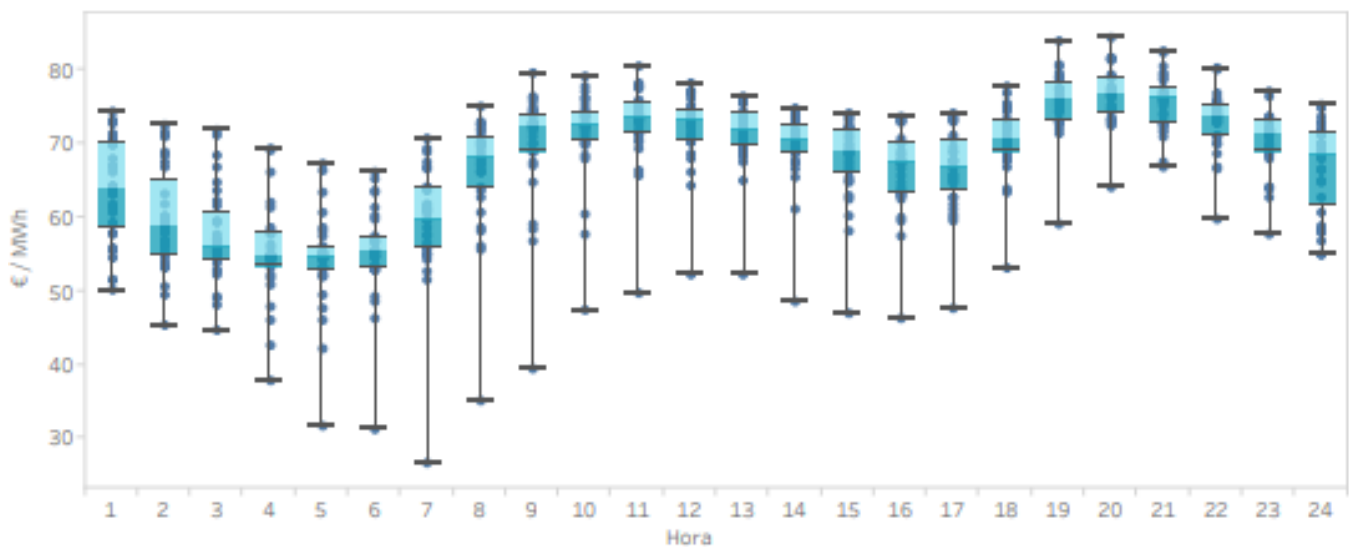

Figure 27. Hourly variation of prices in January, Spain.

Figure 22 shows the hourly distribution of the electricity price for January of this year. It can be easily observed that in average the spread reaches almost 20 €/MWh from valley hours to peak hours, and these are economic signals not being considered with the approach used in the model at the moment.

5.3 LOCATIONAL DISTURBANCE

It has been observed performing some simulations that there may be an issue related to the fact that no locational information is considered in the model.

If an amount of energy generated by DER is included in a grid voltage level, this generation will be netted with the demand in the same voltage level, reducing the demand (supposing that the demand is bigger than the generation). This makes sense except for the fact that this distributed generation may be located in a residential place in an urban area, however, part of the energy generated will be 'consumed' by other demand connected at the same voltage level but maybe located very far away from the generation and with possibly other distribution grid architecture. Using the example of Spain, it can be that distributed generation installed in the LV network of Madrid can reduce the demand and therefore the associated losses of the LV rural areas of Galicia. It is doubtless that this issue may distort the obtained results regarding the operation of the network, nonetheless, quantifying the error that this circumstance produces seems very difficult and maybe it is pointless.

The proposed solution in this master thesis is creating few clusters of grid characteristics, for example, one for a very high density populated urban network, another for a medium density population urban network and lastly, for one low density populated rural network. Then, the cost of the operation of each cluster will be solved using the same approach that in the core model. Finally, a weight will be assigned to the results of the clusters to determine the total cost of the grid operation. The weights should be determined experimentally, for example, it can be 50%, 35% and 15% for the very high density, high density and low density clusters.

6. CONCLUSIONS

This section will entail the main conclusions than can be extracted from the elaboration of this master thesis.

Firstly, it has to be said that the programming of the core model in GAMS has been very challenging, furthermore, understanding the concept that a two nodes grid with all the inputs in per-surface units could represent accurately a grid with millions of kilometres of lines was also very intricate.

The model satisfies its main purposes, as it gives an idea of the operation of the grid under certain circumstances, and the simulations are performed just in seconds without a great computational effort, however, the accuracy of these results is undetermined and it is difficult to know exactly how truthful are the representations of the grid. The solutions should be checked with the solutions obtained with a traditional OPF programme for the same scenarios and see by this testing if the Core Model is precise enough to help in the decision-making process of DSOs.

It also can be concluded with certain security that the distribution network in Spain is over-dimensioned in average, as the maximum level of loading obtained has been 44% in the HV lines for a demand 30% bigger than the highest demand in the whole 2018. These results do not depend on the model at all, as the definition of the nominal capacity of the grid and the levels of demand used in the simulations where provided by the IIT, and all the data was gathered from justified assumptions or trustful sources.

It was explained in the section 5.3 but despite reaching a maximum loading level of 44% it cannot be assured that there are not lines or transformers working over their limits. This is caused because considering for the simulations a such immense grid can ignore the results out of the average and say that the lines are at 44% of their capacity when one line is over 100% and other 20 lines are at 40% of their nominal capacity.

It would have been interesting to perform some simulations during a time window to see the behaviour of energy storage, however, in a beginning the model was not well designed for this aim, as the energy storage was not considered (added in the section 5.1).

It has also been observed that distributed generation has more benefits than drawbacks and that its implementation will improve the operation of the grid reducing the energy flows

DISTRIBUTION NETWORK ARCHETYPES FOR SIMULATING FLEXIBILITY PROVIDED BY DISTRIBUTED ENERGY RESOURCES

travelling long distances and therefore, reducing the energy losses. Apart from being renewable sources that do not emit greenhouse gasses and reduce the international energy dependency.

Regarding load shedding, this is a plausible option when the system is about to reach its technical limits, nevertheless, the considered grid was too over-dimensioned to activate the load shedding for this purpose. The other remarkable conclusion about load shedding is the idea that it can only be applied by the system operator under extreme circumstances as the associated cost of this option is very high and it is impossible in Spain to reach that levels of price of the energy, as the VOLL for households may be around 8000 €/MWh.

Finally, one of the most important conclusions that has been obtained through modifying the data of the grid, is the fact that when the network is strained, load shedding and load shifting can help DSOs operating the grid within technical limits. Also, the benefits of load shifting go beyond DSOs influence, as many other agents will benefit from having a more predictable and stable system, with less spread between prices. The cost of load shifting has to be evaluated carefully as the sensibility of the effect of load shifting will vary enormously between some agents as some will never accept to move their load if they are in the middle of an industrial process, while others may be delighted to reduce their load in exchange of economic benefits.

7. REFERENCES

- [1]. European Commission, 2009. COM (2009) 519, Communication from the Commission to the Council, the European Parliament, the Economic and Social Committee and the Committee of Regions, Investing in the Development of Low Carbon Technologies (SET-Plan), 7 October 2009 and Respective Accompanying Working Documents.
- [2]. Pérez-Arriaga, I. (2013). "Regulation of the Power Sector". Gómez, T. (2013). Chapter 5. "Electricity Distribution" pp (199-250).
- [3]. Eurelectric (2013). "Power Distribution in Europe".
- [4]. Pérez-Arriaga, I. (2013). "Regulation of the Power Sector". Laloux, D. et al. (2013). Chapter 1. "Electricity Distribution" pp (21-27).
- [5]. Lopes Ferreira, H. Costescu, A. L'Abbate, A. (2011). "Distributed generation and distribution market diversity in Europe" Energy Policy.
- [6]. L'Abbate, A., Fulli, G., Starr, F., Peteves, S., 2007. Distributed Power Generation in Europe: technical issues for further integration, JRC Scientific and Technical Report.
- [7]. European Parliament and Council, 2009a. Directive 2009/28/EC of 23 April 2009, on the promotion of the use of energy from renewable sources and amending and subsequently repealing Directives 2001/77/EC and 2003/30/EC.
- [8]. TRACTEBEL. (2018). "Functional specifications of Distribution Core Model"
- [9]. Tomás Gómez (2018). "Señales de precio a la inversión en un mercado eléctrico con elevada penetración de renovables".
- [10]. Pedro Linares (2008), "The costs of electricity interruptions in Spain. Are we sending the right signals?"
- [11]. Claire Bergaentzlé (2013). "Demand side management in an integrated electricity market: what are the impacts on generation and environmental concerns ?"
- [12]. Stefan Ambec (2019). "The value of lost load".
- [13]. OMIE (2019). "Precio horario del mercado diario".
- [14]. Schneider Electric (2014). "Transformer efficiency".
- [15]. Red eléctrica de España (2019). "Generación y consumo a tiempo real".
- [16]. CEER (2018). "The role of DSOs in Flexibility".
- [17]. Capgemini (2018). " The DSO model: the emerging challenges with the DSO role":