

Received June 2, 2019, accepted July 2, 2019, date of publication July 11, 2019, date of current version September 4, 2019.

Digital Object Identifier 10.1109/ACCESS.2019.2928391

# The Role of Power Line Communications in the Smart Grid Revisited: Applications, Challenges, and Research Initiatives

GREGORIO LÓPEZ<sup>1</sup>, (Member, IEEE), JAVIER MATANZA<sup>1</sup>,  
DAVID DE LA VEGA<sup>2</sup>, (Member, IEEE), MARTA CASTRO<sup>3</sup>, AMAIA ARRINDA<sup>2</sup>,  
JOSÉ IGNACIO MORENO<sup>4,5</sup>, (Senior Member, IEEE), AND ALBERTO SENDIN<sup>1</sup>

<sup>1</sup>ETSI ICAI, Universidad Pontificia Comillas, 28015 Madrid, Spain

<sup>2</sup>Bilbao Engineering College, University of the Basque Country, 48013 Bilbao, Spain

<sup>3</sup>Tecnalia. Parque Científico y Tecnológico de Bizkaia, 48160 Derio, Spain

<sup>4</sup>Department of Telematics Engineering, Universidad Politécnica de Madrid, 28040 Madrid, Spain

<sup>5</sup>Department of Telematics Engineering, Universidad Carlos III de Madrid, 28911 Leganés, Spain

Corresponding author: Gregorio López (glopez@comillas.edu)

This work was supported in part by the Basque Government under Grants IT1234-19 and Elkartek KK-2018/00037, by the Spanish Government under Grant RTI2018-099162-B-I00 (MCIU/AEI/FEDER-UE), by the Research Project MAGOS under Grant TEC2017-84197-C4-1-R and by the network CITIES funded by CYTED.

**ABSTRACT** Power line communications (PLC) have been an active research area for many years and it is still the case, mainly because they present economic and technical natural advantages for a wide range of applications using the existing electrical grid as transmission medium. In this paper, the authors provide an update on PLC technologies and their applications in Smart Grids, the main challenges they are currently facing, how they can be addressed, and the current research initiatives.

**INDEX TERMS** Communications networks, communications technologies, power line communications, smart grids.

## I. INTRODUCTION

Information and Communication Technologies (ICT) are a key aspect in Smart Grids (SG) applications, in general, and in Smart Metering and Advanced Metering Infrastructures (AMI) [1]–[3], in particular. Power Line Communications (PLC) present some natural advantages that make them appropriate for this kind of applications, such as the advantage of using the already deployed electrical grid as the communication medium. However, since such cables were designed to transmit power, instead of data, they are usually a harsh communication medium, suffering from frequency fading, variation of the properties of the propagation medium caused by the continuous connection and disconnection of different loads, Electro Magnetic Interference (EMI), and, above all, a variety of noises and non-intentional emissions (NIE) generated by regular appliances, such as TVs or boilers, and by novel equipment, such as Distributed Generation (DG) devices, Electric Vehicles (EVs) or battery chargers [4], [5] (the so-called, Grid Edge Technologies [6]). As a result, PLC has been an active research area in the last years

The associate editor coordinating the review of this manuscript and approving it for publication was Jian Song.

and it is still an attractive and live research topic, as it is shown in some recent special issues and surveys on the topic published in highly recognized research journals [7]–[9].

In this paper, the authors, based on their applied research experience on different topics related to PLC during the last years, aim to provide their view on the current and foreseen role of PLC in the SGs, as well as on the main challenges and research initiatives in PLC.

The article is organized as follows. Section II provides an overview and classification of the main PLC technologies available in the market and section III presents both recently developed and future applications. Section IV presents the main challenges that PLC will face in the coming years and section V reviews some relevant research initiatives to address and overcome such challenges. Finally, section VI highlights the main conclusions of this review.

## II. OVERVIEW OF POWER LINE COMMUNICATION TECHNOLOGIES

The bandwidth is the most common criterion used to classify the different PLC technologies into three different categories [10]: Ultra Narrowband PLC (UNB-PLC), Narrowband PLC (NB-PLC), and Broadband PLC (BPL).

UNB-PLC refers to systems using very narrow bandwidth for data transmission in frequencies below 3 kHz. Most of these technologies transmit the data when the electrical signal crosses zero, in order not to be affected by the high amplitude of mains and harmonics. Due to the extremely low frequency range used by these technologies, they are less affected by transmission losses, and therefore, they can reach long distances and even go beyond transformers without repeaters. Since the signal goes beyond transformers, UNB-PLC technologies can be used both in Medium Voltage (MV) and Low Voltage (LV) sections. The main drawback is the limitation of conveying very low data rates (a few hundreds of bps).

The X10 technology [11] represents a well-known example of UNB-PLC technology which has been used in home automation since the 1970s. Another example of this kind of PLC technologies is Aclara Two-Way Automatic Communications System (Aclara TWACS) [12], [13], which represents the leading UNB-PLC technology for AMI. TWACS systems have been widely deployed for remote meter reading and direct load control applications in North America (e.g., Florida Power & Light has a long and successful deployment of millions of TWACS-enabled meters and as many as one million residential load control devices, supporting one of the largest Demand Response programs in the world) [14]. Nevertheless, the low data rate of this technology is a limiting factor for its use in more advanced and challenging applications.

NB-PLC refers to systems that work with medium data rates in frequencies between 3 and 500 kHz. This frequency range includes the European CENELEC bands (3 - 148.5 kHz), the US FCC band (10 - 490 kHz), the Japanese ARIB band (10 - 450 kHz), and the Chinese band between 3 kHz and 500 kHz. This category can be in turn divided into Low Data Rate (LDR) and High Data Rate (HDR) technologies.

LDR NB-PLC technologies are based on single carrier modulations conveying data rates of a few kbps. Within this group, it is worthwhile to highlight the following technologies due to their importance in current AMI deployments:

- Open Smart Grid Protocol (OSGP) [15], initially promoted by Echelon. The PHY and MAC layers have been standardized by the IEC. This protocol presents the highest penetration rates in the Nordic countries and Russia [16].
- Meters and More [17] is a non-profit international association led by the ENEL group. The association aims at defining and promoting the communication protocol, which has also been standardized by the IEC. The solution consists of a narrowband Binary Phase Shift Keying (BPSK) modulation over PLC, able to achieve up to 4.8 kbps. Encryption and authentication are also implemented via a 128-bit Advanced Encryption Standard (AES) key. One of the strongest points of Meters and More is that the Distribution System Operator (DSO) ENEL deployed this technology in the 100% of the Smart Meters (SMs) in Italy a decade ago.

The DSO Endesa has also deployed this technology in Spain, following the massive deployment mandated by the Royal Decree 1634/2006.

HDR NB-PLC technologies are based on multicarrier modulations and transmit data rates of hundreds of kbps, which can reach up to 1 Mbps in the frequency range up to 500 kHz. These technologies have been developed in the last decade and are one of the preferred solutions for the last-mile of smart metering applications. This group consists of proposals initially promoted by industrial alliances, later standardized (PRIME and G3-PLC), and actually being deployed; and proposals promoted by standardization bodies (ITU-T G.hnem and IEEE 1901.2), which have not had commercial success:

- PRIME specification is promoted by the PRIME Alliance [18] led by the Spanish DSO Iberdrola. This specification became later a standard under the reference ITU-T G.9904 [19]. PRIME specification defines the Physical (PHY), Data Link (DL) and Convergence (CL) layers. The PHY layer is based on Orthogonal Frequency-Division Multiplexing (OFDM), supporting different coding schemes, which yield a wide range of data rates with different levels of robustness. There are two versions of PRIME: PRIME v1.3.6, operating in the CENELEC A band (specifically, from 41 to 89 kHz) and widely deployed in some European countries, and the more recent PRIME v1.4, designed for frequencies up to 500 kHz, for its use in the American and Asia Pacific markets. Table 1 compares specifications of both versions. PRIME is currently being deployed in Spain, Portugal, Poland, and Brazil.
- G3-PLC is a NB-PLC transmission technology developed by the G3-PLC Alliance [20], led by the French DSO Enedis (formerly ERDF) and Maxim. It also became a standard under the reference ITU-T G.9903 [21]. As PRIME, it uses OFDM to allow a more efficient use of the spectrum; in contrast, G3-PLC is focused on increasing the robustness of the communication by means of the outer layer of the channel coding. This improvement in the performance leads to lower transmission speeds (up to 34 kbps in CENELEC A band). This can be observed in the comparison between G3-PLC and PRIME v1.3.6 in CENELEC A band, shown in Table 2. The G3-PLC technology can be used in frequencies up to 500 kHz, targeting the American and Asia Pacific markets
- ITU-T G.hnem specification is described in the ITU-T G.9902 recommendation for NB-PLC below 500 kHz [22]. As a matter of fact, it represents an effort from the ITU-T to homogenize the available NB-PLC technologies (especially, PRIME and G3-PLC). The design of the PHY transceiver defines several configurations to be used depending on the band available for communication (i.e., CENELEC A/B/C/D or FCC). In any case, all configurations use OFDM-based modulations with different numbers of carriers and pilots. In terms of

**TABLE 1. Comparison between PRIME v1.3.6. and PRIME v1.4.**

Layer	Feature	PRIME v1.3.6	PRIME v1.4
PHY	Modulation	OFDM	OFDM
	Frequency band	CENELEC A	FCC
	Data rate	Up to 130 kbps	Up to 1Mbps
	Forward Error Correction	Convolutional coding + Interleaving (optional)	Convolutional coding + Interleaving (optional)
	Robust mode	No	Yes (repetition coder)
DLL	Logical topology	Tree (using switches)	Tree (using switches)
	Network formation	Beacon discovery, automatic promotion	Beacon discovery (longer), automatic promotion
	Multi-hop routing	Yes	Yes
	Keep-alive monitoring	Yes	Yes (with link quality info)
	Connection management	Yes	Yes
	Medium Access Control	CSMA/CA	CSMA/CA
	Automatic Repeat reQuest	Selective ARQ end-to-end	Selective ARQ end-to-end
	Security	128-AES in CBC	128-AES in CBC
Aggregation	Optional in switch node	Optional in switch node	

**TABLE 2. Physical speed comparison (in kbps) between G3-PLC and PRIME v1.3.6 [22].**

FEC Mode	G3-PLC		PRIME	
	Conv. + RS + RC	Conv. + RC	Conv. ON	Conv. OFF
DBPSK	3.2	15.8	21.4	42.9
DQPSK	-	34	42.9	85.7
D8PSK	-	-	64.3	128.6

robustness, ITU-T G.hnem outperforms even G3-PLC, since it includes several interleaver structures specially designed to mitigate AC-synchronous impulsive noise. However, ITU-T G.hnem is computationally heavier than PRIME and G3-PLC.

- The IEEE 1901.2 is the proposal made by the IEEE in order to design a NB-PLC transceiver. Due to its late appearance, some parts are based on both PRIME and G3-PLC specifications. In addition, it provides mechanisms for the coexistence with them, by dynamically changing the frequencies used as data subcarriers. IEEE P1901.2 is based on OFDM in the 10-490 kHz frequency range, but it allows the transceiver to be configured with different parameters in order to adequate the transmitted signal to the corresponding frequency band (i.e., CENELEC or FCC).

Table 3 shows a comparison of the NB-PLC technologies most deployed on the field.

CX1 [11] is a HDR NB-PLC technology promoted by Siemens, although the lower layers are being addressed by the IEC. CX1 uses an Adaptive Multi-Carrier Spread Spectrum (AMC-SS) modulation based on Frequency Hopping. Based on [16], this technology is mainly deployed in Austria, although currently there is few information available.

The DLMS/COSEM [23], [24] model, standardized by the IEC 62056 set of standards, was selected by the above-mentioned NB-PLC technologies, when used for metering purposes. COSEM is a data model that functionally describes any kind of meter by means of a set of interface classes. Thus, all the functionalities of a meter are mapped onto

objects, which are specific instances of such interface classes. These objects are defined by a set of attributes and are univocally identified by the so-called Object Identification System (OBIS) codes. DLMS is the protocol which specifies the rules to access and modify (i.e., get/set) the attributes of the set of objects that defines the functionality of a given meter.

Finally, BPL encompasses a large variety of systems that aim at high data rates, operating in frequencies from 1 MHz up to 250 MHz. BPL can be used in LV and MV sections, typically enabling home network multimedia communications, in the former case, and distribution automation/telecontrol and even AMI, in the latter case. Apart from the industrial solutions based on OPERA specification, the main standards providing specifications for BPL communications that could be used over MV and LV distribution infrastructures are IEEE 1901 (notably the Access System specification) and ITU-T G.9960 (also known as ITU-T G.hn) [25].

The IEEE 1901 standard considers two different PHY/MAC specifications: one based on Fast Fourier Transform (FFT) and another one based on the use of Wavelets. Furthermore, it describes both indoor broadband communications over LV lines and broadband communications over MV lines [26], and even over telephone wiring and coaxial cables [27]. The ITU-T G.hn standard features very similar technical specifications compared to IEEE 1901, allowing equipment interoperability.

Another well-known BPL technology is HomePlug AV, specified by the industry association HomePlug Alliance. HomePlug AV-compliant products are fully interoperable with IEEE 1901-compliant products (as a matter of fact, HomePlug technology was included in the baseline IEEE 1901 standard in 2008). Standing out among the multiple specifications of the HomePlug Alliance is HomePlug Green PHY, which targets applications related to the Internet of Things (IoT), such as home automation and control, home energy management systems, or even EV charging, providing lower consumption, cost, and data rates, if compared to HomePlug AV.

**TABLE 3. Summary and comparison of the NB-PLC technologies most deployed on the field.**

Category	Technology	Promoter	Standard	Band	PHY max Data Rate (kbps)	Million of compliant smart meters
LDR	OSGP	Echelon	IEC 14908.1	CENELEC A (35-91 kHz)	3.6	4 [15]
	Meters&More	ENEL	CLC TS 50568-4	CENELEC A (35-91 kHz)	9.6	Over 40 [17]
HDR	PRIME	PRIME Alliance (Iberdrola)	ITU-T G.9904	CENELEC A (ARIB and FCC)	128.6 (v1.3.6) 1,000 (v1.4)	Over 20 [18]
	G3-PLC	G3 Alliance (EDF)	ITU-T G.9903	CENELEC A (ARIB and FCC)	34	Over 20 [20]

**TABLE 4. Comparison between BPL technologies.**

Tech./Std.	OPERA	IEEE1901	ITU-T G.hn	HomePlug AV	IEEE 1901.1-2018 (SGPLC)	IEEE P1901.3 (IoTPLC)
Promoter	IBERDROLA DS2	IEEE	ITU-T	HomePlug	Huawei	Panasonic
Band	2 - 7 MHz (mode 1) 8 - 18 MHz (mode 2)	2 - 60 MHz	2 - 100 MHz	2 - 30 MHz	<12 MHz	<100 MHz
Modulation	OFDM	FFT-OFDM Wavelet-OFDM	FFT-OFDM	OFDM	FFT-OFDM Wavelet-OFDM	Wavelet-OFDM
PHY max data rate	Tens Mbps	500 Mbps	2 Gbps	200 Mbps	Tens Mbps	500 Mbps 1 Gbps (coaxial)
Channel Access	TDMA (centralized)/ CSMA-CA	TDMA/ CSMA-CA	TDMA/ CSMA-CA	TDMA/ CSMA-CA	TDMA/ CSMA-CA	TDMA/ CSMA-CA

Two recent initiatives within IEEE are worthwhile mentioning. First, the IEEE Std 1901.1-2018, Standard for Medium Frequency Power Line Communications for SG Applications [28], is a new IEEE standard strongly promoted by Huawei, which defines physical (PHY) and media access control (MAC) layers of the medium frequency band (less than 12 MHz). It is an OFDM-based BPL communication technology, claiming to cover SG applications, including security and coexistence with other technologies based on IEEE 1901-2010. The ambition of this standard is to achieve an extended communication range with medium speeds, in comparison with other existing PLC technologies. Second, IEEE 1901a-2019 [29] has been issued as a draft standard for BPL networks, amending the PHY and MAC layer specifications in IEEE 1901-2010, claiming enhancements for IoT applications. This initiative started as P1901.3, strongly promoted by Panasonic, and it implements some new functions based on the Wavelet OFDM technology, already included in the IEEE 1901-2010 [30]. The two initiatives broadly overlap, but are assumed to coexist using existing IEEE 1901-2010 Inter-System Protocol (ISP).

Table 4 summarizes and compares BPL technologies.

### III. APPLICATIONS OF POWER LINE COMMUNICATIONS IN SMART GRIDS

Applications based on PLC highly depend on the particularities of the market and the regulation of each country. These factors may constrain the functionalities and the deployment of the SGs applications based on PLC around the world. Despite different classifications may exist, the PLC market can be segmented into three broad types of applications: SGs, indoor networking, and long-distance applications

(long-haul) [31]. This article focuses on PLC for SG applications, including also some references to Smart Cities deployments due to its close relationship [32]. Applications of PLC in SGs are mainly related to the electricity distribution and communication between consumers and the utility. Current examples of these applications are AMI systems, EV charging systems, Telecontrol applications, Smart Cities, and DG systems [33]. For these applications of PLC in SGs, both NB-PLC and BPL technologies, described in the section 2, are used. Some other relevant applications of PLC for SGs are those related to grid topology connectivity, cable health monitoring and fault location, as covered by literature [34]–[40]. NB-PLC and BPL technologies provide real-time data to the devices connected to the grid, enabling an easy understanding of the network, as well as an efficient management of events and failures [41].

In Figure 1, a representative example of a PLC solution for SG is shown. NB-PLC and BPL solutions can be implemented for the management of MV substations, EVs and EV charging points, Ring-Main Units (RMUs) and Data Concentrators (DC), Smart Homes and Distributed Energy Resources (DER). In this case, PLC can be used in both MV and LV sections [42].

The major driver for the deployment of PLC market is the increase of SG installations. The major deployments of PLC are located in the European market. However, the implementation of systems based on PLC technology have recently started also in Asia and America. Nowadays, hundreds of millions of PLC devices are deployed all over the world. The objective of achieving secure and reliable communications with utility control centers is a challenge. The main problems for that are caused by noises generated by electrical devices,

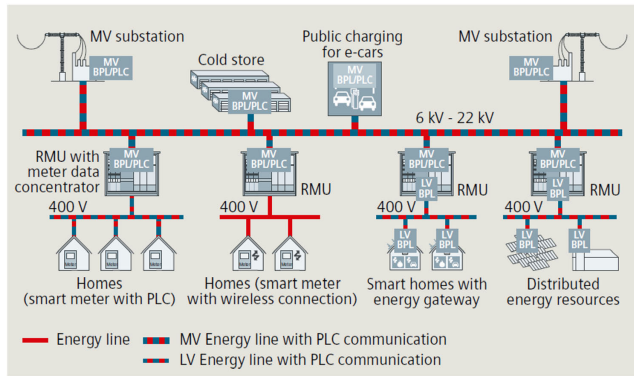

FIGURE 1. Power line carrier communication solutions for distribution networks [41].

which may affect the proper performance of the communications. In AMI systems, in particular, the electrical noises can block the communication between the meters and the head-end systems in the worst case, and produce datagram losses [4], [5], [43], [44].

Other factors that may or have slowed down the deployment of the PLC technology are security issues related to the regulation in different countries, interoperability of different PLC solutions, and network topology of each country (e.g., a meshed electricity network, neutral secondary substations connectivity and others, could challenge the deployment of PLC in SG if not properly engineered).

**A. ADVANCED METERING INFRASTRUCTURE**

AMI systems enable, first, the measurement of real, detailed, time-based information; then, the collection of all these data; and last, the transmission of such information to specific equipment in the network, as well as the transmission of commands on the opposite direction [45]. Therefore, an AMI system is capable of both collecting and managing data from SMs and sending them commands by means of two-way communications. The utilities use the data to provide consumers with new services and products to ensure the minimum quality of service defined in each country regulation, and eventually, customer empowerment through its involvement as a stakeholder of the electricity system.

As Figure 2 shows, AMI systems are composed of meter devices, Data Concentrators (DC) and a Meter Data Management System (MDMS) [45], [47]. MDMS acquire the data from the DCs (centralized or distributed - see the different possible architectures in [48]) and organize the data in a database. The meters, usually located close to end-user premises, collect metering data to be sent towards the DC. The data from different meters are collected in the DC and sent to the MDMS [46]. The place where the data concentrators are deployed may vary depending on the features of the power distribution infrastructure (e.g., number of SMs per Secondary Substation (SS), length of the LV cables, number of SS per primary substation, etc.). For instance, in Europe (and China) such DCs are typically located at the SS since

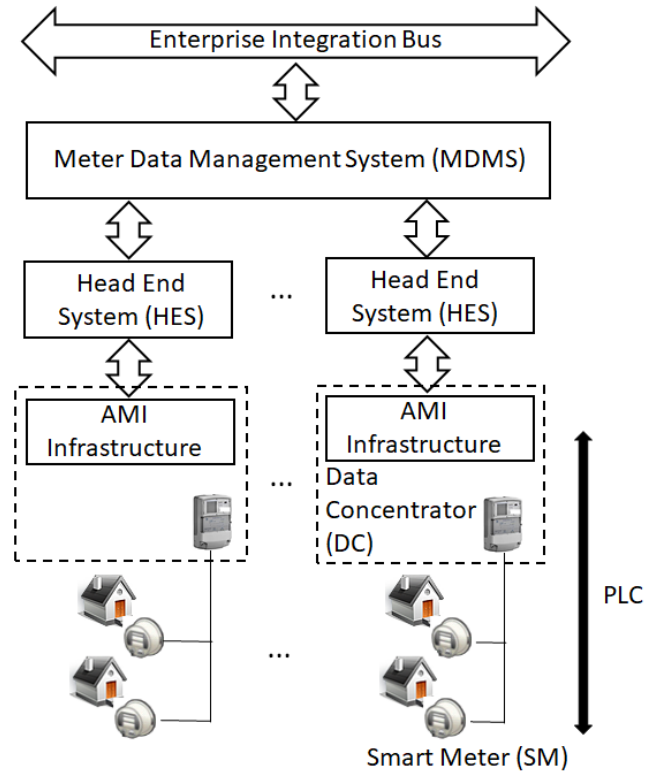

FIGURE 2. Advanced (or Smart) Metering architecture [46].

LV cables are long and power distribution grids are reasonably dense; whereas in the US (and Japan) they are located upwards in the power distribution hierarchy because the LV cables are shorter and less populated [49], [50].

NB-PLC is one of the most extended solutions for AMI purposes in Europe. It is mainly used for the communication between the SMs and the DCs. Although BPL can be also used in this communication segment [51], this technology may be used between the DC and the Head End System over the MV or Field Area Networks (FAN) for AMI and tele-control purposes [52], [53].

In Figure 3, a detailed comparison among different technologies used in AMI systems is shown. The compared technologies have been selected since they are the most widely used technologies in current AMI deployments both in Europe [3], [54] and in the US [47]. Furthermore, reports foresee that these technologies will be predominant in this area worldwide in the coming years [55]. As it can be seen, PLC technology stands out in coverage and equipment costs compared to the other solutions [56].

The vast majority of pilot projects and deployments all over the world are based on NB-PLC using international open standards, such as PRIME, G3-PLC or Meters&More, presented in section II.

**B. GRID TELECONTROL**

The use of control signals through PLC allows the management of generation, distribution, and consumption [57],

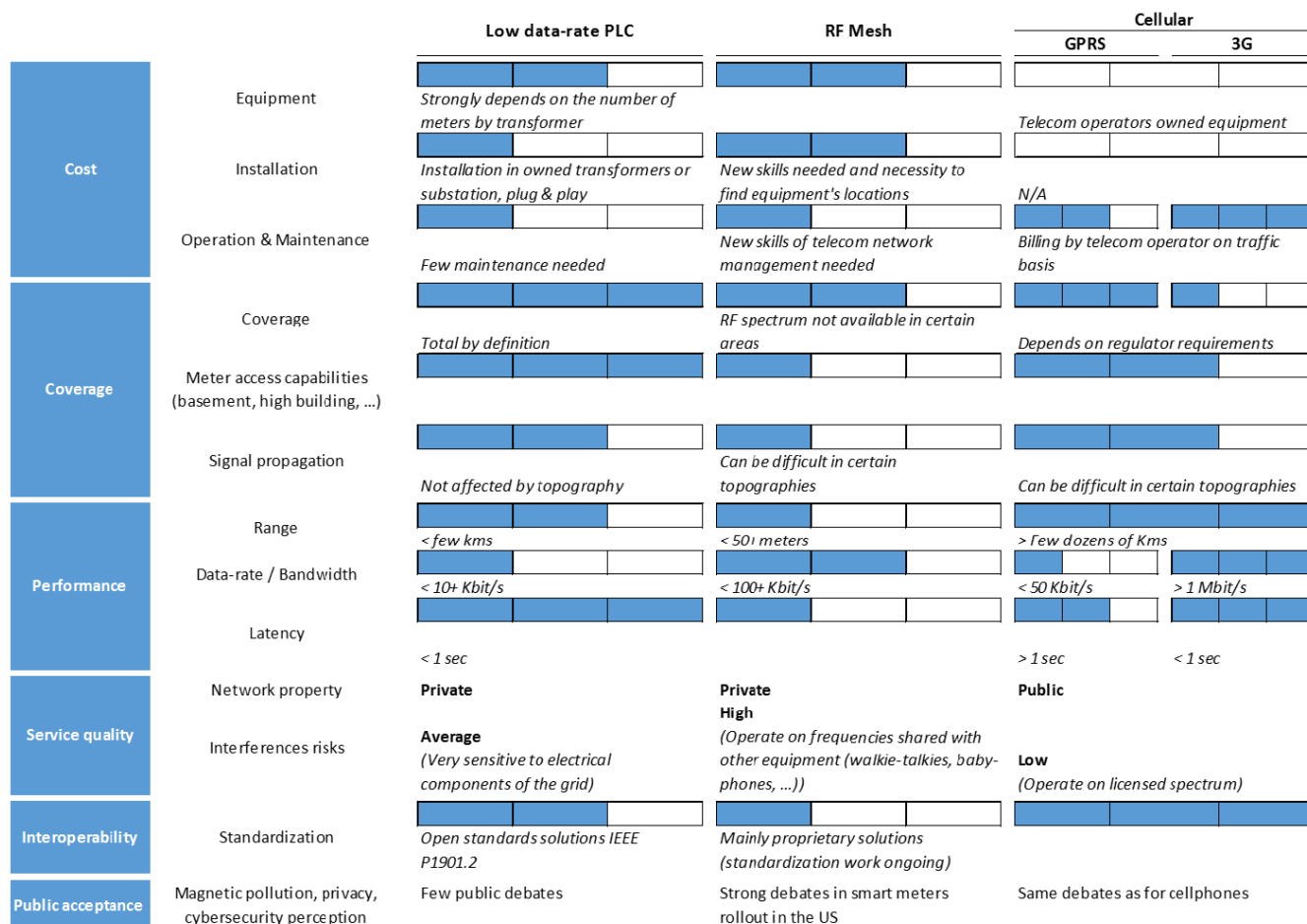

FIGURE 3. Comparison of different communications technologies in AMI systems [56].

focusing on the criterion of minimizing the electricity losses and consumption.

Deployment of BPL technologies in MV grids combined with Wide Area Networks (WAN) solutions at Secondary Substation (SS) level for SG services is a great advantage for data transmission [52]. BPL solutions offer the possibility to extend the access network to several SSs through PLC technology over the MV network. Telecontrol improves fault detection and allow self-healing of the networks through automation schemes, without the intervention of human operators (technicians).

There are industrial and mature solutions in the market that allow MV-based BPL deployments [58] to improve fault detection and reduce the response time and technician intervention time, ensuring reliability of the electricity network. Several deployments of grid control have been done using different technologies [59]; some of the standards used for AMI are also used in deployments of grid control PLC applications [60].

The benefit of PLC in this context goes beyond providing connectivity, since PLC itself can be also used for topology estimation and automatic fault detection [38]–[40], facilitating faster electric service outage identification,

reporting and restoration. Thus, it allows for immediate network response actions or even procedures to react automatically, which is key in a modern distribution grid, where impacts need to be identified and prevented before they happen.

### C. ELECTRIC VEHICLE

There are different solutions in order to manage the communication between the EV charging post and the EV. The communication standard is related to the specific plug and connector type used in the EV charging post and/or the EV [61]. There are two different types of charging AC and DC, as Table 5 and Table 6 show.

The EV DC charging uses PLC to manage the communication between the vehicle and the charging post [62]. The standard used for that purpose is Combined Charging System (CCS) specification [63], currently the only standard based on PLC technology. The main features of CCS are the safety during the charging process, the user authentication, the payment authorization, and load balancing functions. An example of the definition and architecture of the CCS standard is shown in Figure 4.

TABLE 5. AC charging technologies [61].

	Plug	Number of pins Communication	Charging Level	Voltage & Current	Maximum Power
US	Type 1 SAE J1772	3 power pins - L1,N,E	AC Level 1	1Φ 120V, up to 16A	1.9 kW
		2 control pins - CP,PP	AC Level 2	1Φ 240V, up to 80A	19.2 kW
Europe	Type 2 Mennekes	4 power pins- L1,L2,L3,N,E	AC Level 1	1Φ 230V, up to 32A	7.4 kW
		2 control pins - CP,PP	AC Level 2	1Φ 400V, up to 80A	43 kW

TABLE 6. DC charging technologies [61].

Plug	Number of pins Communication	Charging Level	Voltage & Current	Maximum Power
Type 4 SAE J1772 CCS	3 power pins - DC+,DC-,E 2 control pins - CP,PP (PLC over CP,PE)	DC Level 3	200 – 1000V DC, up to 200A	200kW
Type 4 Chademo	3 power pins - DC+,DC-,E 7 control pins (CAN communication)	DC Level 3	200 – 500V DC, up to 125A	62.5kW
Tesla US	3 power pins - DC+,DC-,E 3 power pins (reused) - L1,N,E 2 control pins - CP,PP	DC Level 3	For Model S, 400V DC, up to 300A	120kW

TABLE 7. Technical specifications of main DC charging standards [63].

Spec.	New GB/T	GB/T	CHAdEMO	CCS	Tesla
Max. Power	1,500 V x 6,000 A = 900 kW	950 V x 250 A = 237.5 kW	1,000 V x 400 A =400 kW	1,000 V x 400A =400 kW	410 V x 330 A =135 kW
Number of control pilots	2	0	3 (2+1)	1	1
Communications	CAN (SAE J1939)	CAN (SAE J1939)	CAN (ISO 11898)	PLC (ISO15118)	CAN (SAE J2411)
12 V Power supply to EV	NO	Optional (A+/-)	Yes (d1)	No	No
V2L/H/G/V	Unknown	Under development	Yes	Under Development	No
Coupler lock	Inlet	Connector	Connector	Inlet	Inlet
Availability	PRC	PRC, India	Global	EU,US, South Korea, Australia	Global (Type 2 for EU)
Related standards	IEC 618501-23-1, 23-2 (planned)	IEC 618501-23-1	IEC 618501-23-1, 23-2, IEEE2030.1	IEC 618501-23-1, SAE J1772	None
Notes	Liquid-cooled cable under development	Liquid-cooled cable not available	Liquid-cooled cable under development	Liquid-cooled cable under development	Liquid-cooled cable discontinued

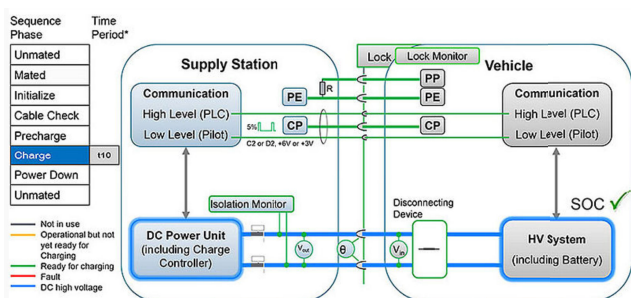

FIGURE 4. CCS standard architecture and data flow [63].

Although different technologies can be used in DC charging (see Table 7), PLC technology stands out in coverage availability and equipment cost among the rest of the solutions. Moreover, the PLC solution for charging units has the advantage of the wide PLC-based deployment of SMs for AMI.

There are different PLC deployments and projects all over the world based on CCS specification. There are more than 5,000 active charging points in Europe alone, where Germany stands out with more than 2,000 points, followed by the

United Kingdom with 1,150 charging points, and Denmark with 515 charging points.

Focusing on the projects, the most important ones using PLC technology regarding the volume of equipment in operation are listed next:

- IONITY: Formed by Volkswagen Group, BMW Group, Daimler y Ford companies. Nowadays the solution is working in Europe with European standard CCS. A map with the EV charging stations currently working and the ones which are under constructions is available in [64].
- Enel X: This project is working in the implementation of 8,500 EV charging stations in the next 5 years, most of them located in Italy [65].
- Smart Mobility: This project has 30 EV charging stations in operation by 2018, and 200 additional EV charging stations planned by 2019.
- Superchargers (Tesla): There is a plan to adapt all the superchargers network to CCS connector. EV charging stations under construction are shown in [66].

The EV deployment has been slower than expected because of “the chicken and the egg” problem: there are not many EV circulating because there are not facilities and

charging systems that enable the use of the EV, and at the same time, there is not evolution in the EV facilities because the number of EV in operation is low for further investment.

#### D. SMART CITIES

Smart Cities are closely connected to the SG services [67]. Among the many technologies that can be considered elements of a Smart City plan, energy is a prevalent one [68]. Today many cities are using SG technologies so that consumers can more intelligently make use of energy [69] (e.g., some Smart Grid-related services [70] always associated to the Smart Cities are automatic meter reading, energy efficiency, demand management, EVs for transport electrification and so on). Moreover, energy utilities own a physical network with a ubiquitous footprint that can be used for telecommunications that can avoid building a new network, or at least can leverage the utility data network already in place.

Thus Smart Cities are a promising field for PLC technologies, mainly due to the numerous services that can be considered. Beyond the already mentioned SG applications in the Smart City, cities offer a wide range of applications such as urban lighting [71], traffic control [72], and traffic lighting control [73], among others, as well as varying uses of automation such as irrigation or remote switch on/off of assets. Since all the devices or services connected to the power line can be managed through PLC, the applicability of PLC within the urban context is pretty obvious [74], and as such, is being tackled by different companies [68]. PLC technology has a good position against other technologies, because most of the nodes that want to be managed in the Smart Cities are connected to the electrical network. So, the communication network, infrastructure and system are already deployed.

##### 1) SMART LIGHTING

Lighting is one of the fastest growing application segments of Smart Cities automation. PLC communication is gaining traction, owing to its key advantages, such as the use of existing wiring infrastructure of the building. An example of BPL solution applied to Smart Cities using the lighting infrastructure can be seen in Figure 5. The solution is based on a DC, which collects the data from a set of nodes and sends them to a central system. The nodes are installed within each luminaire to manage the luminaire itself or to control and manage devices linked by radio solutions to these nodes.

##### 2) POWER QUALITY

The Power Quality (PQ) is an important issue for electric utilities and their customers. Deviations in PQ, such as momentary interruptions, voltage sags, voltage swells and harmonic distortion can impact the customer operations, causing equipment malfunctioning and significant costs in lost production and downtime. The distributed power system has been increased with solar and wind power local facilities, which make the grid more heterogeneous and difficult to

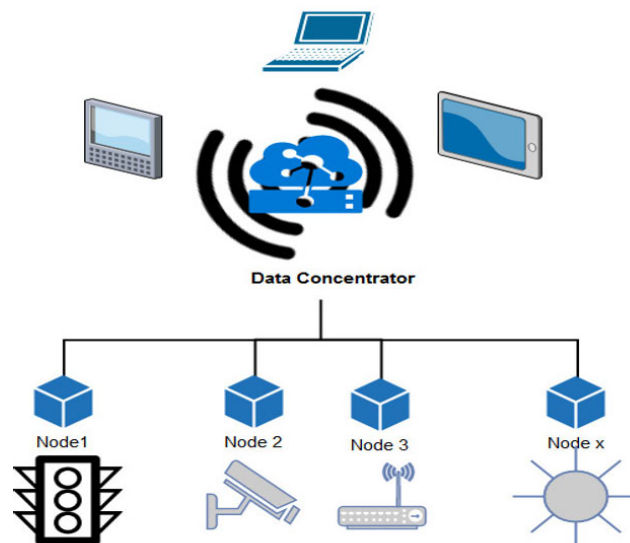

FIGURE 5. BPL application for Smart Cities.

be controlled. This interconnection between the devices connected to the grid provokes that the impact of a problem in any part of the grid can affect the rest of the connected devices.

Power monitoring systems allow a continuous monitorization of the PQ, which is measured at many different places through PLC without any additional communication lines. SMs equipped with PLC, deployed in the AMI system, can be used to collect all the PQ information of the equipment and the grid. As the SG devices are connected to electricity network, no additional infrastructure is needed. There are different deployments of PLC hardware and software techniques for PQ monitoring [75] that meets the categories of IEEE Std. 1159 [76]. The PQ monitoring and control, based on a lightweight assessment of voltage parameters to be implemented in the SMs connected to the grid, allows for the optimal real-time network operation and market services [77].

##### 3) DISTRIBUTED GENERATION

DG consists in generating electricity near the consumption points. The DG is mainly based on renewable sources, such as solar panels, small wind turbines, natural gas cells, and combined heat and power to allow the users to generate electricity to the grid. Figure 6 shows a DG system, including a variety of different generation resources.

DG may serve a home or business, or it may be part of a microgrid. If the DG is connected to the LV distribution lines, it can help to manage and deliver reliable power to additional customers and reduce electricity losses along transmission and distribution lines.

DG and microgrids are the main elements that are experiencing a huge transformation. However, PLC technologies in DG are in a preliminary status. There are several standards that allow planning and operation of energy-related production and consumption units. A Smart Distribution Grid (SDG) is considered an active service network, enabling the effective penetration of medium-sized DG, together with microgrids



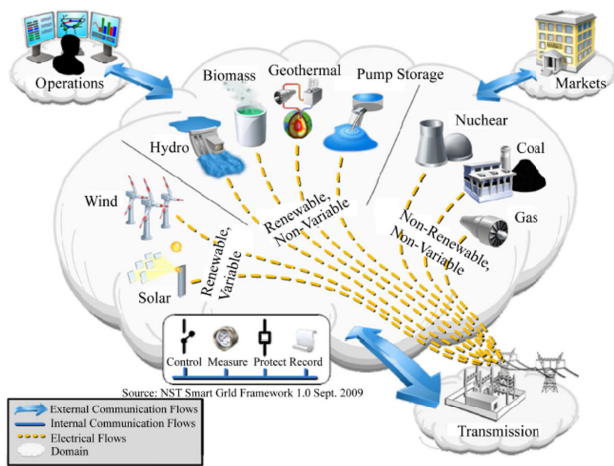

FIGURE 6. Types of DG [78].

TABLE 8. Communications technologies for Smart Distribution Grids [58].

Technology	Advantages	Disadvantages
PLC	- Extensive coverage - Cost-effective - Available infrastructure	- Signal attenuation - High noise - EMI
Wireless	- Cost-effective - Rapid installation - Mature technology	- Limited coverage - Capacity - Security
Satellite	- Global coverage - Rapid installation	- Long delay - Cost - Varying-channel
DSL	- High capacity - No shared medium	- Limited coverage - Dependency on third party
Optical fiber	- High capacity - Stable characteristics	- Cost

and active management techniques, assuring high levels of quality of service. Different communication options are used for the transition of the power grid to the SG. A detailed comparative analysis among different technologies used in SDG systems can be seen in Table 8. PLC technology stands out in coverage and availability of the infrastructure among other solutions [58].

New advanced applications, such as DG management and distribution grid monitoring, require more bandwidth and higher data rates in the order of a few kbps per second. Therefore, NB-PLC technologies are a good alternative for DG, operating in the band of 3 - 500 kHz.

Table 9 summarizes and compares the requirements of the applications of PLC in SGs presented in this section.

#### IV. CURRENT CHALLENGES IN POWER LINE COMMUNICATIONS TECHNOLOGIES

Once the main PLC technologies and their applications in SGs have been outlined, this section focuses on the main challenges that PLC technologies are currently facing and will face during the coming years. Such challenges are mainly related to meeting the requirements of novel applications based on NB-PLC network performance, and to guarantee security levels suitable for such applications.

#### A. NOISE AND NON INTENTIONAL EMISSIONS IN THE LOW VOLTAGE DISTRIBUTION

##### 1) SOURCES AND TYPES OF NOISE AND NON-INTENTIONAL EMISSIONS

Some devices connected to the electrical grid generate disturbances in the frequency range 2 - 150 kHz, commonly used by NB-PLC for Smart Metering and other SG applications [43], as it has already been introduced in the section II. Although NB-PLC technologies, such as PRIME, G3-PLC, or IEEE 1901.2, allow the use of robust modulation and coding techniques, these interfering emissions present in the transmission channel may severely degrade the communications [2], [43], [79]–[81].

These channel disturbances are mainly radioelectric noise and Non-Intentional Emissions (NIE) generated by electronic devices connected to the electrical grid. Throughout the literature, different types of noise and NIE have been identified, according to different criteria (frequency response, duration, or periodicity) [5], [82], [83]:

- Background noise: it is always present, and it usually changes slowly with time.
- Colored background noise: in contrast to white noise, the frequency response of this kind of noise is not flat. It is usually higher in lower frequencies, but it highly depends on the type of devices connected to the grid and their working regime.
- Narrowband noise: it consists of one or several amplitude-modulated narrowband emissions.
- Harmonics of the switching frequency: switching devices generate spurious narrowband signals in multiples of the switching frequency. As the switching frequency is usually above 10 kHz, some harmonics are located within the band for NB-PLC.
- Impulsive noise: impulsive signals of high amplitude during short periods of time (between microseconds and milliseconds), synchronous to the mains frequency or asynchronous (in this case, generated by the switching of power transistors for DC/AC conversion, engines and some electronic devices).

According to CENELEC [43], the European committee for electro-technical standardization, the above-mentioned types of noise and NIE in the 2-150 kHz range are generated by a wide range of devices (see Figure 7). The most relevant ones are electronic devices that include small inverters for switching (power supplies, elevators, washing machines, or engine control systems) [84]–[86], lighting equipment (compact lamps, fluorescent lamps, and LED lamps) [87]–[90], but also DERs, such as photovoltaic inverters, battery chargers, hydropower systems, or wind turbines [4], [5], [82], [86], [90]–[93]. As more renewable power generators, EV chargers and energy-efficient devices are added to the grid, the number and amplitude of the emissions is expected to be considerably higher in the next years [4], [94]. The interest in the analysis of PV panels, battery chargers, and other electronic devices that contain inverters lies in the fact that inverters usually

TABLE 9. Smart Grids application summary and requirements [25].

Service	Data rate (kbps)	Latency	Availability (%)	Security	Power supply backup
AMI	10 - 100	2 - 15 sec	99 - 99.99	High	Not necessary
DA	9.6 - 100	100 ms - 2 sec	99 - 99.999	High	6 - 48 hours
EV	9.6 - 56	2 sec - 5 min	99 - 99.99	Relatively High	Not necessary
Lighting, traffic control	~bps	100 - 300 sec	99	High	24 hours
PQ	10 - 100	2 - 15 sec	99 - 99.99	High	24 hours
DG	9.6 - 56	20 ms - 15 sec	99 - 99.99	High	1 hour

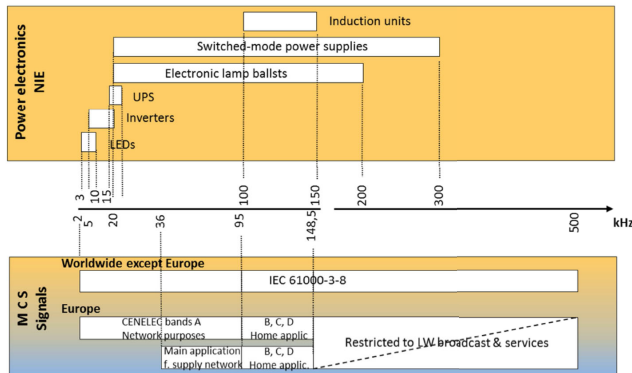

FIGURE 7. Frequency ranges for the main sources of NIE, compared to the frequency bands for NB-PLC (2 - 500 kHz) [43].

generate NIE in the harmonics of the switching frequency within the frequency range used for PLC.

CENELEC identified the frequency ranges that should be evaluated for the main sources of NIE, as Figure 7 shows.

## 2) REGULATION OF EMISSIONS

The negative effects that the noise and EMI may have on PLC, and consequently, on the development of new SG applications based on PLC, is a relevant topic for regulatory and standardization bodies. In the last years, there has been a significant effort to regulate the emissions at harmonics of the fundamental, and in general, in the frequency range immediately above the 50/60 Hz, for the sake of guaranteeing the power quality [95], [96].

A similar itinerary should be followed for the limitation of supra-harmonics in the frequency range used for NB-PLC (above 2 kHz), as there is a lack of standardization in these frequencies, in particular about the limits of emission, compatibility and immunity [85], [97], [98]. This deficiency hinders that involved devices address this problem. Currently, the discussion is focused on defining the compatibility levels; though there is an agreement for the range 2 - 30 kHz [84], an agreement for the range 30 - 150 kHz is already to be reached [43]. Additional field measurements are required to characterize the time and frequency response of the different types of noise and NIE.

In particular, CENELEC launched the SC 205 Working Group 11 to promote, gather and analyze NIE in electrical grids, and to determine adequate immunity levels

for communications. This Working Group is now demanding updated results in this area that provide the basis to re-visit criteria and reference levels [43].

Additionally, the IEC, the international body for the assessment of standards and conformity of all fields of electrotechnology, launched the joint working group of TC77A and CISPR SC/H to define requirements for the regulation of emissions, in order to ensure the compatibility of electrical products in the frequency band assigned to NB-PLC [99].

Moreover, the CISPR, in charge of developing standards to control the electromagnetic interference in electrical and electronic devices, has determined limits for NIE generated by some specific devices:

- NIE generated by lighting equipment (CISPR15, EN 55015) [100].
- NIE generated by induction cooking equipment (CISPR11, EN 55011) [101].
- Intentional emissions generated by mains communicating equipment (EN 50065-1).
- NIE generated by mains communicating equipment (EN 50065-1).

These limits, together with the voltage limits for intentional communication signals given in IEC 61000-2-5 [102] and the limits given in EN 5016 [103], related to electric power quality, were published by IEC in the document TS 62578 Ed. 2:2012 [103] (see Figure 8). However, specific limits for NIE from DERs and other types of equipment have not been established yet, so that the limits for perturbations generated by mains communicating equipment given in EN 50065-1 have been generally used as a reference [83]. These specific limits are labeled in Figure 8 as “non-intentional PLC out-of-band emission”. Additionally, the EN 50065-1 defines different levels of the limits, considering that CISPR quasi-peak and CISPR average detectors can be used [104]–[106]. Originally, these detectors were defined to be implemented by analog components; nowadays, they are usually implemented using digital signal processing [106]. Limits to NIE should in any case be defined not only considering the voltage level of interfering carriers, but including the maximum power spectral density that can be supported.

Other working groups that address the analysis of the performance and effects of supra-harmonics are the Joint Working Group CIGRE-CIRED C4.24 [96], the IEEE PES P1250 [107], and the TC7 of IEEE EMC Society [108], working in coordination with IEC SC 77A.

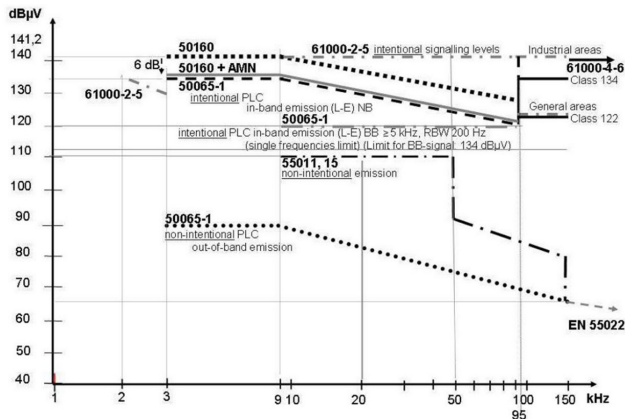

**FIGURE 8.** Recommended emission limits below 150 kHz for different scenarios [103]. The curve on the bottom represents the limits for non-intentional out-of-band emissions from PLC.

### 3) EMPIRICAL ANALYSIS OF NOISE AND EMI IN ELECTRICAL GRIDS

Due to the numerous types of noise and NIE, the wide variety of sources, and the different behavior in time and frequency, the characterization of these phenomena must have an empirical basis, which requires the development of extensive laboratory and field measurements of different sources and working conditions of the devices. This characterization must address the challenges of defining a commonly accepted measurement methodology, able to characterize the great variability in time and frequency of a wide diversity of types of noise.

The study report published by the SC 205 A of CENELEC [43] provides interesting results for a preliminary characterization of the nature and relevance of NIE generated by specific devices. In addition, some measurements campaigns have been carried out in the last years with this purpose, most of them focused on the frequency range 2 - 150 kHz, to evaluate NIE from DERs, the lighting devices of different technologies, battery chargers, and other types of appliances.

The noise and NIE generated by DERs is one of the main concerns in this area, as they may be of high amplitude and different types of noise may be present, and they are progressively more usual in the grid due to the deployment of renewable generation. Results of these measurements have identified four types of noise and NIE:

- A set of high amplitude narrowband emissions at harmonic frequencies of the switching frequency of the inverters in PV panels, battery chargers and other generation systems (see Figure 9).
- Additional narrowband emissions at specific frequencies in power generation devices (see Figure 10).
- Colored background noise (see Figure 10).
- High-level emissions in transitory periods due to coupling processes (see Figure 10).

The emissions with highest levels are those caused by inverters, as it can be shown in Figure 9 and therefore, the performance of the switching devices is the key aspect to be considered in order to reduce the levels of the

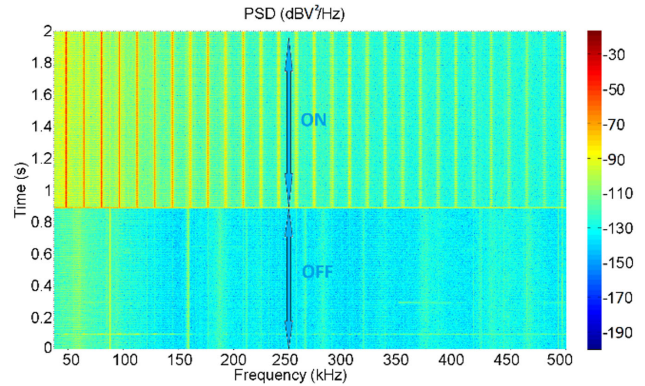

**FIGURE 9.** Measurement of the NIE generated by an inverter. They are composed of a set of supra-harmonics of the switching frequency [92].

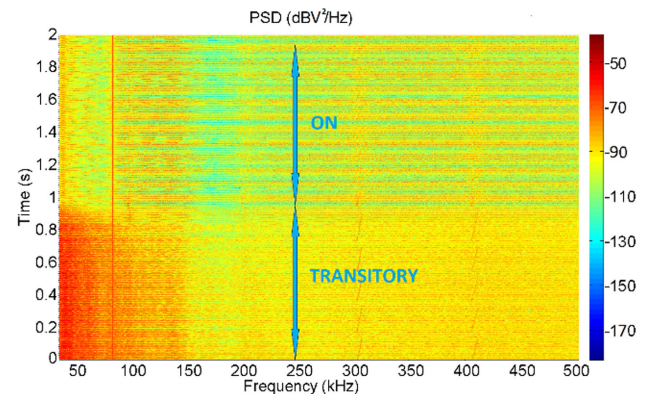

**FIGURE 10.** Measurement of the noise and NIE generated by a hydropower pump. In this case, the colored background noise is predominant; a narrowband emission at a specific frequency (87.5 kHz) is also present [92].

NIE [4], [5], [92]. As the amplitude of these harmonics decreases with frequency, the potential impact of this type of emission may be of less significance for higher frequencies; from a practical point of view, it could be possible to estimate the frequencies potentially affected by a specific switching device, as they are located at values that are multiple of the switching frequency.

Other narrowband interfering signals of high amplitude can be also generated by DERs at specific frequencies. The frequency and amplitude of these signals depend on the electronics of each specific device, and they can be characterized by measuring the NIE of each specific device in different working regimes.

The colored background noise is present in almost all the devices analyzed in the measurement campaigns, with varying characteristics both in frequency and in time. The amplitude does not clearly decrease with frequency as in the case of the harmonics of the inverters, and in some cases, higher amplitudes are shown also at higher frequencies.

The transient emissions occur during changes in the working regimes and/or coupling processes. The amplitude, duration and frequency response depend entirely on the device model. As they only occur from time to time, their effects on the communications might be limited to sporadic cases.

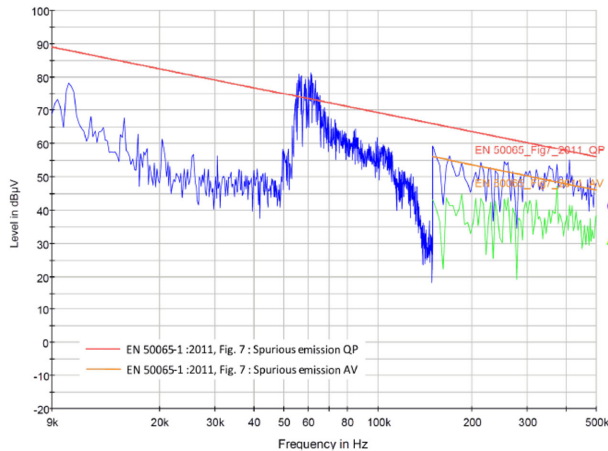

FIGURE 11. NIE generated by lighting device [43].

The NIE generated by low power LED lamps and other lighting devices are discussed in [86]–[89]. In some cases, they seem to be organized in bands [84], though it is difficult to find common patterns, due to the wide diversity of types of noise and emissions generated by different models and technologies. A representative example is shown in Figure 11.

The chargers of EVs have been identified as another significant source of noise and NIE, though there are very few measurements in the literature [5], [94]. In this case, NIE are caused by internal inverters, and the highest emission levels at switching frequency of the rectifier circuit usually occur during the time when the highest charging current is drawn by the EV [94]. In any case, the amplitudes, the frequency range, and the shape of the NIE highly depend on the charger model, the charging type, and the state of charge of the battery stage, and therefore, they vary significantly with charging conditions and with time [5]. A detailed characterization of this type of emissions is needed, and for that, additional measurements for the different types of EVs, charging devices, and batteries are required.

All these studies demonstrate the need to carry out additional field measurements, due to the wide variety of devices that generate emissions of different nature, level and variation in time and frequency. As few field measurements have been carried out for frequencies above 150 kHz, particularly for DERs and EVs, a detailed characterization for frequencies up to 500 kHz is needed, in order to estimate if these emissions might cause problems in PLC communications up to this limit.

#### 4) IMPACT ON COMMUNICATIONS

The potential impact of noise and NIE on the quality of the data transmission largely depends on the techniques used to increase the robustness of the communications against interference and impulsive noise, and therefore, to overcome the communication impairments. These techniques mainly

consist in the use of coding and modulation schemes or in the addition of time interleaving [92]:

- The OFDM technique is widely employed in NB-PLC systems, due to its good performance against frequency selective fading and narrowband interferences, as data are split into multiple carriers, and therefore, narrowband interferences only affect a small part of the bit stream. For this reason, it is a useful tool against interferences such as the high amplitude harmonics generated by switching devices.
- Coding techniques are based on inserting redundant information, which implies a lower net throughput, and therefore, a less efficient use of the spectrum. Convolutional coding is performed in PRIME, G3-PLC, and IEEE 1091.2 specifications. Additionally, G3-PLC and IEEE 1091.2 allow the additional use of Reed-Solomon coding.
- Robust modulation schemes transmit a lower number of bits per symbol, whenever the limitation in the bit rate required by the selected modulation scheme could be assumed. Three different modulation schemes were selected by PRIME, G3-PLC and IEEE 1091.2 specifications, in order to provide different rates of robustness at the expense of net throughput (DBPSK, DQPSK and D8PSK), while other schemes could be used in G3-PLC and IEEE 1091.2, depending on the required robustness (PSK, QPSK, 8PSK and 16QAM).
- The time interleaving consists on interlacing the bits in time before they are transmitted, and then, performing the reverse operation in the receiver. Thus, a short impulsive interference would affect consecutive bits in the transmission channel; but when they are reordered in the receiver, the erroneous bits are separated in time, so the errors can be more easily detected and fixed by decoding techniques. Consequently, time interleaving increases the effectiveness of coding techniques, and therefore, the robustness of the transmission against impulsive noise or rapid transitions in the propagation channel performance.
- OSI-Layer 2 network coding-based cooperative schemes to improve communication reliability in PLC channels, as an alternative to traditional retransmissions with Automatic Repeat Request (ARQ) schemes [109], [110].
- Hybrid network PLC and non-PLC deployment strategies, installing PLC-enabled gateways where noise cannot be reduced, to increase available transmitter signal level, closer to the load [48].
- Additionally, repetition techniques increase the success probability in the message reception, but also the occupancy of the channel and the percentage of the packet collisions. The basic idea is to repeat the same bit a number of times. It can be seen as a coding technique in the sense that it adds redundancy to the transmitted message. This redundancy is not so efficient as in Reed-

Solomon or convolutional encoding but the decoding process is surely computationally less intense.

- MIMO techniques-derived approaches, using the different channels that exist due to the multiwire nature of power line feeders [111].

In any case, new strategies that provide both a more robust performance against interference and the efficient use of the spectrum should be developed and tested in real environments. On the side of the devices connected to the grid, the implementation of specific filters that reduce the level of the NIE within the frequency bands used by NB-PLC would minimize the negative effect on the communications. On the side of the communication devices, the use of new coding and modulation techniques can increase the robustness, while the development of new strategies to manage data of different priority and channel occupancy would improve the spectral efficiency. In any case, the availability of a wider frequency range up to 500 kHz in Europe would allow higher data rates, robustness and development of new services. Some of these strategies are described in section V-A.2.

## B. CYBERSECURITY

The digitalization of the power grid brings many benefits, but also important risks, since it entails that such a critical infrastructure will be more exposed than ever. As a result, cybersecurity concerns have been carefully considered since the new paradigm of the SG came up. As a token of this, the first issue of the IEEE Transactions on Smart Grid published a paper on key security technologies for SGs [112], which was followed by special issues on the topic in prestigious journals and magazines [113], as well as highly cited surveys [114], [115].

Cybersecurity in PLC will be a hotter topic in the coming years, considering the high penetration of PLC technologies in SGs. In AMI deployments, for instance, the domestic infrastructure is not used to be separated from the DSO infrastructure by filters, which leaves the door open to hamper AMI communications. Reference [116] already drew the attention on the fact that SMs create a new strategic vulnerability, since if they got massively compromised, it could imply the interruption of citizen electricity supply, something that previously was only possible by attacking critical generation, transmission and distribution assets. Nevertheless, the first attacks to this kind of infrastructures have not taken this direction, but the economic one, as in Malta, where more than a thousand SMs were compromised between 2011 and 2012, incurring a power theft worth 30 M euros [117], or in Puerto Rico, where FBI found that Puerto Rico Utility Industry was losing an average of 400 M dollars from SM hacking [118].

Regarding specific vulnerabilities, [119] represents one of the first published research works on this topic. In this work, two Spanish researchers reverse engineered a SM, obtained the symmetric encryption keys, which were shared among devices. Thus, an attacker who got access to these keys would be able to send commands to the network (e.g., disable the SMs) or even had full control of it. However, the DSO

claimed that it was physically difficult to get such a sensitive information. Reference [120] represents another example related to encryption. In this case, the researchers found a breach in the authenticated encryption scheme used in OSGP. Thus, they presented several practical key-recovery attacks which entails few operations and negligible time complexity. Reference [121] deals with how to identify G3-PLC and PRIME communications in order to perform an interference attack to them.

These vulnerabilities led research community to dissect PLC technologies from the cybersecurity perspective. Thus, reference [122] presents a layer-2 security comparison between G3-PLC and IEEE 1901.2. Reference [123] presents a comprehensive analysis of cybersecurity vulnerabilities of the layers 1 and 2 of the PRIME specification, showing vulnerabilities that may involve Denial-of-Service (DoS) or privacy leaks. Reference [124] extended the analysis to a whole AMI based on PLC, including an assessment of the risk that the found vulnerabilities entail. Most of such vulnerabilities can be mitigated by encrypting lower layers of the protocol stack with existing mechanisms and by using filters in the SMs to isolate the customer facilities, although this solution would imply high costs. As a result, in practice, in many cases DLMS/COSEM has been secured as a first and easy solution. Nevertheless, reference [125] identifies and describes some vulnerabilities within DLMS/COSEM.

Much research is expected to be carried out in this area in the coming years. Since key exchange mechanisms are crucial for lower layers encryption to be effective, novel proposals are expected along this line, such as [126], where the PLC channel itself is used for both generating the common key and distributing it. The research community needs also to go beyond theoretical analysis and gather practical experience on which are the vulnerabilities that hackers actually exploit from PLC technologies and protocols, which can be achieved, e.g., by means of honeypots [127], [128]. There are also research opportunities related to the design and development of Network Intrusion Detection Systems (NIDS) [129], [130] for PLC networks. Taking into account their peculiarities, distributed approaches that coordinate the measurements from different agents deployed throughout the network may be needed. Finally, these systems need to be integrated into security dynamic risk assessment platforms [131], which allow increasing the cybersituational awareness of DSOs.

## V. RESEARCH INITIATIVES

In the following paragraphs, the authors compile a set of recent initiatives that have been proposed and tested recently, and that may provide useful advances to overcome these challenges for PLC technologies in the coming years.

### A. RECENT EXPERIMENTS

The improvement of the management and control of electricity grids is a key requirement for the transition towards the SG paradigm [2]. On one hand, the optimization of the network performance is a key aspect to make the most out

of the current communication technologies. For this reason, some analyses have been developed to get the best configuration of the communication protocols in order to improve their efficiency and capacity at each scenario [132]–[135]. On the other hand, once the communication infrastructure of NB-PLC has been deployed for AMI, it can be used for additional applications other than metering. In this line, two approaches to extend the possibilities of the PLC infrastructures are being studied: first, the IP-based data transmission in the PLC infrastructure, within the same frequency range used for Smart Metering [33], [132], [136]; and second, the use of the extended frequency range up to 500 kHz for advanced use cases [134], [137], [138]. In addition, PLC has been also recently connected with the backhauling required for the connectivity needs of 5G antennas [139].

#### 1) OPTIMIZATION OF THE COMMUNICATION PARAMETERS FOR THE IMPROVEMENT OF THE NETWORK PERFORMANCE

The appropriate configuration of the parameters of the communication protocol is a key aspect for the proper performance of all those applications based on the transmission data.

The scenario, this is, the number of devices to be connected and the distance between them (which determines, in turn, the number and length of the branches of the grid) is a determinant aspect [132], [133], [135]. Besides, some studies have demonstrated the great influence of the grid topology in the communications performance, as it conditions the traffic profile and the latency of the communications [132]–[135]. Consequently, the capacity and latency values for two networks containing the same number of SMs, but with a different layout, may differ considerably.

On this matter, two interesting studies [134], [135] demonstrate the significance of adapting the communication parameters, mainly those that provide an adequate MAC layer parametrization, to the specific constraints of each scenario, in order to improve the network performance. In particular, the potential of the MAC layer to improve the efficiency of the transmission is evaluated in [134], as some strategies not defined in the standard provide better performance in some particular scenarios. Moreover, in [135], the possibilities of the configuration of the PRIME technology are analyzed, as the configuration of the communication parameters is left to manufacturer discretion, showing that the specific configurations must be adapted to the particularities and requirements of each situation.

Some rigorous experiments in scenarios isolated from external disturbances have been developed in the last years. Although they entail remarkable costs (at least laboratory facilities and expensive equipment are required), they provide objective and representative results. The European SENSIBLE project [140], where the aim is to understand the economic benefits that energy storage can bring to households, communities, and commercial buildings, is an example of multi-tenant demonstrators built in the cities of Evora

(Portugal), Nottingham (UK) and Nuremburg (Germany). Alternatively, some private companies have also followed this approach in order to understand and experiment with power grids and telecommunication networks. Such is the case of the mock-up facilities available in the Iberdrola Campus [141].

#### 2) MITIGATION TECHNIQUES AGAINST NOISE AND INTERFERING EMISSIONS

As it has been described in the previous section, the disturbance generated by conducted noise and NIE in the electrical grids is one of the most relevant challenges to be solved for the proper performance of NB-PLC, as they can limit the availability and efficiency of the communications. Several mitigation techniques have been proposed to avoid this problem.

The previous step to the application of mitigation techniques is the proper identification of the interfering emission. This is not a simple matter, as the noise is coupled among the cables of the different phases and propagated through the network. A solution to detect the source in a short time, without the interruption of the power mains and without the need of disconnecting loads to identify the interfering source, is proposed in [142]. The basis of this proposal is the comparison of the noise level at the different phases of the SMs. Hence, the noise level is usually higher in the phase of the load that injects the noise; on the contrary, within the SMs, the noise is coupled to the rest of the cables due to the low attenuation of the meter in the PLC frequency bands. As a result, in the SM connected close to the noisy load, the input noise level will be higher in one phase, but the output level will be similar in the three phases. This solution could be integrated within the SMs connected to the distribution grid. One of mitigation technique usually found in the field is the use of filters near the noise sources, in order to limit the propagation of noise and NIE through the grid; this is, near the industrial inverters and power sources, or even at the customer premises, to filter out emissions generated by domestic appliances and DERs. The filters required for this use must address several requirements, such as tolerating currents up to tens of amperes, high input impedance and stability for the whole range of operating conditions. In [5], a configurable passive filter, specifically designed to remove noise and NIE in the last mile of AMI, is proposed and tested in different noise scenarios; this interesting study demonstrates the need of considering the internal operation of the SMs.

Another technique to be used is the design of novel modulation schemes, such as Orthogonal Poly-Phase-based Multicarrier Code Division Multiple Access (OPP-MC-CDMA), proposed to overcome the effects of burst-shaped noise and multipath frequency-selective fading in BPL networks [143]. Some memoryless nonlinearity techniques have been also tested to mitigate the effects of impulsive noise [144], [145].

Some other techniques to mitigate the effects of impulsive noise are based on the analysis of the transmission medium, such as compressive sensing [146]–[148], or in the use of DCs with three phase injection capabilities [149].

### 3) IP-BASED DATA TRANSMISSION OVER NB-PLC

AMI infrastructure might allow additional applications beyond Smart Metering. In [136], laboratory tests demonstrated that IP can be implemented in the available channel of a NB-PLC system (specifically, PRIME 1.3.6 technology in CENELEC A frequency band). IP is a mature open technology that provides the basis for higher layer protocols that lead to reliable, simple, secure and robust applications [150]. These features can face several challenges of the SG such as scalability, resilience and reliability. In fact, IP is increasingly being used in monitoring and control applications in the energy sector, such as demand management, or control of DG and distributed storage [151]. In any case, the possible applications of the implementation of IP must be compatible with the metering traffic flows of the AMI system.

Field trials performed in a real environment (a real microgrid implementing a PLC-based AMI system consisting of 21 nodes) demonstrated the availability of some limited channel capacity for additional IP-based applications beyond AMI [132], [133]. Hence, applications that require data rates in the order of bps up to a few kbps could be addressed, though the resultant data rate highly depends on the topology of the subnetwork involved in the transmission [133]. On the contrary, applications requiring real-time or near real-time responses would not be possible. Therefore, it is not a solution for applications requiring low latency [33].

In summary, extra channel capacity can be used for additional applications without strict latency requirements, whose data rates vary between bps and a few kbps, such as monitoring of the DERs of a microgrid, some types of communications in home networks, signaling and monitoring in wide area networks or signaling tasks for utilities and grid operators [133].

### 4) PERFORMANCE OF PLC IN FREQUENCIES UP TO 500 KHZ

The NB-PLC has been the first option for many DSOs in Europe for the implementation of AMI [16]. In Europe, CENELEC A band (3 - 95 kHz) is reserved for communications of electricity suppliers and distributors in deployments of PLC systems compliant with EN 50065-1 [152], as harmonized standard. The EN 50065-1 also establishes certain limits for transmissions in the so-called B, C and D bands, from 95 kHz to 148.5 kHz, for use in other environments, such as in-home services [8]. However, in view of the increasing communication problems due to NIE in the CENELEC A band and the need for higher bandwidths to allocate new services, several European markets are considering the frequency band up to 500 kHz [43], [137], [138]. This frequency range has been historically used for PLC in USA (FCC) and Asia (ARIB), as it has already been mentioned.

Some field trials of NB-PLC in frequency bands higher than CENELEC A were developed in [137], and the distance between the SS and reception points and different kind of interference were found as relevant aspects to be faced in

order to achieve the proper performance of the communications in these higher frequencies.

Moreover, as it was also mentioned in section I, the LV electrical grid is a harsh transmission medium, as it is frequency and time varying and highly dependent on the number and location of the loads connected at a certain moment, which results in one of the main drawbacks for its use for NB-PLC systems. A detailed characterization of the transmission medium in this new frequency range (150 - 500 kHz) is the best way to evaluate the performance of the communication standards in terms of capacity, coverage, data rate, and robustness. Moreover, the characterization of NIE in the electrical grid has been traditionally limited to the frequency range up to 150 kHz. However, there is an increasing interest in Europe to extend this characterization up to 500 kHz [43]. As few field measurements have been carried out for these higher frequencies, particularly for DERs, a detailed characterization of the different types of NIE in the frequency range up to 500 kHz is needed in order to estimate if these emissions might cause problems in the communications, and therefore, if they should be limited through regulation [92].

Frequency range up to 500 kHz is also evaluated in [153] in order to provide new possibilities of configuration for AMI in grid topologies composed of a lower number of SMs per substation. Based on the hypothesis that communications through transformer substations might be possible in higher frequencies, due to a lower attenuation in this frequency range, it suggests the connection between devices located in a MV-LV environment by means of a switch node for frequency channel conversion, instead of data concentrator working at lower frequencies.

### 5) IN-BAND FULL-DUPLEX PLC

The In-Band Full-Duplexing (IBFD) is evaluated in [154], [155] as a solution to increase the spectral efficiency. It consists of enabling simultaneous bidirectional data communication in the same frequency band. The simulation results of this study show a clear improvement of the data rate, since an increase over 80 % in median bidirectional data rates is achieved under typical in-home power line networking conditions, without any additional power or bandwidth requirement.

Additionally, the IBDF technique is proposed also for the transmitter devices to sense the operating spectrum, in order to reduce the impact of the electromagnetic interference caused by unintentional PLC radiation on broadcast radio services, digital subscriber line communications, and neighboring PLC systems in a heterogeneous PLC environment [156]. Hence, some EMC compatibility issues could be addressed at PLC deployments.

The implementation of this proposal requires incorporating digital echo cancellation filtering to suppress the self-interference, considering the linear periodically time-varying channel conditions of the PLC scenarios [157].

## B. SIMULATION AND CO-SIMULATION

As we have already mentioned, the central concept of SG is the convergence of ICT and the Power System Engineering. As a matter of fact, recent developments in ICT together with vast deployments of demand-side energy management have allowed the SG concept to go one step further. Thus, in order to assess the performance of the new SG applications, effects of both dimensions, the ICT and the Power dimension, need to be carefully evaluated.

Simulation has always been a fundamental tool to design and evaluate the performance of power [158]–[161] or/and telecommunication systems [160]–[162]. The main motivation for simulation is to reduce the cost of evaluating the effect of new features or upgrades in very large networks without the potential loss of service. A simulation approach reduces this kind of risks and allows for the design and evaluation of different solutions before a real-life deployment. In addition to this, simulation allows for emulating the evolution of the system at a faster-than-real-time speed, which facilitates the development of new technologies. In summary, the main benefits of this option are flexibility, scalability, and cost-effectiveness. However, the significance and relevance of the obtained results are tightly related to how well the model behind the simulations fit the real conditions of the scenarios under test [129]. Simulation tools are especially important for research purposes in SG scenarios since the access to such a critical infrastructure for carrying out experiments and tests is extremely limited.

The underlying challenge that exists when simulating SGs scenarios is the need to combine the simulation for both the Power and the ICT dimension together with the applications running on top of them. However, typically, state-of-the-art power grid simulators do not consider communication protocols and their corresponding effects or common traffic patterns in SGs infrastructures. The same holds for the most used telecommunication simulators, which do not include the impact on the traffic due to the operation mode of the SG. In the following subsections, we elaborate on some strategies that are intended to fill this gap and provide a list of the most recent efforts in order to couple together both the Power Grid and the ICT effects (power and communications, in short, in the following sections).

### 1) USE OF DECOUPLED SIMULATIONS

A first alternative to real premises would be to model each dimension of the problem separately (i.e., power and communications related) in a professional or community-validated simulator.

The advantage of this method is clear: using state-of-the-art models for each part of the whole problem. However, this approach is limited due to its decoupled design: simulation outputs are isolated results from both models. It could be argued the model may not be completely realistic since the Power Grid model does not consider any details about the

communications model and vice versa. After all, these interactions are what the SGs is all about.

Nevertheless, this approach can be useful to assess a communication technology (or a Power Grid-related scenario). Thus, in [163] a PLC channel simulator based on ns-3 is presented.

In [164] a distributed simulation environment based on Linux processes is proposed for PRIME. One of the strongest points of this work is that real commercial PRIME Alliance certified code is used in such processes to model the network nodes.

The PRIME network simulator SimPRIME [165] also allows carrying out PRIME network simulations by combining MATLAB and OMNeT++. SimPRIME has been widely used for research works encompassing the evaluation of PRIME performance for DR in presence of different types of noises [81], the evaluation of PRIME performance for AMI in different scenarios [166]–[168] and varying different MAC parameters [169], the evaluation of the use of the contention free period defined in the PRIME standard [170], the evaluation of optimal switch positioning [171], or the evaluation of different policies to promote PRIME service nodes to switches at the base node [172].

References [173], [174] present two PRIME network simulators also based on OMNeT++ which were developed almost at the same time as SimPRIME. The work presented in [173] focuses very much on the PHY layer, notably on the probability of error. The work presented in [174], instead, focuses on a very relevant practical scenario, the remote and massive upgrade of firmware in PRIME networks, from the DSO perspective.

Reference [175] also proposes a network simulator for G3-PLC which combines MATLAB, to model the PHY layer phenomena, with OMNeT++, to model the upper layer effects.

Regarding BPL, [51] also uses simulations to evaluate the suitability of BPL as a backhaul solution in AMI. On the other side, [176] presents a simulation tool based on MATLAB which focuses on MV-BPL cells. This tool allows varying most of the technical parameters of such cells and observing the impact on their performance in terms of the Round Trip Time (RTT).

### 2) MONOLITHIC SIMULATIONS

In order to avoid the main previous drawback of lack of interactions between the models, one straight-forward solution is to design a single model that takes into account the specifics of both the power and the communication dimensions. However, writing a new simulation engine from scratch is a time-consuming, expensive and complex task. Indeed, it is especially complex due to the kind of effects that needs to be modelled due to each dimension of the overall problem. In the case of the communications, simulations are based on event-based models. This is, nothing virtually happens between two consecutive and discrete time instant; for instance, the start of transmission and the end of transmission



of a packet. In the case of the Power Grid models, simulators are typically focused on solving load-flow dynamics and transients via differential equations. Nevertheless, there are some example of such monolith simulators in the literature; such is the case of the EPOCHS [177] or the GECHO [178] simulators.

In other cases, a state-of-the-art simulation tool validated in one of the domains adds libraries or modules in order to consider the effects of the other dimension. However, due to the previously described differences in the fundamentals of the problem under consideration, this approach leads to simplifications. One example of this would be the GridLAB-D platform [179]. GridLAB-D is an open-source power system modeling and simulation environment that counts with a communications library. This library models the communication channel in terms of bandwidth, statistics of latency and congestion. However, no effects such as attenuation, Signal-to-Noise Ratio (SNR), channel collisions, or Bit-Error-Rate (BER) are considered.

### 3) COLLECTION OF SPECIFIC SIMULATORS: CO-SIMULATION

An alternative to all previous approaches that tries to overcome the main disadvantages is the option of coupling a heterogeneous set of submodules or simulators and make them work together synchronously. This concept is commonly referred to as Co-simulation. This approach is computationally more complex than previous ones but offers the advantage of producing more realistic results. This can be achieved since the environment consists of a number of state-of-the-art tools, each one of them working on the dimension for which they were originally designed to. The co-simulation environment enables the interaction of each model so that phenomena taking place on one dimension have consequences on the other one. Thus, co-simulation presents a great potential for assessing power distribution networks controlled by means of PLC technologies, since some situations that may require actions from the power perspective (e.g., an PV inverter starts working) may affect the performance of the communications (e.g., a noise associated to the inverter appears in the PLC band). As mentioned, a co-simulation environment is composed of a set of coupled simulators that cooperate with each other. Simulators are coupled by dynamically connecting the models using their input and output variables, so that the output of one simulator becomes the input of the other and vice versa. The variable exchange, time synchronization, and execution coordination are, in the most general case, facilitated in runtime by a so-called Master Algorithm, which orchestrates the entire co-simulation. A scheme of this concept is shown in Figure 12.

A simulator is defined as a software package that contains the model of a system and a solver (see Figure 13), which carries out calculations based on the model and on input variables. In addition, the model and the solver, i.e., the simulator, predict the behavior of a real system under a set of specified conditions.

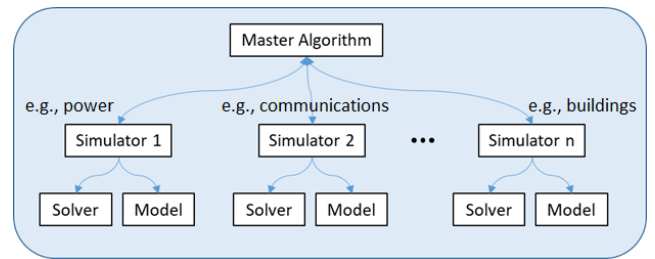

FIGURE 12. Co-simulation general scheme.

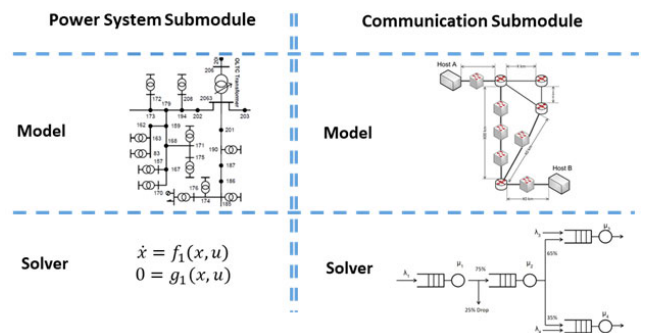

FIGURE 13. Simulators with Submodules consisting of a Model and a Solver.

With this configuration, the power system simulator makes no simplifications about the communication networks and uses a solver targeted for the specific problem of computing the current-flows or the power circuit characteristics. The same occurs with the communication simulator or any additional model to be considered in the co-simulation environment.

The interface between the simulators involved in a co-simulation environment is an issue still to be solved. As defined in [180], [181] submodules within a co-simulation need to exchange data with each other during various stages of the simulation workflow (e.g., model instantiation, initialization, runtime, and data export). The interface between the models can be implemented via shared memory, if all the simulators can access one common memory; via network communication protocols; or application program interfaces (APIs). However, two interface types that are evolving as standards for coupling physical models and simulators are the Hardware Level Architecture (HLA) [182] and the Functional Mockup Interface (FMI) [183].

As it has already been said, co-simulation platforms represent a very promising solution to increase the realism and significance of PLC simulations taking into account their close relation with the Power Grid. Thus, this approach would allow, e.g., that when a PV panel connects to the network in the power part, an interference appears in the PLC communications. However, there are no co-simulation tools for PLC available in the state-of-the-art, which leaves the door open for future research work.

## VI. CONCLUSIONS

PLC technologies are used in a wide range of industrial applications, ranging from home automation and industrial

manufacturing to AMI and telecontrol within the so-called SG. SGs are the area where PLC has clear greater expansion possibilities in the next years. However, electric cables represent a harsh communications medium, and much research has been carried out in the last decades to improve their performance and make them suitable for new scenarios. This paper provides a review of the role, status, and challenges to PLC, based on the authors combined theoretical and practical experience. Thus, after providing an overview of the different PLC technologies and configurations available in the market and of their applications in different sectors, the paper focuses on the challenges that the PLC technologies will face in the coming years, paying special attention to SGs in general, and AMI scenarios with presence of DG and EV in particular. One of such challenges is the combination of availability and performance to ensure communication when monitoring and controlling equipment (grid edge technologies), such as DG and EV, which causes noises and NIE in the frequency where PLC works. In order to tackle this challenge, experimentation of current and new configurations of PLC in these novel scenarios will be a key aspect. Such experimentation will have to combine lab tests and field trials with simulations, in order to achieve a good trade-off between reliability and trustworthiness of the results and cost-effectiveness, flexibility and scalability. Co-simulation schemes are particularly promising to analyze the performance in challenging or future scenarios. Cybersecurity is one of the most relevant challenges for PLC and SG. The theoretical analysis of technologies and protocols vulnerabilities will give way to real experiments of how such vulnerabilities can be actually exploited in controlled environments, such as honeypots. Furthermore, additional security mechanisms (e.g., encrypting lower layers of the protocol stack) and pieces of hardware and software (e.g., NIDS) will be designed and developed in the coming years and they need to be integrated into dynamic security risk assessment tools which allow increasing utilities cybersituational awareness of the unprecedented IoT infrastructure they will be in charge. While PLC technologies have always been challenged by other non-PLC alternatives (in particular, wireless technologies), the already existing massive deployments already carried out with PLC and the perfect fit of PLC with the SG ecosystem, guarantee a high market for PLC during the coming years. Research, development and industrial solutions need to be fostered to make PLC stand up to the challenge and continue being the preferred option for SGs. Thus, there is a long life ahead of the PLC community to continue contributing to the next PLC technology solutions.

## REFERENCES

- [1] G. López, J. I. Moreno, H. Amarís, and F. Salazar, "Paving the road toward smart grids through large-scale advanced metering infrastructures," *Electr. Power Syst. Res.*, vol. 120, pp. 194–205, Mar. 2015.
- [2] N. Uribe-Pé, L. Hernández, D. de la Vega, and I. Angulo, "State of the art and trends review of smart metering in electricity grids," *Appl. Sci.*, vol. 6, no. 3, p. 68, 2016.
- [3] N. Andreadou, M. O. Guardiola, and G. Fulli, "Telecommunication technologies for smart grid projects with focus on smart metering applications," *Energies J.*, vol. 9, no. 5, p. 375, 2016.
- [4] N. Uribe-Pérez, I. Angulo, L. Hernández-Callejo, T. Arzuaga, D. de la Vega, and A. Arrinda, "Study of unwanted emissions in the CENELEC-A band generated by distributed energy resources and their influence over narrow band power line communications," *Energies*, vol. 9, no. 12, p. 1007, 2016.
- [5] G. López, J. I. Moreno, E. Sánchez, C. Martínez, and F. Martín, "Noise sources, effects and countermeasures in narrowband power-line communications networks: A practical approach," *Energies*, vol. 10, no. 8, p. 1238, 2017.
- [6] B. Astarios, A. Kaakeh, M. Lombardi, and J. Scalise, "The future of electricity: New technologies transforming the grid edge," *World Econ. Forum*, 2017. [Online]. Available: [http://www3.weforum.org/docs/WEF\\_Future\\_of\\_Electricity\\_2017.pdf](http://www3.weforum.org/docs/WEF_Future_of_Electricity_2017.pdf)
- [7] D. Malone, L. Lampe, A. M. Tonello, and A. G. Dabak, "Guest editorial power line communications and its integration with the networking ecosystem," *IEEE J. Sel. Areas Commun.*, vol. 34, no. 7, pp. 1933–1934, Jul. 2016.
- [8] C. Cano, A. Pittolo, D. Malone, L. Lampe, A. M. Tonello, and A. G. Dabak, "State of the art in power line communications: From the applications to the medium," *IEEE J. Sel. Areas Commun.*, vol. 34, no. 7, pp. 1935–1952, Jul. 2016.
- [9] K. Sharma and L. M. Saini, "Power-line communications for smart grid: Progress, challenges, opportunities and status," *Renew. Sustain. Energy Rev.*, vol. 67, pp. 704–751, Jan. 2017.
- [10] S. Galli, A. Scaglione, and Z. Wang, "For the grid and through the grid: The role of power line communications in the smart grid," *Proc. IEEE*, vol. 99, no. 6, pp. 998–1027, Jun. 2011.
- [11] L. Lampe, A. Tonello, and T. Swart, *Power Line Communications: Principles, Standards and Applications from Multimedia to Smart Grid*. Hoboken, NJ, USA: Wiley, 2016. [Online]. Available: <https://books.google.es/books?id=YIrlCwAAQBAJ>
- [12] S. T. Mak and T. G. Moore, "TWACS, a new viable two-way automatic communication system for distribution networks. Part II: Inbound communication," *IEEE Trans. Power App. Syst.*, vol. PAS-103, no. 8, pp. 2141–2147, Aug. 1984.
- [13] S. T. Mak and D. L. Reed, "TWACS, a new viable two-way automatic communication system for distribution networks. Part I: Outbound communication," *IEEE Trans. Power App. Syst.*, vol. PAS-101, no. 8, pp. 2941–2949, Aug. 1982.
- [14] A. A. Atayero, A. S. Alatishe, and Y. A. Ivanov, "Power line communication technologies: Modeling and simulation of prime physical layer," in *Proc. World Congr. Eng. Comput. Sci.*, vol. 2, 2012, pp. 931–936.
- [15] *OSGP Alliance*. Accessed: Mar. 29, 2019. [Online]. Available: <http://osgp.org/en/about>
- [16] A. Haidine, A. Tabone, and J. Müller, "Deployment of power line communication by European utilities in advanced metering infrastructure," in *Proc. IEEE 17th Int. Symp. Power Line Commun. Appl.*, Mar. 2013, pp. 126–130.
- [17] *Meters and More Alliance*. Accessed: Mar. 29, 2019. [Online]. Available: <http://www.metersandmore.com/>
- [18] *PRIME Alliance*. Accessed: Mar. 29, 2019. [Online]. Available: <http://www.prime-alliance.org/>
- [19] *Narrowband Orthogonal Frequency Division Multiplexing Power Line Communication Transceivers for PRIME Networks*, Standard ITU-T G.9904, 2012.
- [20] *G3-PLC Alliance*. Accessed: Mar. 29, 2019. [Online]. Available: <http://www.g3-plc.com/home/>
- [21] *Narrowband Orthogonal Frequency Division Multiplexing Power Line Communication Transceivers for G3-PLC Networks*, Standard ITU-T G.9903, 2012.
- [22] J. Matanza, S. Alexandres, and C. Rodríguez-Morcillo, "Performance evaluation of two narrowband PLC systems: PRIME and G3," *Comput. Standards Interfaces*, vol. 36, no. 1, pp. 198–208, 2013.
- [23] "Excerpt from compation specification for energy metering architecture and protocols," DLMS User Assoc., Tech. Rep., 2009. [Online]. Available: <https://www.dlms.com/the-association/who-we-are>
- [24] "Excerpt from COSEM—Identification system and interface classes," DLMS User Assoc., Tech. Rep., 2010.
- [25] A. Sendin, M. A. Sanchez-Fornie, I. Berganza, J. Simon, and I. Urrutia, *Telecommunication Networks for the Smart Grid*. Norwood, MA, USA: Artech House, 2016.
- [26] S. Galli and O. Logvinov, "Recent developments in the standardization of power line communications within the IEEE," *IEEE Commun. Mag.*, vol. 46, no. 7, pp. 64–71, Jul. 2008.
- [27] V. Oksman and S. Galli, "G.hn: The new ITU-T home networking standard," *IEEE Commun. Mag.*, vol. 47, no. 10, pp. 138–145, Oct. 2009.

- [28] *IEEE Standard for Medium Frequency (Less Than 12 MHz) Power Line Communications for Smart Grid Applications*, IEEE Standard 1901.1-2018, May 2018.
- [29] *IEEE Standard for Broadband over Power Line Networks: Medium Access Control and Physical Layer Specifications—Amendment 1: Enhancement for Internet of Things Applications*, IEEE Standard 1901a-2019, Jun. 2019.
- [30] *Panasonic's Next-Generation HD-PLC, BPL Communication Technology Adopted as IEEE 1901a Standard*. Accessed: Mar. 29, 2019. [Online]. Available: <https://news.panasonic.com/global/press/data/2019/03/en190325-4/en190325-4.html>
- [31] Market&Market. *Power Line Carrier Communication Market*. Accessed: Dec. 2017. [Online]. Available: <https://www.marketsandmarkets.com/Market-Reports/power-line-communication-plc-market-912.html>
- [32] *IEEE Forum Smart Grids for Smart Cities*. Accessed: Mar. 29, 2019. [Online]. Available: <http://ieeesg4sc.org/>
- [33] N. Uribe-Pérez, I. Angulo, D. de la Vega, T. Arzuaga, I. Fernández, and A. Arrinda, "Smart grid applications for a practical implementation of IP over narrowband power line communications," *Energies*, vol. 10, no. 11, p. 1782, 2017.
- [34] L. Marrón, X. Osorio, A. Llano, A. Arzuaga, and A. Sendin, "Low voltage feeder identification for smart grids with standard narrowband PLC smart meters," in *Proc. IEEE 17th Int. Symp. Power Line Commun. Appl.*, Mar. 2013, pp. 120–125.
- [35] A. Sendin, I. Berganza, A. Arzuaga, X. Osorio, I. Urrutia, and P. Angueira, "Enhanced operation of electricity distribution grids through smart metering PLC network monitoring, analysis and grid conditioning," *Energies*, vol. 6, no. 1, pp. 539–556, 2013.
- [36] G. Prasad, Y. Huo, L. Lampe, A. Mengi, and V. C. M. Leung, "Fault diagnostics with legacy power line modems," in *Proc. IEEE Int. Symp. Power Line Commun. Appl. (ISPLC)*, Apr. 2019, pp. 1–6.
- [37] Y. Huo, G. Prasad, L. Lampe, and C. M. V. Leung, "Smart-grid monitoring: Enhanced machine learning for cable diagnostics," in *Proc. IEEE Int. Symp. Power Line Commun. Appl. (ISPLC)*, Apr. 2019, pp. 1–6.
- [38] Y. Huo, G. Prasad, L. Atanackovic, L. Lampe, and V. C. M. Leung, "Grid surveillance and diagnostics using power line communications," in *Proc. IEEE Int. Symp. Power Line Commun. Appl. (ISPLC)*, Apr. 2018, pp. 1–6.
- [39] M. O. Ahmed and L. Lampe, "Power line communications for low-voltage power grid tomography," *IEEE Trans. Commun.*, vol. 61, no. 12, pp. 5163–5175, Dec. 2013.
- [40] F. Passerini and A. M. Tonello, "Smart grid monitoring using power line modems: Anomaly detection and localization," *IEEE Trans. Smart Grid*, to be published.
- [41] *Communication Network Solutions for Transmission and Distribution Grids*. Accessed: Mar. 29, 2019. [Online]. Available: <http://siemens.com/smart-communication>
- [42] A. Sendin, I. Peña, and P. Angueira, "Strategies for power line communications smart metering network deployment," *Energies*, vol. 7, no. 4, pp. 2377–2420, 2014.
- [43] *Electromagnetic Interference Between Electrical Equipment/Systems in the Frequency Range Below 150 khz*, Standard CENELEC SC 205A, 2015.
- [44] *Cle/tr 50669. Investigation Results on Electromagnetic Interference in the Frequency Range Below 150 khz*, Standard CENELEC SC 205A, 2017.
- [45] *Advanced Metering Infrastructure*. Accessed: Mar. 29, 2019. [Online]. Available: <https://www.ferc.gov/CalendarFiles/20070423091846-EPRI%20-%20Advanced%20Metering.pdf>
- [46] S. Vukmirović, A. Erdeljan, F. Kulić, and S. Luković, "Software architecture for smart metering systems with virtual power plant," in *Proc. 15th IEEE Medit. Electrotech. Conf. (MELECON)*, Apr. 2010, pp. 448–451.
- [47] "Advanced metering infrastructure and customer system. Results from the smart grid investment grant program," U.S. Dept. Energy, Washington, DC, USA, Tech. Rep., 2016. [Online]. Available: [https://www.energy.gov/sites/prod/files/2016/12/f34/AMI%20Summary%20Report\\_09-26-16.pdf](https://www.energy.gov/sites/prod/files/2016/12/f34/AMI%20Summary%20Report_09-26-16.pdf)
- [48] A. Sendin, J. S. Gomez, I. Urrutia, M. Solaz, M. Sharma, T. Arzuaga, F. Guerrero, and L. Molero, "Large-scale PLC gateway-based architecture for smart metering deployments," in *Proc. IEEE Int. Symp. Power Line Commun. Appl. (ISPLC)*, Apr. 2018, pp. 1–6.
- [49] T. A. Short, *Electric Power Distribution Equipment and Systems*. Boca Raton, FL, USA: CRC Press, 2018.
- [50] G. Xu, S. Yim, I. H. Kim, T. Pande, and X. Lu, "Implementation and field test results of a software defined PLC modem," in *Proc. IEEE Int. Symp. Power Line Commun. Appl.*, Mar. 2012, pp. 66–71.
- [51] A. Ikpehai, B. Adebisi, and K. M. Rabie, "Broadband PLC for clustered advanced metering infrastructure (AMI) architecture," *Energies*, vol. 9, no. 7, p. 569, 2016.
- [52] A. Sendin, J. Simon, I. Urrutia, and I. Berganza, "PLC deployment and architecture for smart grid applications in iberdrola," in *Proc. 18th IEEE Int. Symp. Power Line Commun. Appl.*, Mar./Apr. 2014, pp. 173–178.
- [53] A. Sendin, J. Simon, M. Solaz, L. Andersson, and M. Maurer, "MVBPL—Reliable, future proof and cost efficient," in *Proc. 23rd Int. Conf. Electr. Distrib. (CIRED)*, Lyon, France, 2015, pp. 15–18.
- [54] *European Commission Joint Research Center—Smart Metering Deployment in the European Union*. Accessed: Jun. 2, 2019. [Online]. Available: <https://ses.jrc.ec.europa.eu/smart-metering-deployment-european-union>
- [55] *Market Insight—Digitalization: 2019 Smart Metering Milestones*. Accessed: Jun. 2, 2019. [Online]. Available: <https://technology.ihsc.com/608364/digitalization-2019-smart-metering-milestones>
- [56] *Which Communications Technologies for AMI Projects?* Accessed: Mar. 29, 2019. [Online]. Available: <https://www.ferc.gov/CalendarFiles/20070423091846-EPRI>
- [57] L. Lampe, A. M. Tonello, and D. Shaver, "Power line communications for automation networks and smart grid [guest editorial]," *IEEE Commun. Mag.*, vol. 49, no. 12, pp. 26–27, Dec. 2011.
- [58] T. A. Papadopoulos, C. G. Kaloudas, A. I. Chrysochos, and G. K. Papagiannis, "Application of narrowband power-line communication in medium-voltage smart distribution grids," *IEEE Trans. Power Del.*, vol. 28, no. 2, pp. 981–988, Apr. 2013.
- [59] J. A. Valparis, A. Amezua, J. A. Sanchez, A. Sendin, J. Simon, and S. Dominiak, "Complete MV-BPL communications solution for large ami and grid automation deployments," *CIRED-Open Access Proc. J.*, vol. 2017, no. 1, pp. 78–82, Oct. 2017.
- [60] S. Bavarian, L. Lampe, C. Siew, S. Lancashire, and K. Adeleye, "Leveraging the smart metering infrastructure in distribution automation," in *Proc. IEEE 3rd Int. Conf. Smart Grid Commun. (SmartGridComm)*, Nov. 2012, pp. 157–162.
- [61] *DC Systems, Energy Conversion & Storage*. Accessed: Mar. 29, 2019. [Online]. Available: <http://www.futureofcharging.com/presentations/7-bauer-tud.pdf>
- [62] R. Rodríguez-Sánchez, C. Medina, and E. Zabala, "Assessment of ICT-based architectures for the integration of EVs in smart grids," EEVC, Tech. Rep., 2015. [Online]. Available: [https://www.researchgate.net/publication/302954005\\_Assessment\\_of ICT-based Architectures\\_for\\_the\\_integration\\_of\\_EVs\\_in\\_Smart\\_Grids](https://www.researchgate.net/publication/302954005_Assessment_of ICT-based Architectures_for_the_integration_of_EVs_in_Smart_Grids)
- [63] *Design Guide for the Combined Charging System*. Accessed: Mar. 29, 2019. [Online]. Available: <https://www.charinev.org/ccs-at-a-glance/design-guide-for-ccs/>
- [64] *IONITY*. Accessed: Mar. 29, 2019. [Online]. Available: <https://ionity.eu/en/where-and-how.html>
- [65] *Enel X*. Accessed: Mar. 29, 2019. [Online]. Available: <https://www.enelx.com/en/e-mobility-app>
- [66] *Tesla*. Accessed: Mar. 29, 2019. [Online]. Available: [https://www.tesla.com/es\\_ES/findus#/bounds/65,55,34,-11?search=supercharger](https://www.tesla.com/es_ES/findus#/bounds/65,55,34,-11?search=supercharger)
- [67] *The Relationship Between Smart Grids and Smart Cities*. Accessed: Mar. 29, 2019. [Online]. Available: <http://resourcecenter.smartgrid.ieee.org/sg/product/publications/SGNL0115>
- [68] "The smart city opportunity for utilities," Scottmadden Manage. Consultants, Atlanta, GA, USA, Tech. Rep., 2017. [Online]. Available: <https://www.scottmadden.com/insight/the-smart-city-opportunity-for-utilities/>
- [69] *Standards and the Smart City* IEEE Standards, 2015. [Online]. Available: <https://smartgrid.ieee.org/resources/news/standards-and-the-smart-city>
- [70] A. Garrido-Marijuan, Y. Pargova, and C. Wilson, "The making of a smart city: Best practices across Europe," Eur. Commission, Brussels, Belgium, Tech. Rep., 2017. [Online]. Available: [https://smartcities-infosystem.eu/sites/default/files/document/the\\_making\\_of\\_a\\_smart\\_city\\_-\\_best\\_practices\\_across\\_europe.pdf](https://smartcities-infosystem.eu/sites/default/files/document/the_making_of_a_smart_city_-_best_practices_across_europe.pdf)
- [71] *Lighting PLC Applications*. Accessed: Mar. 29, 2019. [Online]. Available: <https://www.smart-energy.com/regional-news/europe-uk/street-lighting-problems-and-solutions/>
- [72] L. Calderoni, D. Maio, and S. Rovis, "Deploying a network of smart cameras for traffic monitoring on a 'city kernel,'" *Expert Syst. Appl.*, vol. 41, no. 2, pp. 502–507, 2014.

- [73] R. Martínez-Rodríguez-Osorio, M. Calvo-Ramon, M. Á. Fernández-Otero, and L. C. Navarrete, "Smart control system for LEDs traffic-lights based on PLC," in *Proc. 6th WSEAS Int. Conf. Power Syst.*, Lisbon, Portugal, 2006, pp. 256–260.
- [74] A. Sendin and I. Berganza, "Powerline communication is ready for the smart grid today," *Smart Metering Smart Energy Int.*, vol. 5, Jun. 2016. [Online]. Available: <https://www.engerati.com/article/power-line-communication-ready-smart-grid-today>
- [75] *IEEE Recommended Practice for Monitoring Electric Power Quality*, IEEE Standard 1159-2009, Jun. 2009.
- [76] D. Hong, J. Lee, and J. Choi, "Power quality monitoring system using power line communication," in *Proc. 5th Int. Conf. Inf. Commun. Signal Process.*, Dec. 2005, pp. 931–935.
- [77] M. M. Albu, M. Sănduleac, and C. Stănescu, "Syncretic use of smart meters for power quality monitoring in emerging networks," *IEEE Trans. Smart Grid*, vol. 8, no. 1, pp. 485–492, Jan. 2017.
- [78] *NIST Framework and Roadmap for Smart Grid Interoperability Standard, Release 1.0*, Standard 1108, Office Nat. Coordinator Smart Grid Interoperability, 2010.
- [79] P. Pakonen, M. Pikkarainen, B. Siddiqui, and P. Verho, "Electromagnetic compatibility between electronic loads and automated meter reading systems using PLC," in *Proc. 22nd Int. Conf. Exhib. Electr. Distrib.*, Jun. 2013, pp. 1–4.
- [80] P. Pakonen, S. Vehmasvaara, M. Pikkarainen, B. A. Siddiqui, and P. Verho, "Experiences on narrowband powerline communication of automated meter reading systems in finland," in *Proc. Electr. Power Qual. Supply Rel.*, Jun. 2012, pp. 1–6.
- [81] J. Matanza, S. Kiliccote, S. Alexandres, and C. Rodríguez-Morcillo, "Simulation of low-voltage narrow-band power line communication networks to propagate OpenAD signals," *J. Commun. Netw.*, vol. 17, no. 6, pp. 656–664, Dec. 2015.
- [82] S. Hong, "Harmonics and noise in photovoltaic (PV) inverter and the mitigation strategies," Solectria Renewables, Lawrence, MA, USA, Tech. Rep., 2010.
- [83] M. Gotz, M. Rapp, and K. Dostert, "Power line channel characteristics and their effect on communication system design," *IEEE Commun. Mag.*, vol. 42, no. 4, pp. 78–86, Apr. 2004.
- [84] S. K. Rönnerberg, M. H. J. Bollen, H. Amaris, G. W. Chang, I. Y. H. Gu, E. H. Kocewiak, J. Meyer, M. Olofsson, P. F. Ribeiro, and J. Desmet, "On waveform distortion in the frequency range of 2 kHz–150 kHz—Review and research challenges," *Electr. Power Syst. Res.*, vol. 150, pp. 1–10, Sep. 2017.
- [85] G. F. Bartak and A. Abart, "EMI of emissions in the frequency range 2 kHz–150 kHz," in *Proc. 22nd Int. Conf. Exhib. Electr. Distrib.*, Jun. 2013, pp. 1–4.
- [86] S. Rönnerberg, "Emission and interaction from domestic installations in the low voltage electricity network, up to 150 kHz," Ph.D. dissertation, Luleå Tekniska Univ., Luleå, Sweden, 2013.
- [87] E. O. A. Larsson and M. H. J. Bollen, "Measurement result from 1 to 48 fluorescent lamps in the frequency range 2 to 150 kHz," in *Proc. 14th Int. Conf. Harmon. Qual. Power (ICHQP)*, Sep. 2010, pp. 1–8.
- [88] A. Larsson, "On high-frequency distortion in low-voltage power systems," Ph.D. dissertation, Luleå Tekniska Univ., Luleå, Sweden, 2011.
- [89] S. K. Rönnerberg and M. H. J. Bollen, "Emission from four types of led lamps at frequencies up to 150 kHz," in *Proc. IEEE 15th Int. Conf. Harmon. Qual. Power*, Jun. 2012, pp. 451–456.
- [90] S. Rönnerberg, M. Bollen, and A. Gil-de-Castro, "Harmonic distortion from energy-efficient equipment and production in the low-voltage network," Tech. Rep., 2014. [Online]. Available: <https://www.diva-portal.org/smash/get/diva2:996504/FULLTEXT01.pdf>
- [91] A. Nejadpak, A. Sarikhani, and O. A. Mohammed, "Analysis of radiated EMI and noise propagation in three-phase inverter system operating under different switching patterns," *IEEE Trans. Magn.*, vol. 49, no. 5, pp. 2213–2216, May 2013.
- [92] I. Fernandez and N. Uribe-Pérez, I. Eizmendi, I. Angulo, D. de la Vega, A. Arrinda, and T. Arzuaga, "Characterization of non-intentional emissions from distributed energy resources up to 500 kHz: A case study in Spain," *Int. J. Elect. Power Energy Syst.*, vol. 105, pp. 549–563, Feb. 2019.
- [93] M. A. Sonmez, M. A. Zehir, M. Bagriyanik, and O. Nak, "Impulsive noise survey on power line communication networks up to 125 kHz for smart metering infrastructure in systems with solar inverters in turkey," in *Proc. Int. Conf. Renew. Energy Res. Appl. (ICRERA)*, Oct. 2013, pp. 705–710.
- [94] S. Schöttke, J. Meyer, P. Schegner, and S. Bachmann, "Emission in the frequency range of 2 kHz to 150 kHz caused by electrical vehicle charging," in *Proc. Int. Symp. Electromagn. Compat.*, Sep. 2014, pp. 620–625.
- [95] V. Cuk, "Power quality and EMC issues with future electricity networks," Joint Working Group C4.24/CIREC, Tech. Brochures, 2018, vol. 719. [Online]. Available: <https://research.tue.nl/en/publications/power-quality-and-emc-issues-with-future-electricity-networks>
- [96] M. H. J. Bollen, S. Rönnerberg, and F. Zavoda, "CIGRE/CIREC C4.24—power quality in the future grid—first introduction," in *Proc. Great Lakes Symp. Smart Grids*, 2014, pp. 1–5.
- [97] M. Bollen, M. Olofsson, A. Larsson, S. Rönnerberg, and M. Lundmark, "Standards for supraharmonics (2 to 150 kHz)," *IEEE Electromagn. Compat. Mag.*, vol. 3, no. 1, pp. 114–119, 1st Quart., 2014.
- [98] E. O. A. Larsson and M. H. J. Bollen, "Emission and immunity of equipment in the frequency range 2 to 150 kHz," in *Proc. IEEE Bucharest PowerTech*, Jun./Jul. 2009, pp. 1–5.
- [99] *Standardization in the Field of Electromagnetic Compatibility With Regard to Low Frequency Phenomena*, Standard IEC SC 77, 2019.
- [100] *EN IEC 55015:2019. Limits and Methods of Measurement of Radio Disturbance Characteristics of Electrical Lighting and Similar Equipment*, CENELEC, Brussels, Belgium, 2019.
- [101] *EN 55011:2016. Industrial, Scientific and Medical (ISM) Radio-Frequency Equipment—Electromagnetic Disturbance Characteristics—Limits and Methods of Measurement*, CENELEC, Brussels, Belgium, 2006.
- [102] *Electromagnetic Compatibility (EMC)—Part 2–5: Environment-Description and Classification of Electromagnetic Environments*, document IEC TR 61000-2-5.
- [103] *Voltage Characteristics of Electricity Supplied by Public Distribution Systems*, Standard En 50160, CENELEC, Brussels, Belgium, 2005.
- [104] *Specification for Radio Disturbance and Immunity Measuring Apparatus and Methods—Part 1-1: Radio Disturbance and Immunity Measuring Apparatus—Measuring Apparatus*, Standard CISPR 16-1-1:2015, International Electrotechnical Commission, 2010.
- [105] *Specification for Radio Disturbance and Immunity Measuring Apparatus and Methods. Part 2: Methods of Measurement of Disturbances and Immunity. Conducted Disturbance Measurements*, Standard CISPR 16-2-1, International Electrotechnical Commission, 2010.
- [106] *Specification for Radio Disturbance and Immunity Measuring Apparatus and Methods. Part 2: Methods of Measurement of Disturbances and Immunity. Measurement of Disturbance Power*, Standard CISPR 16-2-2, International Electrotechnical Commission, 2010.
- [107] *Guide for Identifying and Improving Power Quality in Power Systems*, IEEE Standard 1250-2011, 2011. [Online]. Available: <https://ieeexplore.ieee.org/document/5744556>
- [108] *On the Aim and Scope of TC7—Document for the TC 7 Inaugural Annual Meeting*, IEEE Standard, IEEE EMC Society Agenda Report, 2012. [Online]. Available: <https://www.emcs.org/assets/documents/On%20the%20Aim%20and%20Scope%20of%20TC%207.pdf>
- [109] L. Lampe and A. J. H. Vinck, "On cooperative coding for narrow band PLC networks," *AEU-Int. J. Electron. Commun.*, vol. 65, no. 8, pp. 681–687, Aug. 2011.
- [110] J. Bilbao, P. M. Crespo, I. Armendariz, and M. Médard, "Network coding in the link layer for reliable narrowband powerline communications," *IEEE J. Sel. Areas Commun.*, vol. 34, no. 7, pp. 1965–1977, Jul. 2016.
- [111] F. Versolatto and A. M. Tonello, "An MTL theory approach for the simulation of MIMO power-line communication channels," *IEEE Trans. Power Del.*, vol. 26, no. 3, pp. 1710–1717, Jul. 2011.
- [112] A. R. Metke and R. L. Ekl, "Security technology for smart grid networks," *IEEE Trans. Smart Grid*, vol. 1, no. 1, pp. 99–107, Jun. 2010.
- [113] R. Q. Hu, Y. Qian, H. H. Chen, and H. T. Mouftah, "Cyber security for smart grid communications: Part II [Guest Editorial]," *IEEE Commun. Mag.*, vol. 51, no. 1, pp. 16–17, Jan. 2013.
- [114] Y. Yan, Y. Qian, H. Sharif, and D. Tipper, "A survey on cyber security for smart grid communications," *IEEE Commun. Surveys Tuts.*, vol. 14, no. 4, pp. 998–1010, 4th Quart., 2012.
- [115] J. Liu, Y. Xiao, S. Li, W. Liang, and C. L. P. Chen, "Cyber security and privacy issues in smart grids," *IEEE Commun. Surveys Tuts.*, vol. 14, no. 4, pp. 981–997, 4th Quart., 2012.
- [116] R. Anderson and S. Fuloria, "Who controls the off switch?" in *Proc. 1st IEEE Int. Conf. Smart Grid Commun.*, Oct. 2010, pp. 96–101.
- [117] *Malta Smart Meter Hacking*. Accessed: Mar. 29, 2019. [Online]. Available: <https://www.maltatoday.com.mt/news/national/35650/enmalta-employees-suspended-over-1-000-tampered-smart-meters-20140211#.XJg46ihKg2w>
- [118] *Puerto Rico Smart Meter Hacking*. Accessed: Mar. 29, 2019. [Online]. Available: <https://krebsonsecurity.com/2012/04/fbi-smart-meter-hacks-likely-to-spread/>

- [119] A. G. Illera and J. V. Vidal, "Lights off! The darkness of the smart meters," in *Proc. BlackHat Eur.*, 2015. [Online]. Available: [https://www.youtube.com/watch?v=Z\\_y\\_vjYtAWM](https://www.youtube.com/watch?v=Z_y_vjYtAWM)
- [120] P. Jovanovic and S. Neves, "Dumb crypto in smart grids: Practical cryptanalysis of the open smart grid protocol," in *Proc. IACR Cryptol. ePrint Arch.*, 2015, p. 428.
- [121] L. Ji and Y. Jian, "The risk from power lines: How to sniff the G3 and prime data and detect the interfere attack," in *Proc. BlackHat*, 2016.
- [122] S. G. Hoffmann, "Layer-2 security for PLC—A comparison between ITU-T G.9903 and IEEE 1901.2," in *Proc. Int. Symp. Power Line Commun. Appl. (ISPLC)*, Mar. 2016, pp. 173–178.
- [123] M. S. Simó, G. L. López, and J. I. M. Novella, "Cybersecurity vulnerability analysis of the PLC PRIME standard," *Secur. Commun. Netw.*, vol. 2017, Jul. 2017, Art. no. 7369684.
- [124] I. Benitez, V. Gavara, and A. Quijano, "Evaluation of cybersecurity risks and vulnerabilities of advanced metering infrastructure components," in *Proc. CIGRE Colloq.*, 2017.
- [125] N. Luring, D. Szameitat, S. Hoffmann, and G. Bumiller, "Analysis of security features in DLMS/COSEM: Vulnerabilities and countermeasures," in *Proc. IEEE Power Energy Soc. Innov. Smart Grid Technol. Conf. (ISGT)*, Feb. 2018, pp. 1–5.
- [126] F. Passerini and A. M. Tonello, "Physical layer key generation for secure power line communications," 2018, *arXiv:1809.09439*. [Online]. Available: <https://arxiv.org/abs/1809.09439>
- [127] W. Fan, Z. Du, D. Fernández, and V. A. Villagrà, "Enabling an anatomic view to investigate honeypot systems: A survey," *IEEE Syst. J.*, vol. 12, no. 4, pp. 3906–3919, Dec. 2018.
- [128] T. Luo, Z. Xu, X. Jin, Y. Jia, and X. Ouyang, "IoT CandyJar: Towards an intelligent-interaction honeypot for IoT devices," in *Proc. Black Hat*, 2017, pp. 1–11.
- [129] S. Axelsson, "Intrusion detection systems: A survey and taxonomy," *Tech. Rep.*, 2000. [Online]. Available: [http://neuro.bstu.by/ai/To-dom/My\\_research/Paper-0-again/For-research/D-mining/Anomaly-D/Intrusion-detection/taxonomy.pdf](http://neuro.bstu.by/ai/To-dom/My_research/Paper-0-again/For-research/D-mining/Anomaly-D/Intrusion-detection/taxonomy.pdf)
- [130] J. Jow, Y. Xiao, and W. Han, "A survey of intrusion detection systems in smart grid," *Int. J. Sensor Netw.*, vol. 23, no. 3, pp. 170–186, 2017.
- [131] J. R. C. Nurse, S. Creese, and D. De Roure, "Security risk assessment in Internet of Things systems," *IT Prof.*, vol. 19, no. 5, pp. 20–26, 2017.
- [132] N. Uribe-Pérez, I. Angulo, D. de la Vega, A. Arrinda, T. Arzuaga, L. Marrón, S. Martínez, A. Sendín, and I. Urrutia, "TCP/IP capabilities over NB-PLC for Smart Grid applications: Field validation," in *Proc. IEEE Int. Symp. Power Line Commun. Appl. (ISPLC)*, Apr. 2017, pp. 1–5.
- [133] N. Uribe-Pérez, I. Angulo, D. de la Vega, T. Arzuaga, A. Arrinda, and I. Fernández, "On-field evaluation of the performance of IP-based data transmission over narrowband PLC for smart grid applications," *Int. J. Elect. Power Energy Syst.*, vol. 100, pp. 350–364, Sep. 2018.
- [134] J. A. Corchado, E. Manero, J. A. Cortés, A. Sanz, and L. Díez, "Application-layer performance analysis of prime in smart metering networks," in *Proc. IEEE Int. Conf. Smart Grid Commun. (SmartGridComm)*, Nov. 2016, pp. 332–337.
- [135] M. Seijo, G. López, J. I. Moreno, J. Matanza, S. Alexandres, C. Rodríguez-Morcillo, and F. Martín, "Let there be light: Dissecting how PRIME networks work based on actual traffic traces," in *Proc. IEEE Int. Conf. Smart Grid Commun. (SmartGridComm)*, Nov. 2015, pp. 472–477.
- [136] A. Sendín, I. Urrutia, M. Garai, T. Arzuaga, and N. Uribe, "Narrowband PLC for LV smart grid services, beyond smart metering," in *Proc. 18th IEEE Int. Symp. Power Line Commun. Appl.*, Mar./Apr. 2014, pp. 168–172.
- [137] I. Arechalde, M. Castro, I. García-Borreguero, A. Sendín, I. Urrutia, and A. Fernandez, "Performance of plc communications in frequency bands from 150 kHz to 500 kHz," in *Proc. IEEE Int. Symp. Power Line Commun. Appl. (ISPLC)*, Apr. 2017, pp. 1–5.
- [138] A. Sendín, I. H. Kim, S. Bois, A. Munoz, and A. Llano, "PRIME v1.4 evolution: A future proof of reality beyond metering," in *Proc. IEEE Int. Conf. Smart Grid Commun. (SmartGridComm)*, Nov. 2014, pp. 332–337.
- [139] F. Marcuzzi and A. M. Tonello, "Radio access network backhauling using power line communications," in *Broadband Communications Networks: Recent Advances and Lessons From Practice*. London, U.K.: InTechOpen, 2018.
- [140] *SENSIBLE Project*. Accessed: Mar. 29, 2019. [Online]. Available: <https://www.projectsensible.eu/cite>
- [141] *Iberdrola CAMPUS*. Accessed: Mar. 29, 2019. [Online]. Available: <https://www.iberdrola.com/people-talent/iberdrola-campus>
- [142] I. Arechalde, M. Castro, and I. García-Borreguero, "Solution for the detection of the source of noises that disturb the PLC communications," in *Proc. IEEE Int. Symp. Power Line Commun. Appl. (ISPLC)*, 2007, pp. 3–5. [Online]. Available: <http://isplc2017.ieee-isplc.org/files/2017/02/OK-PROGRAM.pdf>
- [143] K. M. Rabie and E. Alsusae, "On improving communication robustness in PLC systems for more reliable smart grid applications," *IEEE Trans. Smart Grid*, vol. 6, no. 6, pp. 2746–2756, Nov. 2015.
- [144] Y. Kim, J. N. Bae, and J. Y. Kim, "Performance of power line communication systems with noise reduction scheme for smart grid applications," *IEEE Trans. Consum. Electron.*, vol. 57, no. 1, pp. 46–52, Feb. 2011.
- [145] M. Korki, N. Hosseinzadeh, and T. Moazzeni, "Performance evaluation of a narrowband power line communication for smart grid with noise reduction technique," *IEEE Trans. Consum. Electron.*, vol. 57, no. 4, pp. 1598–1606, Nov. 2011.
- [146] L. Lampe, "Bursty impulse noise detection by compressed sensing," in *Proc. IEEE Int. Symp. Power Line Commun. Appl.*, Apr. 2011, pp. 29–34.
- [147] A. Mehboob, L. Zhang, and J. Khangosstar, "Adaptive impulsive noise mitigation using multi mode compressive sensing for powerline communications," in *Proc. IEEE Int. Symp. Power Line Commun. Appl.*, Mar. 2012, pp. 368–373.
- [148] J. Matanza, S. Alexandres, and C. Rodríguez-Morcillo, "Difference sets-based compressive sensing as denoising method for narrow-band power line communications," *IET Commun.*, vol. 7, no. 15, pp. 1580–1586, Oct. 2013.
- [149] A. Sendín, A. Llano, A. Arzuaga, and I. Berganza, "Field techniques to overcome aggressive noise situations in PLC networks," in *Proc. IEEE Int. Symp. Power Line Commun. Appl.*, Apr. 2011, pp. 113–117.
- [150] S. Akhshabi and C. Dovrolis, "The evolution of layered protocol stacks leads to an hourglass-shaped architecture," *ACM SIGCOMM Comput. Commun. Rev.*, vol. 41, no. 4, pp. 206–217, Aug. 2011.
- [151] F. Baker and D. Meyer, *Internet Protocols for the Smart Grid*, document RFC6272, 2011. [Online]. Available: <https://tools.ietf.org/html/rfc6272>
- [152] *Signalling on Low-Voltage Electrical Installations in the Frequency Range 3 kHz to 148,5 kHz. Part 1: General Requirements, Frequency Bands and Electromagnetic Disturbances*, Standard CENELEC EN50065, 2011.
- [153] A. Sanz, P. J. Pinero, J. M. Idiago, S. Esteban, and J. I. Garcia, "Narrowband power line communications evaluation in complex distribution networks," in *Proc. IEEE Int. Conf. Smart Grid Commun. (SmartGridComm)*, Nov. 2014, pp. 266–271.
- [154] G. Prasad, L. Lampe, and S. Shekhar, "In-band full duplex broadband power line communications," *IEEE Trans. Commun.*, vol. 64, no. 9, pp. 3915–3931, Sep. 2016.
- [155] F. Passerini and A. M. Tonello, "In band full duplex PLC: The role of the hybrid coupler," in *Proc. Int. Symp. Power Line Commun. Appl. (ISPLC)*, Mar. 2016, pp. 52–57.
- [156] G. Prasad and L. Lampe, "Full-duplex spectrum sensing in broadband power line communications," in *Proc. IEEE Int. Symp. Power Line Commun. Appl. (ISPLC)*, Apr. 2017, pp. 1–6.
- [157] G. Prasad, L. Lampe, and S. Shekhar, "Digitally controlled analog cancellation for full duplex broadband power line communications," *IEEE Trans. Commun.*, vol. 65, no. 10, pp. 4419–4432, Oct. 2017.
- [158] J. E. S. de Haan, P. H. Nguyen, W. L. Kling, and P. F. Ribeiro, "Social interaction interface for performance analysis of smart grids," in *Proc. IEEE 1st Int. Workshop Smart Grid Modeling Simulation (SGMS)*, Oct. 2011, pp. 79–83.
- [159] R. Kuffel, J. Giesbrecht, T. Maguire, R. Wierckx, and P. McLaren, "RTDS—a fully digital power system simulator operating in real time," in *Proc. Int. Conf. Energy Manage. Power Del. (EMPD)*, vol. 2, Nov. 1995, pp. 498–503.
- [160] K. Mets, J. A. Ojea, and C. Develder, "Combining power and communication network simulation for cost-effective smart grid analysis," *IEEE Commun. Surveys Tuts.*, vol. 16, no. 3, pp. 1771–1796, 3rd Quart., 2014.
- [161] P. Palensky, A. A. V. D. Meer, C. D. Lopez, A. Joseph, and K. Pan, "Cosimulation of intelligent power systems: Fundamentals, software architecture, numerics, and coupling," *IEEE Ind. Electron. Mag.*, vol. 11, no. 1, pp. 34–50, Mar. 2017.
- [162] E. Weingartner, H. vom Lehn, and K. Wehrle, "A performance comparison of recent network simulators," in *Proc. IEEE Int. Conf. Commun.*, Jun. 2009, pp. 1–5.
- [163] F. Aalamifar, A. Schlögl, D. Harris, and L. Lampe, "Modelling power line communication using network simulator-3," in *Proc. IEEE Global Commun. Conf. (GLOBECOM)*, Dec. 2013, pp. 2969–2974.

- [164] A. Sanz, P. Piñero, D. Montoro, and J. I. Garcia, "High-accuracy distributed simulation environment for PRIME networks analysis and improvement," in *Proc. IEEE Int. Symp. Power Line Commun. Appl.*, Mar. 2012, pp. 108–113.
- [165] *SimPRIME Simulator*. Accessed: Mar. 29, 2019. [Online]. Available: <https://www.iit.comillas.edu/jmatanza/SimPRIME/>
- [166] J. Matanza, S. Alexandres, and C. Rodríguez-Morcillo, "Automatic meter-reading simulation through power line communication," in *Proc. IEEE 21st Int. Symp. Modeling, Anal. Simulation Comput. Telecommun. Syst.*, Aug. 2013, pp. 283–287.
- [167] J. Matanza, S. Alexandres, and C. Rodríguez-Morcillo, "Advanced metering infrastructure performance using European low-voltage power line communication networks," *IET Commun.*, vol. 8, no. 7, pp. 1041–1047, May 2014.
- [168] L. González-Sotres, C. Mateo, P. Frías, C. Rodríguez-Morcillo, and J. Matanza, "Replicability analysis of PLC PRIME networks for smart metering applications," *IEEE Trans. Smart Grid*, vol. 9, no. 2, pp. 827–835, Mar. 2018.
- [169] M. Seijo, G. López, J. Matanza, and J. I. Moreno, "Planning and performance challenges in power line communications networks for smart grids," *Int. J. Distrib. Sensor Netw.*, vol. 2016, p. 28, Mar. 2016.
- [170] J. M. Domingo, S. A. Fernandez, C. M. de Amarillas, G. L. Lopez, and J. I. Moreno, "Together or separately? Evaluating the content free period in PRIME using SimPRIME," in *Proc. IEEE Int. Conf. Smart Grid Commun. (SmartGridComm)*, Oct. 2017, pp. 308–313.
- [171] E. Alonso, J. Matanza, C. Rodríguez-Morcillo, and S. Alexandres, "A switch promotion algorithm for improving PRIME PLC network latency," in *Proc. 18th IEEE Int. Symp. Power Line Commun. Appl.*, Mar./Apr. 2014, pp. 278–283.
- [172] M. de la Concepción Mora de Amarillas, G. L. López, J. Matanza, "I choose you! But why?: Proposal and evaluation of policies to promote service nodes to switches in prime networks," in *Proc. 18th IEEE Int. Symp. Power Line Commun. Appl.*, Apr. 2019, pp. 1–6.
- [173] A. Gogic, A. Mahmutbegovic, D. Borovina, I. H. Çavdar, and N. Suljanovic, "Simulation of the narrow-band PLC system implementing prime standard," in *Proc. IEEE Int. Energy Conf. (ENERGYCON)*, May 2014, pp. 1520–1525.
- [174] J. Larrañaga, J. Legarda, I. Urrutia, and A. Sendin, "An experimentally validated PRIME subnetwork simulation model for utility applications," in *Proc. IEEE Int. Symp. Power Line Commun. Appl. (ISPLC)*, Mar./Apr. 2015, pp. 95–100.
- [175] L. Di Bert, S. D'Alessandro, and A. M. Tonello, "A G3-PLC simulator for access networks," in *Proc. 18th IEEE Int. Symp. Power Line Commun. Appl.*, Mar./Apr. 2014, pp. 99–104.
- [176] M. Seijo, G. López, J. I. Moreno, J. Matanza, S. Alexandres, and C. Rodríguez-Morcillo, "On-line evaluation and planning tool for medium voltage-broadband over power line cells," in *Proc. IEEE Int. Energy Conf. (ENERGYCON)*, Apr. 2016, pp. 1–6.
- [177] K. Hopkinson, X. Wang, R. Giovanini, J. Thorp, K. Birman, and D. Coury, "EPOCHS: A platform for agent-based electric power and communication simulation built from commercial off-the-shelf components," *IEEE Trans. Power Syst.*, vol. 21, no. 2, pp. 548–558, May 2006.
- [178] H. Lin, S. S. Veda, S. S. Shukla, L. Mili, and J. Thorp, "GECO: Global event-driven co-simulation framework for interconnected power system and communication network," *IEEE Trans. Smart Grid*, vol. 3, no. 3, pp. 1444–1456, Sep. 2012.
- [179] D. P. Chassin, K. Schneider, and C. Gerkensmeyer, "GridLAB-D: An open-source power systems modeling and simulation environment," in *Proc. IEEE/PES Transmiss. Distrib. Conf. Expo.*, Apr. 2008, pp. 1–5.
- [180] T. Blochwitz, M. Otter, J. Åkesson, M. Arnold, C. Clauss, H. Elmqvist, M. Friedrich, A. Junghanns, J. Mauss, D. Neumerkel, and H. Olsson, "Functional mockup interface 2.0: The standard for tool independent exchange of simulation models," in *Proc. 9th Int. MODELICA Conf.*, Sep. 2012, Munich, Germany: Linköping Univ. Electronic Press, 2012, pp. 173–184.
- [181] T. Blochwitz, M. Otter, M. Arnold, C. Bausch, H. Elmqvist, A. Junghanns, J. Mauß, M. Monteiro, T. Neidhold, D. Neumerkel, and H. Olsson, "The functional mockup interface for tool independent exchange of simulation models," in *Proc. 8th Int. Modelica Conf.*, Dresden, Germany: Linköping Univ. Electronic Press, 2011, pp. 105–114.

- [182] S. Symington, K. L. Morse, and K. Petty, *IEEE Standard for Modeling and Simulation (M&S) High Level Architecture (HLA)-Federate Interface Specification*, IEEE Standard 1516-2000, 2001. [Online]. Available: <https://www.mscoe.org/content/uploads/2017/12/IEEE-1516-2010.pdf>
- [183] *Functional Mock-up Interface for Model Exchange and Co-Simulation*. Accessed: Mar. 29, 2019. [Online]. Available: <https://www.fmi-standard.org/>



**GREGORIO LÓPEZ** (M'14) received the M.Sc. degree in telecommunication engineering and the Ph.D. degree from the Universidad Carlos III de Madrid, in 2008 and 2014, respectively. He was an Assistant Professor with the Universidad Politécnica de Madrid, from April 2017 to December 2018, and as a Research Assistant with the Universidad Carlos III de Madrid, from 2009 to 2016. He has been an Assistant Professor with the ICAI School of Engineering, Universidad Pontificia Comillas, since January 2019. He has participated in several Spanish and European Research and Development projects in the areas of next generation networks (NGN), wireless sensor networks (WSN), and the application of machine-to-machine (M2M) communications to e-health, and smart grids. As a result of his research activities, he holds the European patent and has authored and coauthored more than 20 papers published in top-tier conferences and journals. His current research interests include the optimization of M2M communications networks based on analysis and simulation, and cybersecurity and data analytics for the Internet of Things (IoT).



**JAVIER MATANZA** received the B.Sc. degree in telecommunication engineering technologies, the M.Sc. degree in telecommunication engineering, and the M.Sc. degree in smart grids from Comillas Pontifical University, the M.Sc. degree in telecommunication engineering from the Polytechnic University of Valencia, Valencia, Spain, in 2008, and the Ph.D. degree from Comillas Pontifical University, Madrid, Spain, in 2013. He is currently a Research Professional with the Institute for Research in technology and a Lecturer in linear systems, communication theory, advanced digital communications with Universidad Pontificia Comillas. His current interests include powerline communication technologies, signal processing, and communication network simulations.



**DAVID DE LA VEGA** (M'10) received the M.Sc. and Ph.D. degrees in telecommunication engineering from the University of the Basque Country (UPV/EHU), in 1996 and 2008, respectively. His research interests include the analysis of the signal propagation, and mainly, on the analysis of the effects of different types of interferences and disturbances on the quality of the data transmission. Within the area of smart grids, he researches on the characterization of the electrical grid as propagation medium for data transmission, and on the effects of noise and emissions on the Smart Grid communications. He has been a Principal Investigator of competitive research projects funded by European, national, and regional calls and by industry. The results of his work are published in 36 indexed papers, and part of them are included in reports of regulatory and standardization bodies.



**MARTA CASTRO** received the M.Sc. degree in telecommunication engineering from the University of the Basque Country (UPV), Bilbao, Spain. She is responsible of management of the Smart Meters and Smart Grids areas as a Smart Data & Protocol Manager with TECNALIA. Since 2011, TECNALIA is the first privately funded applied research and technological development centre in Spain and one of the leading such centres in Europe. Her professional experience has been centered

in smart grid products certification and standardization, which is involved primarily in the conformity assessment of products according to European and International Standards. As a result, she has developed a deep knowledge of the processes of standardization and how standards play a role in the development of new and innovative products. She has an extensive experience in designing specification and test books to design the system and define the requirements for the products. She is an Active Member of the PRIME Alliance Specification and Certification Task Forces. She is involved in DLMS UA association for standardization and Meters&More association.



**AMAIA ARRINDA** received the M.Sc. degree in telecommunication engineering from the University of the Basque Country (UPV/EHU), Spain, in 1993. In September 1993, she joined the Department of Electronics and Telecommunications, University of the Basque Country (UPV/EHU), where she is currently a Full Professor. In February 2001, she presented her Ph.D. thesis dealing with interferences between terrestrial analogue and digital TV transmissions. She has stayed at

ENST, Bretagne, and CNET, France, during one year, and at the Wireless Networks and Communications Research Centre, Brunel University, U.K., for four months. She has been involved for more than 15 years in research projects related to measurements for several purposes (human exposure, digital broadcasting, and radio noise). She has coauthored many journal and conference papers. Her current research interests include signal propagation, measurements and simulations in PLC systems, and wireless systems.



**JOSÉ IGNACIO MORENO** received the Ph.D. degree in telecommunication from the Universidad Politécnica de Madrid, in 1996. He is currently an Associate Professor with the Universidad Carlos III de Madrid (UC3M), in 1997. He received the accreditation for Full Professor position by the National Agency for Quality Assessment and Accreditation of Spain. Since 1992, he has been working in international research projects related with protocol design, protocol engineering, network management, advanced networks, and wireless system performance.

During the last 10 years, he has led national and European projects on ICT topics with special focus on Sensors & Smart Grid technologies. He has published more than 100 papers in the field of advanced communications in technical books, magazines, and conferences.



**ALBERTO SENDIN** received the M.Sc. degree in telecommunication engineering, the M.A. degree in management for business competitiveness, and the Ph.D. degree from the University of the Basque Country, Spain, in 1996, 2001, and 2013, respectively. Since 1998, he has been with Iberdrola, Spain (one of the biggest electricity utilities) transforming its telecommunication networks, where he is currently the Head of telecommunications. He is also a part-time Professor with the University of

Deusto, Spain, and also with the ICAI, Universidad Pontificia Comillas, Spain, with almost two decades teaching Telecommunications and Project Management. He has authored eight telecommunication books edited by McGraw-Hill, Artech House, and others. He has published tens of papers, and has contributed to three PLC books, references in the area *Power Line Communications: Theory and Applications for Narrowband and Broadband Communications Over Power Lines*; *Power Line Communications: Principles, Standards and Applications from Multimedia to Smart Grid* (2nd Ed.); and *Communication and Networking in Smart Grids*.

• • •