

Amplifier Stability in the Case of Non-Linear Inductive Loads

¹Azhagan Avr

¹Loyola – ICAM College of Engineering and Technology (Electronics and Communication Engineering), Loyola College, Nungambakam, Chennai, Tamil Nadu, 600034, India.

²Anto Nivin. M

²Loyola – ICAM College of Engineering and Technology (Electronics and Communication Engineering), Loyola College, Nungambakam, Chennai, Tamil Nadu, 600034, India.

³Godwin Sylvester

³Loyola – ICAM College of Engineering and Technology (Electronics and Communication Engineering), Loyola College, Nungambakam, Chennai, Tamil Nadu, 600034, India.

⁴Dr. Romano Giannetti

⁴Universidad Pontificia Comillas (Electronics, Automation and Communications),
Universidad Pontificia Comillas, 25 Alberto Aguilera, Madrid, 28015, Spain.

⁵Dr. S. Saraswathi Janaki

⁵Loyola – ICAM College of Engineering and Technology (Electronics and Communication Engineering), Loyola College, Nungambakam, Chennai, Tamil Nadu, 600034, India.

Abstract

A classical closed loop amplifier was constructed with a non-linear inductive load and a sinusoidal current was inputted into the system in order to observe a self-oscillation. When in an amplifier, the load is inductive and non-linear; there will be a non-linear inductance on the loop of the amplifier. This problem can generate high-frequency oscillations in the circuit. These oscillations occur during the non-linear portion of the B-H curve (i.e) after the linear portion and before saturation. The objective of the research is to identify the conditions which lead to such oscillations. This paper provides the reasons for oscillations caused by Negative impedance and Inductive load saturation.

Keywords: Negative Impedance, B-H curve, Non-Linearity, magnetic core saturation, Oscillations, Inductive Loads.

INTRODUCTION

The primary aim of the paper is to analyze the reason for oscillations caused due to the non-linear nature of the inductive load at saturation. The paper contains the history of the problem and the previous research done to analyze its reasons. The main importance of our research is to provide a solution for the problem which will result in high efficiency

output in case of all non-linear inductive loads. Thus by decreasing the oscillations the output becomes more stabilized, thereby the motor runs more smoothly and due to smooth functioning the life of non-linear loads, say a motor can be bettered compared to a vibrating motor. Our paper would be more influential in increasing the life of non-linear inductive loads. This paper concentrates on Amplifier Simulation, Amplifier construction, Output analysis and Stability analysis.

EXISTING CHALLENGES

Oscillations due to non-linear inductive loads can be observed in applications using DC motors, DC-DC Converters, robotic motor and so on [1] [2]. One of the systems where such behavior was observed is on a Horizontal Boring Mill machine that is excited by a DC motor. According to the manufacturer's specification, the speed regulation is 1:100 and the motor rotates at 30 to 3000 rotations per minute. The problem occurs when the motor rotates at a minimum rpm (around 30rpm), where the slide or the travelling movement of the axis is not smooth, despite the lubrication of all gears and chains. Henceforth the rotation of the DC motor is not smooth, even though all the electrical parameters are found to be normal and also if these parameters are varied (within

acceptable limits) the oscillations continue to exist. This vibrating rotation is mainly attributed to the resistance and inductance values.

BACKGROUND

Relative Permeability, $\mu_r = \mu / \mu_0$

$\mu_0 = 4\pi * 10^{-7}$ H/M (Free Space)

$L = \mu N^2 A / l$ 1

Magnetic Flux density, $\phi = LI$2

In case of non-linear cores, the relationship between B and H ($B = \mu H$) can be defined by the fact μ_r is not a constant but a function of magnetic field intensity (B). Since permeability (μ) varies, inductance (L) also varies, therefore

$v = d\phi / dt$3

$v = d(L.I) / dt$4

$v = L.d(i) / dt + I.d(L) / dt$5

While the first term of equation 5 is the classical impedance term and the second term of equation 5 is the one that represent a (differential) component in the voltage which is proportional to the current, so behaves like a resistance. This equivalent resistance effect is not bound to be positive, depending on the non-linearity at hand.

CAUSES OF OSCILLATION

SATURATION AND ITS EFFECTS:

When the magnetic core saturates, the inductance and impedances offered by the component decreases, thus causes the current to produce a spike or harmonics at the output [3] [4]. The point in a B-H curve gives the value of permeability at that point [5].

Referring to the Hysteresis curve at non-linear region where the magnetic core saturates, it induces high frequency harmonics across the inductive load [6]. At saturation, the impedance drops in a non-linear way, which results in spikes like current at the load [3] [4] [7]. Sudden variation in impedances also varies the inductance of the inductive load and produces harmonics in it. A paper titled "Specify Saturation Properties of Ferrite Cores to Prevent Field Failure" [8] mentions that, by introducing air gaps in the core results in shrinking of the hysteresis curve thereby increasing the requirement for more magnetizing Current to attain saturation [9]. Hence the non-linearity of the curve reduces and becomes more linear [10].

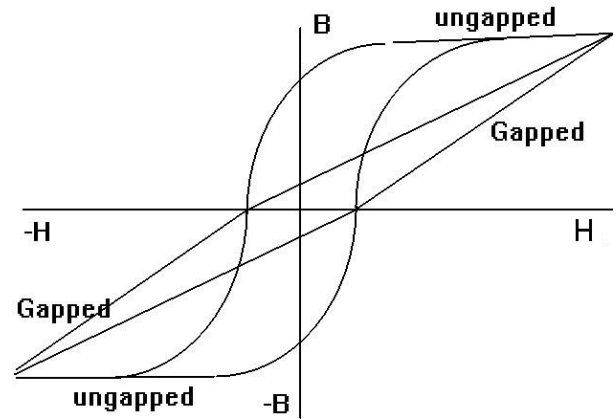

Figure 1: The above figure shows the difference between introducing and not introducing air gaps in the core [8].

NEGATIVE IMPEDANCE:

Negative resistance is an uncommon phenomenon that occurs in few non-linear electronic components [11]. Negative resistance can be found in Gunn diodes, Tunnel diodes, etc. As mentioned earlier the second term of equation 5, it is possible that a magnetic system, in presence of strong non-linearity, can exhibit negative differential resistance [12].

SOFTWARE & HARDWARE

The software tools used in our research are as follows, Quite Universal Circuit Simulator, Open choice by Tektronix and MS-Excel. QUCS as the name suggests we used it for circuit design and simulation. Open choice software was used to record the data of the waveform and also capture the waveform. It is software developed by Tektronix. The data recorded by open choice was stored in MS-Excel (.csv Format).

The hardware components used are LF411CN (comparator), TIP31C (NPN transistor), TIP32C (PNP transistor) and the Ferrite core (T60405-R6166-X016). The hardware tools used Digital Oscilloscope, Voltage source and Function generator.

EXECUTION DESIGN:

The circuit has been designed with three stages. The first stage has a comparator, the second stage has a power amplifier and the third stage is the non-linear inductive load [13]. The comparator compares the present incoming signal and the feedback signal from the output. The compared signal is amplified by the power amplifier stage and finally, it is given across the non-linear inductive load. After designing it was simulated using QUCS. The circuit and output are shown below:

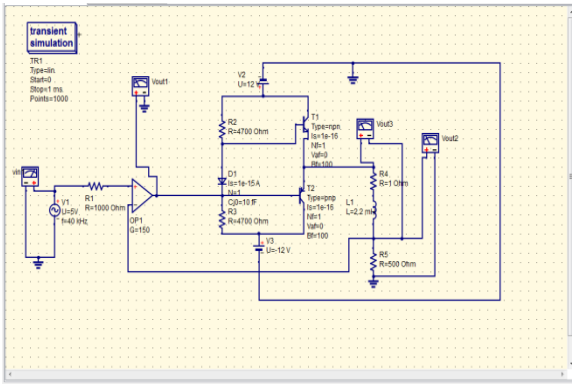

Figure 2: Circuit diagram in QUCS for simulation

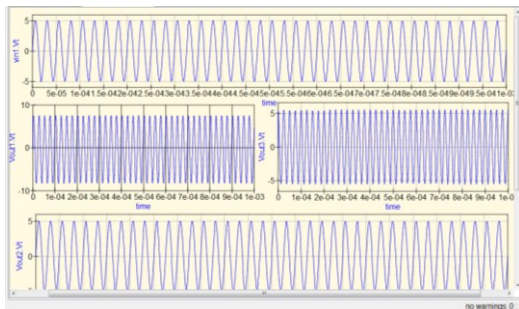

Figure 3: Simulated outputs

The output obtained by simulation does not contain any oscillations; but in practice, in some condition an oscillation at high frequency is observed.

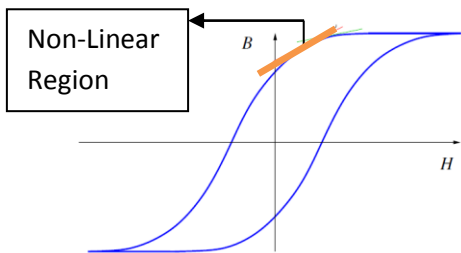

Figure 4: The figure shows the non-linear region of the B-H curve at saturation during which oscillations are produced at the output.

Then the circuit was put on a circuit board and output was observed and recorded.

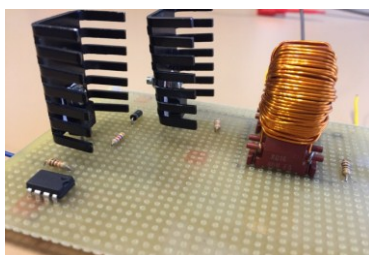

Figure 5: Side View of Circuit Components Mounted on a Circuit Board.

EVALUATION:

The circuit was built on board and a Digital oscilloscope was used to observe the oscillations. Both outputs from the primary and secondary (induced) coil were observed and were recorded using “Open Choice” software developed by Tektronix. The Data of the respected graphs were also recorded in .csv format for re-plotting the graphs and for future analysis. The output parameters were Voltage (V) and Current (I).

The oscillations observed were recorded for different amplitudes and different frequency values. Thus analyzing the recordings we are able to comment on the stability of the amplifier based on the oscillations across the non-linear inductive load for different input amplitudes and different input frequencies.

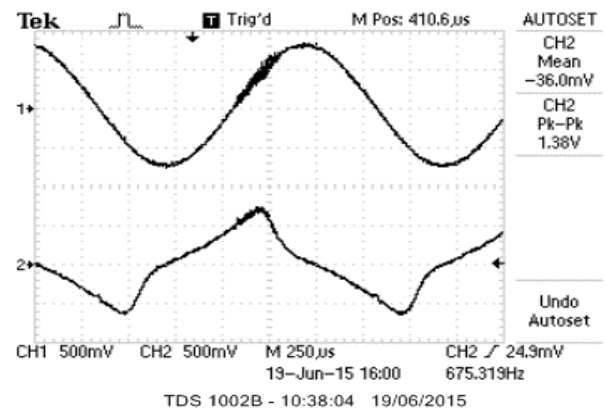

Figure 6: The graph above suggests that oscillations occur only at a certain part of the complete cycle.

Graphs shown below are the magnified view of oscillations.

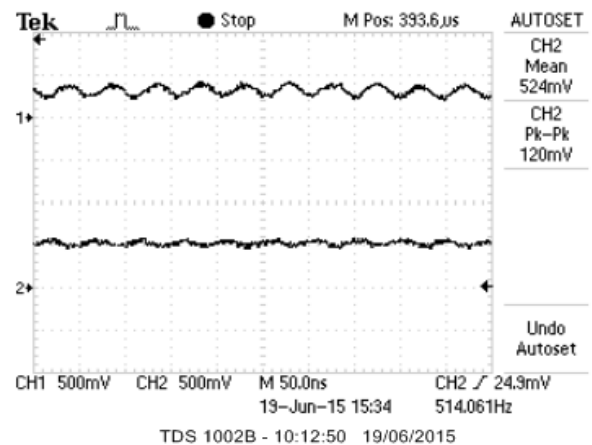

Figure 7: Oscillation in primary and secondary coil amp=0.5v; freq=514Hz

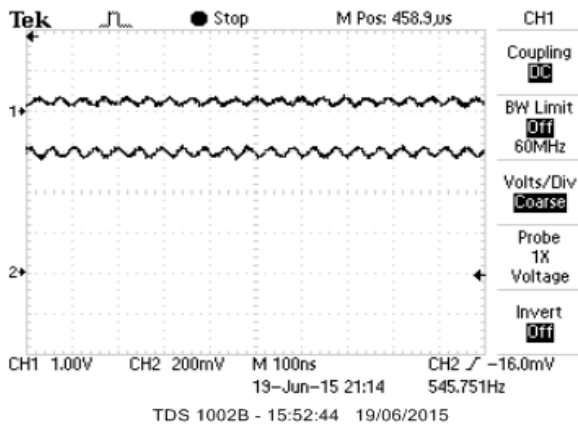

Figure 8: Oscillation in primary and secondary coil
 amp=0.65v; freq=546Hz

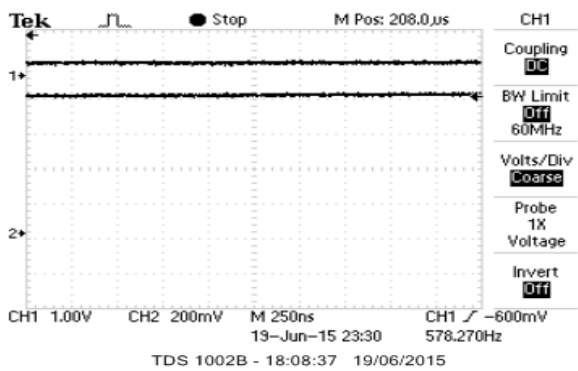

Figure 9: Oscillation in primary and secondary coil
 amp=0.77v; freq=578Hz

Reduced oscillations and stability can be better understood using the gain plot at various frequencies and at three different input amplitudes.

Table 2:

I/p	0.5v		0.65v		0.77v	
Hz	Osc Amp.V	Gain	Osc Amp.V	Gain	Osc Amp.V	Gain
50	0.001	-17.9	0.006	-19.61	0.006	-17.91
100	0.006	-29.9	0.006	-44.2	0.006	-12.72
150	0.006	-25	0.01	-8.8	0.004	-18.08
200	0.006	-26.4	0.01	-8.369	0.012	-11.20
256	0.026	-20.4	0.03	-4.04	0.016	-7.627
306	0.016	-3.45	0.05	-2.779	0.02	-5.183
360	0.04	-1.11	0.05	-1.938	0.02	-2.052
420	0.8	-0.07	0.056	-1.419	0.008	-3.821
460	0.1	1.289	0.07	-0.467	0.016	-1.938
514	0.12	1.289	0.04	-0.355	0.024	-0.778
624	0.1	2.923	0.01	-1.806	0.06	-0.828
676	0.1	3.638	0.03	-1.419	0.06	0.112
734	0.12	4.082	0.01	-0.244	0.04	1.160
994	0.12	4.082	0.02	2.865	0.04	3.997

EXPERIMENTAL RESULTS AND ANALYSIS

Based on the results obtained the oscillation report can be framed as follows:

Table 1:

INPUT AMPLITUDE	OSCILLATION OUTPUT (Frequency, Amplitude)
0.5V	(360Hz-1KHz, 0.08V-0.12V)
0.65V	(300Hz-460Hz, 0.05V-0.07V)
0.77V	(624Hz-676Hz, 0.06V)

Table 1 provides information on the frequency ranges at which oscillations exist (sampled range is 50Hz to 1KHz). The left column consists of input voltage values and the right column consists of the frequency range at which oscillations occur and the amplitude range of the oscillation.

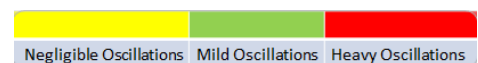

Table 2 shows the amplitude of oscillations at the output for particular frequencies of the given input amplitudes. Also the gain at that instance is also shown. We classify that; the oscillations are negligible if their amplitudes are in the range of 0.001V-0.009V, oscillations are considered to be mild if their amplitudes are in the range of 0.01V-0.04V and oscillation amplitude values greater than or equal to 0.05V tend to affect the stability of the output or the performance of the load. As shown in figure 4, during the non-linear region of the B-H curve during saturation, the current driven at the output is more and resulting in higher amplitudes of oscillations. The amplitudes of these oscillations are values above 0.05V. These values are highlighted in white cells in Table 2.

The plot below is based on the values given in Table 2:

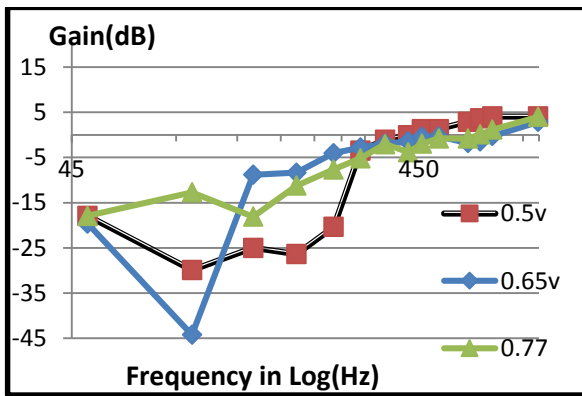

Figure 10: Plot between Gain and Frequency for different input signal amplitudes.

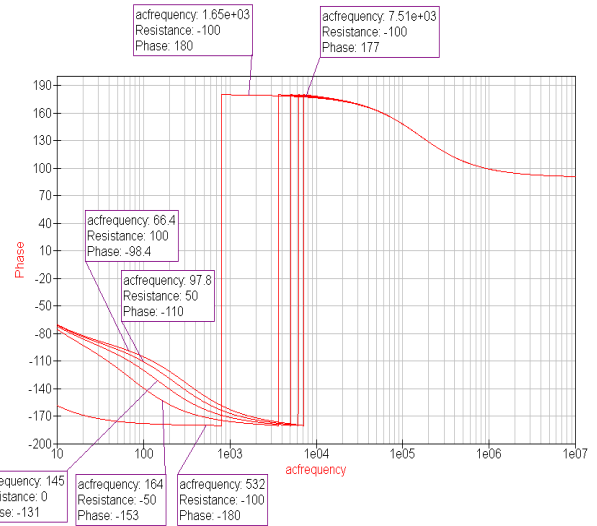

Figure 12: Negative resistance causing oscillation.

Hence from the Table 2 and the Fig10 we can understand that in order to amplify a signal we need gain, but gain increases only with positive feedback and positive feedback results in oscillations. Hence it is necessary to have a small gain so that we achieve amplification of the input signal.

Next we explain how negative resistance could play a role in causing oscillations across the non-linear inductive load. The figure 12 is an out system while driving in current consists of a main operational amplifier followed by a low pass filter and then a buffer amplifier (ideal op-amp). All parameters are chosen to be a representative of generic scenario, and the output is simulated for the open loop response (vfb). The resistance (R =Resistance) is simulated for 5 values of -100, -50, 0, 50, 100 ohm.

Fig 12 is the simulated output of phase Bode plot of the open loop response. The simulated output plot consists of various phase plots for various resistance values.

Given that the amplifier is a minimum phase system, with no positive zeros nor poles, we can use the Bode simplified method to assess stability, by checking that the open loop gain is less than 0dB when the phase crosses the critical value at 180 degrees. It can be seen that a negative differential resistance has the effect of shifting the critical point to the left, at lower frequencies, where the open loop amplitude gain is generally higher, basically due to the effect of the compensation of the operational amplifier. This phenomenon will thus have the effect of reducing stability margins (either phase or gain) and so it increases the risk of oscillations in the system.

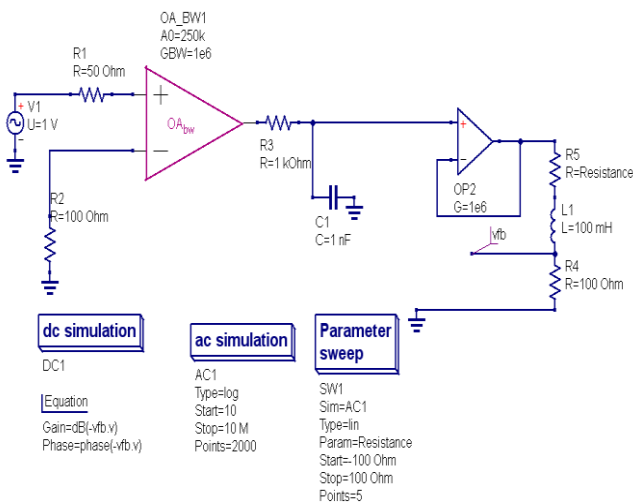

Figure 11: Simulated circuit for proving oscillations caused by negative resistance.

CONCLUSION

For analyzing the stability of amplifiers due to the non-linear nature of inductive loads we have tested, constructed and analyzed the output of the amplifier across the non-linear inductive loads and determine the reasons for oscillations across the loads. Now with this report one will be able to understand the reason for oscillation in a ferrite core caused by negative impedance and also during saturation. Hence its behavior under various frequencies and amplitudes are also studied and explained. The results of our work will help in finding solutions to problems faced by industries that use DC motors, DC-DC converters and so on. The challenge faced is the absence of a control mechanism [14] [15] [16], which cause excessive internal losses within non-linear inductive loads. Hence it is necessary to bring about the stability in an amplifier by reducing the oscillations.

REFERENCES

- [1] Kiseleva, M.A., Kuznetsov, N.V., Leonov, G.A., and Neittaanmaki, P. (2012), "Drilling systems failures and hidden oscillations", In IEEE 4th International Conference on Nonlinear Science and Complexity, NSC 2012 - Proceedings, 109{112.doi:10.1109/NSC.2012.6304736.
- [2] Andrievsky, B.R., Kuznetsov, N.V., Leonov, G.A., and Pogromsky, A.Y. (2013), "Hidden oscillations in aircraft flight control system with input saturation", IFAC Proceedings Volumes (IFAC-PapersOnline), 5(1), 75{79.doi:10.3182/20130703-3-FR-4039.00026.
- [3] Ismail Daut, Syafruddin Hasan, and Soib Taib, "Magnetizing Current, Harmonic Content and Power Factor as the Indicators of Transformer Core Saturation" Journal of Clean Energy Technologies, Vol. 1, No. 4, October 2013.
- [4] Yilu Liu and Zhenyuan Wang, - Virginia Tech "Modeling of Harmonic Sources and Magnetic Core Saturation", 1998, Citeseer,
- [5] Magnetic Core Characteristics, Texas Instruments, <http://www.ti.com/lit/ml/slup124/slup124.pdf>
- [6] A. H. A. Haj and I. E. Amin, "Factors that Influence Transformer No-Load Current Harmonics," IEEE Transaction on Power Delivery, vol. 15, no. 1, January 2000, pp. 163-166.
- [7] Bragin, V.O., Vagaitsev, V.I., Kuznetsov, N.V., and Leonov, G.A. (2011), "Algorithms for finding hidden oscillations in nonlinear systems", The Aizerman and Kalman conjectures and Chua's circuits. Journal of Computer and Systems Sciences International, 50(4), 511{543. doi: 10.1134/S106423071104006X.
- [8] George G. Orenchak, General Manager, TSC Ferrite International, "Specify Saturation Properties of Ferrite Cores to Prevent Field Failure".
- [9] Antônio Flavio Licarião Nogueira, Gabriel Grunitzki Facchinello & Leonardo Adriano Ramos, Santa Catarina State University, Joinville, Santa Catarina, Brazil, "Prediction of Magnetizing Currents in Power Transformers using Numerically Simulated Open-circuit Tests", Ijrras, Volume 17, Issue 2, November 2013.
- [10] Guanghao Liu, Xiao-Bang Xu, "Improved Modeling of the Nonlinear B-H Curve and Its Application in Power Cable Analysis", IEEE Transaction on Magnetics, vol. 38, No. 4, July 2002.
- [11] E. W. Herold, "Negative resistance and devices for obtaining it", Proceedings of Radio Engineers, Volume 23, Number 10, October, 1935.
- [12] F. Shoucair, EECS Department, UC Berkeley, Berkeley, CA 94720, shoucair@eecs.berkeley.edu, Ljiljana Trajkovic, School of Engineering Science, Simon Fraser University, Burnaby, BC, Canada, ljilja@cs.sfu.ca, "Analysis and simulation of simple transistor structures exhibiting negative differential resistance", November, 1999 researchgate.net.
- [13] C. W. T. McLyman, Transformer and Inductor Design Handbook, 3rd Edition, Revised and Expanded, Marcel Dekker. Inc., New York, 2004.
- [14] M. Ould Ahmedou, M. Ferfra, M. Chraygane and M. Maaroufi, "A New Modeling of the Non-Linear Inductances in MATLAB", A Fundamental Tool for Scientific Computing and Engineering Applications, Volume 1, Intech.
- [15] M.A. Kiseleva, N.V. Kuznetsov, G.A. Leonov, P. Neittaanmaki, "Hidden oscillations in drilling system actuated by induction motor", The International Federation of Automatic Control (IFAC), International Workshop on Periodic Control Systems, Caen, France. July 3-5, 2013.
- [16] M.A. Kiseleva, N.V., N.V. Kondratyeva, Kuznetsov, G.A. Leonov, E.P. Solovyeva, "Hidden periodic oscillations in drilling system driven by induction motor", The International Federation of Automatic Control (IFAC), Proceedings of the 19th World Congress, Cape Town, South Africa. August 24-29, 2014.